



Exablate Prime

Operator's Manual

For Exablate 4000 Type 1.1 Systems Running Software Version 9.01

Copyright ©2024 InSightec Ltd. (InSightec), all rights reserved.

Exablate 4000 Type 1.1 transcranial MR guided focused ultrasound ('Exablate Prime'), Software version 9.01, processing software, and its related documentation are the confidential proprietary property of InSightec. Only licensees of InSightec ('InSightec') have the right to use the information contained herein. Only licensees specifically granted copy and/or transfer rights have the right to copy and/or transfer this information. Any unauthorized use, disclosure, assignment, transfer or reproduction of this confidential information will be prosecuted to the full extent of the law.

InSightec shall not be liable nor obliged in any manner in respect to any bodily injury and/or property damage arising from the use of this software if such use is not in strict compliance with the instructions and safety precautions contained in the relevant operating manuals, including all supplements thereto, in all product labels and according to the terms of warranty and sale of this software, nor if any changes unauthorized by InSightec are made to the software contained herein.

User-provided programs or protocols are not validated nor warranted by InSightec. The use of data obtained with such user provided software or protocols are the sole responsibility of the user.

Users should be aware of the risk of transmission of computer viruses by exchanging files and CDs.

Trademarks of third party proprietors are the sole property of those proprietors.

Specifications are subject to change without notice and following applicable regulation and laws.

One or more parts of the product may incorporate or be distributed with open source software. Refer to the Copyright Notice button in the Utilities Screen.

InSightec website: <http://www.insightec.com>

This document is the property of InSightec Ltd., and contains proprietary and confidential information of InSightec Ltd. A nondisclosure agreement between the recipient and InSightec Ltd. has been executed prior to receipt of this document. This document is loaned on the express conditions that neither it nor the information contained therein shall be disclosed to others without the express consent of InSightec Ltd. In addition, the document shall be returned to InSightec Ltd. upon request with no copies made.

Contact information for equipment manufacturer and technical services:



InSightec, Ltd.
5 Nachum Heth St. PO Box 2059
Tirat Carmel 39120 Israel
www.insightec.com



Obelis s.a.
Bd. General Wahis 53,
1030 Brussels, Belgium

For Technical Support contact InSightec at +44-808-189-0427 or at Service_EMEA@insightec.com.

REVISION INFORMATION

Manual Catalog Number: **PUB41010050**

Revision Release Date: **November 2024**

This is the **Revision 1.0** release of the Exablate 4000 Operator's Manual for System Software Version 9.01, applicable for Mid-Frequency Exablate 4000 systems installed within 1.5 and 3.0 Tesla MRI Systems.

Each page of this manual has a revision level at the bottom. This indicates the release level for the individual chapters. Note that when the manual is updated, not all the chapters are necessarily updated, each chapter has its own revision level. The revision level designation for the manual is that which appears on the top of the second page of this manual). The following table provides a complete list of the revision information, by chapter, for this release of the operator's manual.



WARNING:

W107

Ensure that this document conforms to your installed Exablate product, system configuration and Workstation (WS) software (SW) version. To verify your installed Exablate WS SW version, see information in the Utilities screen.



NOTE:

N102

All pictures and illustrations in this document are provided as examples and for reference only.

CHAPTER #	CHAPTER NAME	CHAPTER REVISION, DATE
Chapter 1	SYSTEM OVERVIEW	1.0, 11/24
Chapter 2	SAFETY	1.0, 11/24
Chapter 3	GETTING STARTED	1.0, 11/24
Chapter 4	TOOLS & OVERLAYS	1.0, 11/24
Chapter 5	DAILY QUALITY ASSURANCE (DQA)	1.0, 11/24
Chapter 6	SCREENING (SDR Calculation)	1.0, 11/24
Chapter 7	PRE-PLANNING SESSION	1.0, 11/24
Chapter 8	TREATMENT: PLANNING STAGE	1.0, 11/24
Chapter 9	TREATMENT: THERAPY STAGE	1.0, 11/24
Chapter 10	SETTINGS	1.0, 11/24
Chapter 11	REPLAY MODE	1.0, 11/24
Chapter 12	CLEANING AND DISINFECTION PROCEDURE	1.0, 11/24
Chapter 13	DATA MANAGEMENT	1.0, 11/24
Appendix A	MANUAL DRAIN KIT USE INSTRUCTIONS	1.0, 11/24
Appendix B	HARD DRIVE REPLACEMENT	1.0, 11/24

TABLE OF CONTENTS

REVISION INFORMATION	III
TABLE OF CONTENTS	IV
LIST OF FIGURES	VI
1. SYSTEM OVERVIEW	12
1.1. INTRODUCTION	12
1.2. INTENDED USERS	12
1.3. DOCUMENT CONVENTIONS	13
1.4. SCOPE OF THIS MANUAL	20
1.5. SYSTEM CHARACTERISTICS	20
1.6. SYSTEM COMPONENTS	23
1.7. EXABLATE HEAD FRAME INSTRUCTIONS FOR USE	34
1.8. HEAD COIL SPECIFICATIONS	45
2. SAFETY	50
2.1. EXABLATE GENERAL SAFETY CONSIDERATIONS	50
2.2. OPERATOR AND PATIENT PRECAUTIONS	55
2.3. WATER SYSTEM PRECAUTIONS	61
2.4. HEAD COIL PRECAUTIONS	63
2.5. ELECTROMAGNETIC COMPATIBILITY (EMC) PRECAUTIONS	65
3. GETTING STARTED	69
3.1. SYSTEM SET-UP	69
3.2. REMOTE CONNECTION	75
3.3. PATIENT POSITIONING AND RELEASE	77
3.4. APPLICATION SELECTION MENU	84
3.5. OPERATING THE WATER SYSTEM	91
3.6. SHUTDOWN	101
4. TOOLS & OVERLAYS	103
4.1. TREATMENT SCREEN - OVERVIEW	103
4.2. TOOL BAR	114
4.3. IMAGE RETRIEVAL DIALOG	129
4.4. LOAD AND VISUALIZE TRACTOGRAPHY	130
5. DAILY QUALITY ASSURANCE (DQA)	132
5.1. DQA SET UP PROCEDURE	133
5.2. DQA SET UP HOLDER	134
5.3. HANDLING INSTRUCTIONS OF THE DQA PHANTOM GEL	136
5.4. DQA FLOW	137
6. SCREENING (SDR CALCULATION)	140
6.1. SCREENING SCREEN	140
6.2. SCREENING FLOW	142
7. PRE-PLANNING SESSION	144
7.1. OVERVIEW	144
7.2. PRE-OPERATIVE IMAGE GUIDELINES	145
7.3. PLANNING SESSION PROCEDURE – WITH PRE-OPERATIVE MR IMAGES	147

8. TREATMENT: PLANNING STAGE	150
8.1. OVERVIEW.....	150
8.2. LOADING PRE-OPERATIVE DATA.....	153
8.3. CALIBRATION SUBSTAGE.....	155
8.4. SCAN SUBSTAGE.....	159
8.5. NO PASS REGION (NPR) SUBSTAGE.....	168
8.6. REGISTRATION SUBSTAGE.....	173
8.7. AC-PC PLANE.....	177
8.8. TARGETING SUBSTAGE.....	180
8.9. MOVEMENT EVALUATION.....	187
9. TREATMENT: THERAPY STAGE	193
9.1. OVERVIEW.....	193
9.2. THERAPY STAGE WARNINGS AND CAUTIONS.....	203
9.3. TREATMENT FLOW AND APPROACH.....	205
9.4. THE DEFINE SUBSTAGE.....	210
9.5. THE SONICATE SUBSTAGE.....	225
9.6. THE REVIEW SUBSTAGE.....	232
10. SETTINGS	238
10.1. OVERVIEW.....	238
10.2. SYSTEM.....	239
10.3. PROFILE.....	243
10.4. ENTRANCE SCREEN LISTS.....	250
10.5. SYSTEM SETTINGS (TREATMENT MODE).....	253
11. REPLAY MODE	258
11.1. OVERVIEW.....	258
11.2. REPLAY TOOLBOX.....	259
11.3. ONLINE REPLAY.....	260
11.4. OFFLINE REPLAY.....	260
12. CLEANING AND DISINFECTION	262
12.1. CLEANING/DISINFECTION MATERIALS.....	262
12.2. PATIENT MEMBRANE AND COIL HANDLING PROCEDURE.....	263
12.3. EXABLATE MRI ADAPTER BASEPLATE, HS AND TABLE CLEANING PROCEDURE.....	263
12.4. TRANSDUCER HANDLING PROCEDURE.....	264
12.5. TRANSDUCER AND WATER SYSTEM DISINFECTION PROCEDURE.....	264
12.6. HEAD FRAME CLEANING PROCEDURE.....	271
13. DATA MANAGEMENT	275
13.1. DATABASE OVERVIEW.....	275
13.2. CYBER SECURITY.....	283
13.3. EXABLATE SYSTEM MINIMUM NETWORK REQUIREMENTS AND SECURITY CONFIGURATIONS.....	286
A. MANUAL DRAIN KIT USE INSTRUCTIONS	289
B. HARD DRIVE REPLACEMENT	291

LIST OF FIGURES

Figure 1-1: Schematic representation of system component layout on-site	24
Figure 1-2: Exablate Neuro Operator Console Workstation	25
Figure 1-3: Examples of Front End Unit configurations (For illustration only)	26
Figure 1-4: MRI Table Adapter Baseplate (for illustration purposes only)	27
Figure 1-5: Helmet System	27
Figure 1-6: Patient Stop Sonication Button.....	28
Figure 1-7: STC Cart Without (Left) and with (Right) Helmet System.....	29
Figure 1-8: Water System Control 'Home' Screen (L) and Chiller (R) (For illustration only).....	30
Figure 1-9: Exablate Neuro Equipment Cabinet (illustration).....	31
Figure 1-10: Head Frame Types.....	33
Figure 1-11 The Exablate Frame Set.....	35
Figure 1-12: Exablate Neuro Patient Fixation Kit (PFK).....	36
Figure 1-13: Exablate Caliper for Head diagonal measurement and combination estimation	37
Figure 1-14: Adapter Combinations	38
Figure 1-15: Connecting Side Holders to the Headframe (for illustration purposes only)	38
Figure 1-16: Head Frame Screws and Wrenches	39
Figure 1-17: Internal Adapter insertion to posts	39
Figure 1-18: UCHRA Frame Components	42
Figure 1-19: Examples of Tc MrgFUS Head Coil	45
Figure 1-20: Examples of Tc MRgFUS Head Coil Sockets (For illustration only)	45
Figure 1-21: Head Coil connector socket.	46
Figure 1-22: Coil Connector Plug connecting to the Coil Connector Socket (For illustration only).....	46
Figure 1-23: Examples of MR connectors	48
Figure 3-1: STC Bridge Coupled with MR Table for HS Transfer	71
Figure 3-2: Transferring the HS to the MR Table	72
Figure 3-3: Selecting 'Exablate' as External Host (GE MR Interface)	73
Figure 3-4: Remote Session Login Menu.....	75
Figure 3-5: Login Menu	76
Figure 3-6: Application Selection Menu - Remote Connection.....	76
Figure 3-7: Examples of Patient Membrane Positions.....	78
Figure 3-8: Examples of Patient Membrane dispositions according to Head Coil Socket Position.	78
Figure 3-9: Subject Positioned on MR table with Leg Holder (for illustration purposes only)	81
Figure 3-10: Mechanical Positioning Unit. Levers (Left), Locks (Right).....	82
Figure 3-11: A-P Positioner Lever	83
Figure 3-12: 1.5T TcMRgFUS Head Coil Connector Plug and Socket (For illustration only)	84
Figure 3-13: Select Application Screen (For illustration only).....	85
Figure 3-14: Main Screen	86

Figure 3-15: Treatment Mode Entrance Tab..... 87

Figure 3-16: Example of membrane code 89

Figure 3-17: Patient Membrane Code Area 89

Figure 3-18: Water System Remote Controller 91

Figure 3-19: Water System Remote Controller States:..... 92

Figure 3-20: Water System Operating Modes 93

Figure 3-21: Degas Mode Screens..... 95

Figure 3-22: Circulating Screens..... 96

Figure 3-23: Transducer positioning screen..... 96

Figure 3-24: Clean Mode Screen Sequence 97

Figure 3-25: Example of Leak Mitigation Clamp Usage..... 100

Figure 4-1: Treatment Stage Screens 103

Figure 4-2: Therapy Navigation Bar..... 106

Figure 4-3: Tooltip Image Information Example 107

Figure 4-4: Annotations on Image Viewer Window 110

Figure 4-5: Cursor Coordinates 112

Figure 4-6: Device and MR Status Bar 113

Figure 4-7: Tools Bar Structure 114

Figure 4-8: View Drop-Down Menu Structure 115

Figure 4-9: Transducer Elements Window 117

Figure 4-10: Measure Drop-Down Menu Structure 120

Figure 4-11: Overlays Drop-Down Menu Structure 122

Figure 4-12: Delete Drop-Down Menu Structure..... 124

Figure 4-13: Compare Drop-Down Menu Structure 125

Figure 4-14: Swipe tool's Sliders 126

Figure 4-15: Flicker 127

Figure 4-16: Image Retrieval Dialog Menu..... 129

Figure 4-17: Tractography visualization and Legend 131

Figure 5-1: Aligned Landmark Labels 133

Figure 5-2: DQA Set Up Holder Components. Phantom Gel Holder (A), Patient Membrane (B), Membrane Holder (C), Lock (D), – for illustration only 134

Figure 5-3: Mounting Jig..... 134

Figure 5-5: 3D break down of DQA Set Up Holder Assembly. DQA Phantom Gel (E), Phantom Gel Holder (A), Patient Membrane (B), Membrane Holder (C), Lock (D), – for illustration only..... 136

Figure 5-6: DQA Start-Up Screen..... 137

Figure 5-7: DQA Plan Follow-up 138

Figure 6-1: Screening Mode Screen 140

Figure 7-1: Planning Image Prescription Guides 146

Figure 7-2: Pre-Planning Entrance Screen..... 147

Figure 8-1: Planning Screen..... 150

Figure 8-2: Example of Planning Session Database Screen..... 154

Figure 8-3: Calibration Screen..... 156

Figure 8-4: Transducer Focal Coordinates 157

Figure 8-5: Detected MRI Frequency Frame 157

Figure 8-6: Scan Screen 159

Figure 8-7: Example of Scan Planning 161

Figure 8-8: Prescription guidelines for Sagittal scan: Through AC-PC and midline 166

Figure 8-9: NPR Review ToolBox 168

Figure 8-10: Registration Toolbox..... 173

Figure 8-11: AC-PC Plan Toolbox..... 177

Figure 8-12: Targeting Substage Toolbox..... 181

Figure 8-13: Target Coordinates Section..... 183

Figure 8-14: Manual Target Placement Tools 183

Figure 8-15: Patient Information..... 186

Figure 8-16: Movement Evaluation Screen..... 188

Figure 8-17: Movement Evaluation Toolbox..... 189

Figure 9-1: TREATMENT: THERAPY STAGE 193

Figure 9-2: Therapy Stage Navigation Bar..... 194

Figure 9-3: Sonication stage image window layout (Sagittal sonication) 195

Figure 9-4: Thermal Image Types..... 196

Figure 9-5: Thermal Image Controls..... 197

Figure 9-6: Temperature Graph 200

Figure 9-7: Temperature Graph Features 201

Figure 9-8: Define Substage Screen 210

Figure 9-9: Define Substage Toolbox Controls..... 211

Figure 9-10: Sonication Parameter Control 212

Figure 9-11: Define Substage Tools Tab..... 216

Figure 9-12: Sonication Preferences Tab 217

Figure 9-13: Advanced Sonication Preference Menu 218

Figure 9-14: Scan Preference Tab 220

Figure 9-15: Advanced Thermal Scan Preferences Menu..... 222

Figure 9-16: Sonicate Substage Toolbox..... 227

Figure 9-17: Spectrum Graphs 230

Figure 9-18: Review Substage Toolbox 232

Figure 9-19: Review Substage Spectrum Tab..... 233

Figure 9-20: Review Substage Evaluation Tab 234

Figure 9-21: Review Substage Tools Tab..... 235

Figure 10-1: Settings Screen..... 239

Figure 10-2: Device and Network Section	240
Figure 10-3: Support Information	241
Figure 10-4: Water System Information	241
Figure 10-5: Water System Control Section	242
Figure 10-6: Profile Management screen.....	243
Figure 10-7: Planning Scan Settings	244
Figure 10-8: Scan Mode Selection.....	244
Figure 10-9: Thermometry Scans Settings	245
Figure 10-10: Thermometry Scans (Advanced).....	245
Figure 10-11: Additional Scans.....	246
Figure 10-12: Sonication Monitoring and Control	246
Figure 10-13: Sonication Monitoring and Control (Advanced)	247
Figure 10-14: Calibration (Advanced)	248
Figure 10-15: Algorithms (Advanced)	248
Figure 10-16: Movement detection (Advanced).....	249
Figure 10-17: Entrance Screen List Management Screen	250
Figure 10-18: Username List Management.....	251
Figure 10-19: Target Location List Management	251
Figure 10-20: Indication List Management	252
Figure 10-21: System Settings Screen (During Treatment and DQA)	253
Figure 10-22: MRI Interface Section.....	254
Figure 10-23: Movement Detection (Advanced) Section.....	255
Figure 10-24: Calibration (Advanced) Section.....	256
Figure 11-1: Offline Replay Screen	258
Figure 11-2: Replay Toolbox.....	259
Figure 12-1: Transducer Handling Procedure	264
Figure 12-2: Transducer and Water System Disinfection Procedure.....	265
Figure 12-3.....	265
Figure 12-4.....	266
Figure 12-5.....	266
Figure 12-6.....	267
Figure 12-7: 'Home' Menu.....	267
Figure 12-8: 'Clean' Menu	267
Figure 12-9: 'Cleaning Tank'	268
Figure 12-10: Fill & Clean Transducer' Screen	268
Figure 12-11: Air Release Valve (open)	268
Figure 12-12: 'Cleaning Transducer'	269
Figure 12-13: Water System Remote Controller.....	269
Figure 12-14: 'Drain Transducer & Front End'.....	269

Figure 12-15: Drain	269
Figure 12-16: 'Draining Front End'	270
Figure 12-17.....	270
Figure 12-18.....	270
Figure 13-1: Database Screen Overview	275
Figure 13-2: Main Database Window.....	277
Figure 13-3: Treatment Summary Table Screen.	278
Figure 13-4: Database Pull-Up Toolbox.....	279
Figure A - 1: Water fitting disconnection	289
Figure A - 2: (L) Water pouch and Silicone tube with fittings, (R) Air release Valve opening.....	289
Figure B-1: Research Hard Drive Set + Dedicated Key.	291
Figure B-2: Release and removal handle of Hard Drive	292

This page is intentionally left blank for double-sided printing.

1. SYSTEM OVERVIEW

1.1. Introduction

The **Exablate® Model 4000 Type 1.1** (“Exablate”, “Exablate Neuro”, “Exablate Prime” or “the system”) is a transcranial, magnetic resonance, image-guided focused ultrasound (MRgFUS) system that is designed for Incisionless ablation of brain tissue. The system is comprised of a detachable Transducer System that is mounted on general purpose MR Table and controlled via a dedicated console in the MR control room.

Focused ultrasound energy is repeatedly transmitted to the target region, gradually heating the tissue at the focal spot of the ultrasound beams until the target tissue is ablated and the desired outcome is achieved, while nearby tissue remains unaffected.

Targeting is accomplished using magnetic resonance (MR) images taken during the treatment. The treatment process is constantly monitored by real-time closed-loop thermal feedback under full control of the treating physician. Once the treatment is complete, the treatment outcome is confirmed with immediate post treatment MR imaging sequences.

The system is designed to interface with GE, Siemens and Philips MR systems (1.5T and 3T Scanners, with various types of magnets, software and hardware interfaces). **For detailed Intended Use/Indications for Use/ Intended Purpose refer to the Information for Prescribers (IFP) document provided with this Operator’s Manual.**

Instructions as defined herein pertain to commercial use. Clinical or pre-clinical research requires further dedicated instructions and training.

1.2. Intended Users

The system may only be operated by Neurosurgeons – physicians qualified and certified for performing interventional procedures in the brain.

Specifically, for an Exablate procedure, the following tasks will be exercised:

- Placement of head frame & pins for Patient's head fixation.
- Determination of the intended target location to treat based on MRI images.
- Patient management during the procedure, including assessing therapeutic benefits and potential adverse events.

Operators must be proctored by Insightec till completion of their Insightec Exablate training program.

1.3. Document Conventions

Notes, Cautions and Warnings are used throughout this manual to highlight important points of information that impact the health and safety of the patient and operator, as well as information intended to preserve system integrity. The following are examples of these messages:



NOTE:

Notes provide information to aid in obtaining optimum equipment performance.



CAUTION:









Cautions indicate instructions or cautionary notes that, if not followed, may result in damage to the equipment or to the quality of treatment.



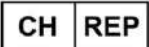













WARNING:









Warnings indicate precautions and instructions which, if not followed, may result in personal injury or even death.





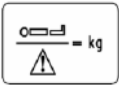

1.3.1. Symbols Glossary



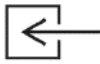
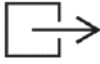

Symbol	Symbol Title	Description	Standard Reference
	CE mark	Designates that the product labeled is authorized for sale in EU.	2017/745
	Authorized representative in the European Community	This symbol shall be accompanied by the name and address of the authorized representative in the European Community.	ISO 15223-1, clause 5.1.2
	Authorized representative in Switzerland	This symbol shall be accompanied by the name and address of the authorized representative in Switzerland.	MB_Obligations_Economic_Operators_CH, section 6
	Prescription devices	Caution: Federal law restricts this device to sale by or on the order of a physician / special practitioner.	21 CFR 801.109 21 CFR 801.15(c)(1)(i)F
	Manufacturer	This symbol shall be accompanied by the name and address of the manufacturer.	ISO 15223-1, clause 5.1.1
	Date of manufacture	This symbol shall be accompanied by a date to indicate the date of manufacture.	ISO 15223-1, clause 5.1.3
	Use-by date	This symbol shall be accompanied by a date to indicate the expiration date.	ISO 15223-1, clause 5.1.4
	Batch code	This symbol shall be accompanied by the manufacturer's batch code. The batch code shall be adjacent to the symbol.	ISO 15223-1, clause 5.1.5

Symbol	Symbol Title	Description	Standard Reference
	Serial number	This symbol shall be accompanied by the manufacturer's serial number.	ISO 15223-1, clause 5.1.7
	Catalogue number	The manufacturer's catalogue number shall be adjacent to the symbol.	ISO 15223-1, clause 5.1.6
Model	Model/ Type designation	The name and/or number used to represent one medical device, or a family of medical devices to group many variations that have shared characteristics.	IMDRF/RPS WG/N 19:2016
	Keep away from sunlight/ Keep away from heat	Indicates a medical device that needs protection from light sources.	ISO 15223-1, clause 5.3.2
	Keep dry	Indicates a medical device that needs to be protected from moisture.	ISO 15223-1, clause 5.3.4
	Lower limit of temperature	The lower limit of temperature shall be indicated adjacent to the lower horizontal line.	ISO 15223-1, clause 5.3.5
	Temperature limit	The upper and lower limits of temperature shall be indicated adjacent to the upper and lower horizontal lines.	ISO 15223-1, clause 5.3.7
	Humidity limitation	Indicates the range of humidity to which the medical device can be safely exposed.	ISO 15223-1, clause 5.3.8

Symbol	Symbol Title	Description	Standard Reference
	This way up	This way up	ISO 7000-0623
	Do not re-use	Indicates a medical device that is intended for one use, or for use on a single patient during a single procedure.	ISO 15223-1, clause 5.4.2 IEC 60601-1 Ed 3.2 Table D.1 (28)
	Caution	Indicates the need for the user to consult the instructions for use for important cautionary information such as warnings and precautions that cannot, for a variety of reasons, be presented on the medical device itself	ISO 15223-1, clause 5.4.4 IEC 60601-1 Ed 3.2 Table D.1 (10)
	General Warning (There is a certain danger)	To be placed together with a supplementary symbol or text.	IEC 60601-1: Ed 3.2 Table D.2 (2)
	General mandatory action	To be placed together with a supplementary symbol or text	IEC 60601-Ed: 3.2 Table D.2 (9)
	Follow instructions for use	Refer to instruction manual/ booklet	IEC 60601-Ed: 3.2 Table D.2 (10)
	Warning, electricity	Dangerous voltage	IEC 60601-1 Ed3.2 Table D.2 (3)

Symbol	Symbol Title	Description	Standard Reference
	WEEE- waste of electrical and electronic equipment	Discard the electrical and electronic equipment according to local regulation policy	Directive 2012/19/EU
	Type BF applied part	Degree of Protection against electric shock (Type BF Applied Part)	IEC 60601-1: 3.2Ed Table D.1 (20)
	Type B Applied Part	Degree of Protection against electric shock (Type B Applied Part)	IEC 60601-1: 3.2Ed Table D.1 (19)
	Body weight	To identify the control or the indicator to enter or call up the body weight of a person	IEC 60417-5665
	Safe working load	Safe working load	IEC 60417
	Alternating current	Indicating the rating plate that the equipment is suitable for alternating current only; to identify relevant terminals.	IEC 60601-1: 3.2Ed Table D.1 (1)
	Three-phase alternating current	Indicating the rating plate that the equipment is suitable for three phases alternating current only; to identify relevant terminals.	IEC 60601-1: 3.2Ed Table D.1 (2)
	Three-phase alternating current with neutral conductor	Indicating the rating plate that the equipment is suitable for three phases alternating current with neutral conductor only; to identify relevant terminals.	IEC 60601-1: 3.2Ed Table D.1 (3)

Symbol	Symbol Title	Description	Standard Reference
	Protective earth (ground)	Identifying any terminal, intended for connection to an external conductor for protection against electric shock in case of a fault, or the terminal of a protective earth (ground) electrode.	IEC 60601-1: 3.2Ed Table D.1 (6)
	Input; entrance	Indicating an entrance (e.g. hydraulic pump).	ISO 7000-0794
	Output; exit	Indicating an exit (e.g. hydraulic pump).	ISO 7000-0795
	Method of sterilization	Method of sterilization using ethylene oxide.	ISO 15223-1, clause 5.2.3
	MR Safe	Indicates that the device is safe- it poses no risks in any MR environment.	FDA guidelines for testing and labeling of medical devices in MR environment
	Medical device	Indicates the item is a medical device	ISO 15223-1: clause 5.7.7
	Do not use if package is damaged	Indicates a medical device that should not be used if the package has been damaged or opened.	ISO 15223-1: clause 5.2.8
	Consult instructions for use or consult electronic instructions for use	Indicates the need for the user to consult the instructions for use	ISO 15223-1: clause 5.4.3

Symbol	Symbol Title	Description	Standard Reference
	MR Conditional medical devices	Indicates that the device is MR conditional - A medical device with demonstrated safety in the MR environment within defined conditions	FDA guidelines for testing and labeling of medical devices in MR environment
	Do not re-sterilize	Indicates a medical device that is not to be re-sterilized.	ISO 15223-1, clause 5.2.6
	Model number	Indicates the model number or type number of a product	ISO 15223-1, clause 5.1.10
	Unique Device Identifier	<p>A unique numeric or alphanumeric code that consists of two parts:</p> <ul style="list-style-type: none"> • A device identifier (DI) • A production identifier (PI) 	<p>ISO 15223-1, clause 5.7.10</p> <p>21 CFR 801.40</p>

1.4. Scope of This Manual

This operator's manual covers the Exablate system for the following configurations:

- Trade name: Exablate
- Model: 4000
- Cradle Type: 1.1
- Software version: 9.01
- MRI magnetic field strength: 1.5T / 3.0T

1.5. System Characteristics

1.5.1. Specifications

- Tissue destruction mechanism: Thermal coagulation necrosis
- Planning: Treatment planned on multiple MR Images either by multiple acquisitions (i.e. along Coronal, Axial and Sagittal planes) or by reformatting of a single volumetric scan.
- Area measurement: The system allows the operator to measure an area on an image, and indicates the STD & mean within that area.
- Movement monitoring: Movements above 2mm (per axis, compared to reference image acquired during Planning) cause a safety halt.
- Reflection monitoring: None (data collection only)
- Cavitation monitoring: Passive cavitation detection, real time display; Sonication automatically halted if excessive cavitation is detected.

SPECIFICATION	STANDARD MODE
Transducer	<i>1024 element annular sectored phase array</i>
Transducer aperture (diameter)	<i>300mm</i>
Transducer radius of curvature	<i>150mm</i>
Focal distance	<i>135 – 165 mm (achieved by electronic steering)</i>
Frequencies	<i>620 – 720 kHz</i>
Frequency control	<i>Accuracy of +/-1kHz</i>
Energy range	<i>60 kJ/a</i>
Effective radiating area (ERA)	<i>1400cm²</i>
Focal region size	<i>~1.5 x 1.5 x 3 mm</i>
Focal control	<i>Electronic</i>
Imaging during treatment	<ul style="list-style-type: none"> • <i>PRF MR Images at 5 seconds interval or less</i> • <i>Spatial in-plane precision of 1.1 mm or less</i> <p style="text-align: center;"><i>Anatomical image (Magnitude) SNR are >7</i></p>

Water Temperature measurement	<i>Active head cooling by cooled water (15°C default) circulation monitored with +/-1°C accuracy</i>
Thermal Imaging/Targeting accuracy	<i>Detection of the thermal spot center with 1mm accuracy</i>
Tissue Temperature measurement	<i>Proton Resonance Frequency (PRF) MR thermometry accuracy <2°C in all scan orientations</i>
Movement monitoring	<i>Accuracy of ~1mm</i>
Energy density in target (trans-skull)	<i>~ 400-800 W/cm²</i>
Ultrasound output	<i>~1500Wa</i>
Effective strength	<i>~1 W/cm²</i>
Amplitude control	<i>Accuracy of +/-1Vrms or +/-15%</i>
Phase control	<i>Accuracy of +/-15°</i>
Calibrated power	<i>Accuracy of +/-30%</i>
Max. output pulse duration	<i>60 sec</i>
Sonication duration	<i>8 - 60 sec</i>
Duty cycle	<i>1</i>
Cooling time	<i>300sec/10KJ transmitted</i>

1.5.2. Treatment Outcome Monitoring Method:

Treatment outcome monitoring is provided by three different methods:

- Using real time thermometry, the operator gets real time feedback on treatment outcome, as temperature is correlated to tissue viability.
- Independent assessment using standard MR imaging sequences is performed during and after treatment to assess ablation size and location.
- Neurological evaluation during and after the treatment provides a clinical assessment.

1.5.3. System Electrical Specifications:

- Rated power voltages: 380-400V / 480V
- Number of phases: 3 phases
- Rated power frequency: 50/60Hz
- Rated power input: ~28kVA
- Protection against electric shock: Applied Part Type B



WARNING:

W001

Deviation from compliance with the guidelines and methods detailed in this document and official InSightec documentation may cause serious injury to operator and/or patient and compromise treatment efficacy. All equipment must be operated by professionals trained by InSightec.

1.5.4. System and Kits Environmental Conditions

System Operating Conditions:

	Equipment Room	Magnet Room	Operator Room
Temperature range	15-32°C	10-22°C	15-32°C
Relative humidity	≤ 80%	≤ 75%	≤ 75%

- Atmospheric pressure: 700 to 1060 hPa
- Altitude: -30 m (-100 ft.) to +3000 m (+9800 ft.)

System Storage & Transportation Conditions:

- Temperature range: 5 to 40°C
- Relative humidity: ≤ 90%
- Atmospheric pressure: 700 to 1060 hPa

Kit Transportation Conditions:

- Temperature range: 5 to 50°C
- Relative humidity: 15%-90%
- Atmospheric pressure: 700 to 1060 hPa

Kit Storage Conditions:

- Temperature range: 15 to 25°C
- Relative humidity: 40%-80%
- Atmospheric pressure: 700 to 1060 hPa

1.5.5. Effects of the System acoustic output levels on living tissue

- This equipment is used to cause tissue coagulative necrosis by heating using focused ultrasound.
- Low output level is used for targeting, without reaching coagulative necrosis.
- Dose level output generates coagulative necrosis of the targeted tissue, at the prescribed size.
- Excess output level will cause a larger than planned spot size and are prevented by the system's safety mechanisms.

1.6. System Components

1.6.1. Overview

The Exablate Neuro system consists of the following integrated components:



WARNING:

W002

The use of accessories, transducers, and cables other than those specified or provided by InSightec of this equipment may result in increased electromagnetic emissions or decreased electromagnetic immunity of this equipment and result in improper operation.

In the Operator Room:

- Operator Console
- Workstation

Inside the MRI Suite:

Front End Unit (FE)

- Power and Water Cables

Helmet System (HS):

- Transducer
- Mechanical Positioner
- Frame Fixation Posts
- Power and Water Cables
- MR Tracking and Head Coil Connector/s
- Patient Stop Sonication Button

Storage and Transfer Cart (STC)

Exablate MRI Table Adapter Baseplate

Water System

- Water System Control Touchscreen (within FE)
- Water Reservoir (within FE)
- Water System Remote Controller (attached to FE).

In the Equipment Room:

Equipment Cabinet

Water System Components:

- Water Chiller

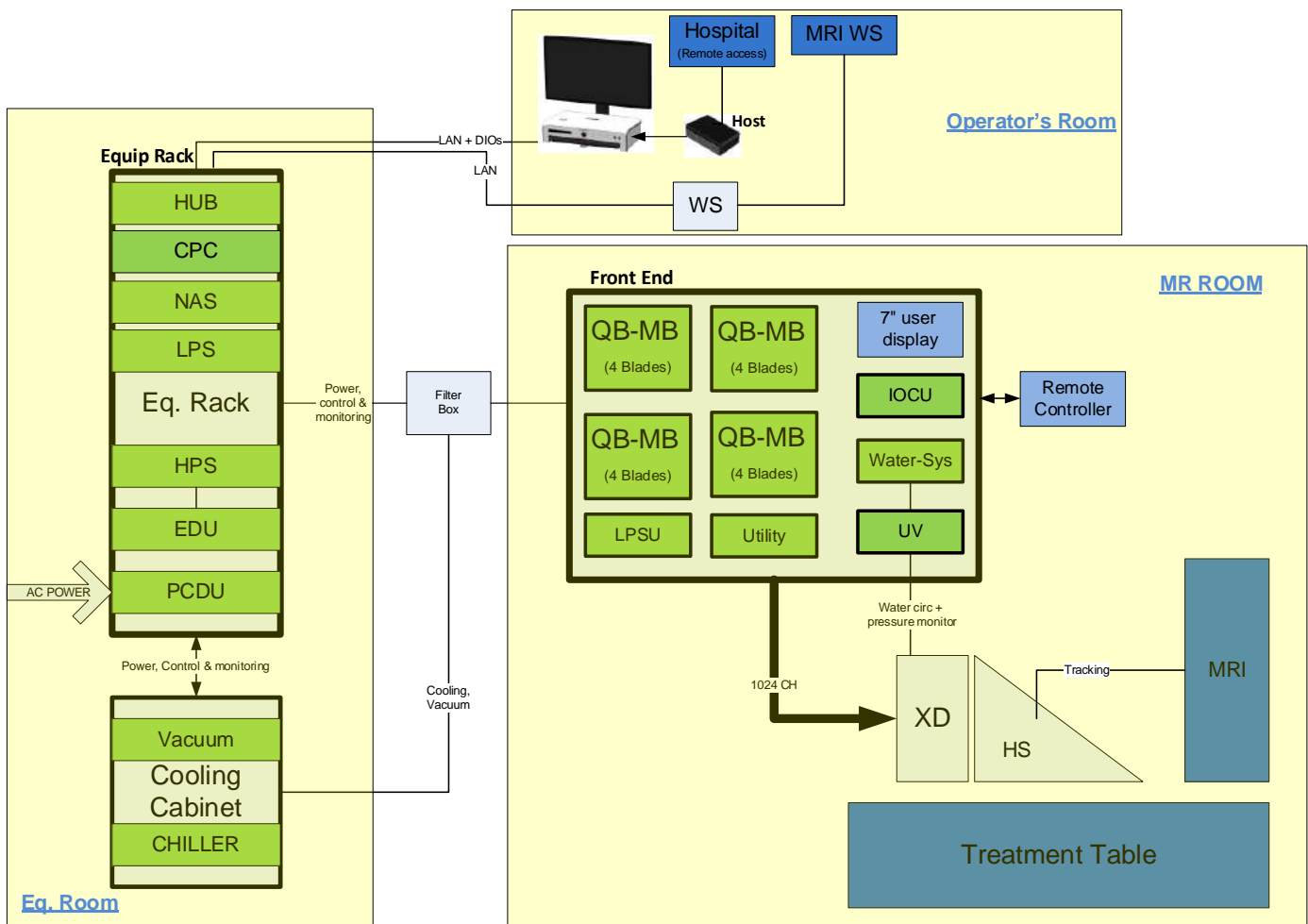

Figure 1-1: Schematic representation of system component layout on-site

1.6.2. Operator Console Workstation

The Exablate Neuro Operator Console allows the operator to control and monitor both the system and the treatment. It is positioned alongside the MR Workstation in the control room. The Exablate software is controlled by a standard mouse and keyboard combination. The operator console is fitted with indicators on water system and system power states and an Operator Stop Sonication button. It is fitted with USB ports and a DVD R/W drive for importing and exporting images and technical data.



NOTE:

N076D

The two USB ports located on the front side of the Operator's console are only intended for import & export of treatment data.



Figure 1-2: Exablate Neuro Operator Console Workstation

The back of the console is fitted with the following power\reset buttons

- Power cord – unplug to RESET console PC
- Small blue push button next to monitor base – press to power console ON\OFF
- Physical recessed button - Workstation physical RESET button

These are only intended for troubleshooting and service use.

1.6.3. Front End Unit

The Front End (FE) Unit incorporates the electronic systems that drive the ultrasonic transducer. It is located in the magnet room and is connected to the Equipment Cabinet.

The unit can be moved around the room, within a limited area.

The FE is equipped with a connector panel holder to store the Detachable Cable Connector Panel for easier cable management.

The FE Rack also includes a built-in display to control and monitor the water system.

The water reservoir is stored inside the FE Rack and is accessible from a door located at the front right-hand side of the Rack

The Front End Unit must be kept at a safe distance from the MRI bore (If brought within the distance threshold, the MRI Proximity Light on the Front End Unit will turn on). Only authorized InSightec service personnel or site personnel trained by InSightec are qualified to define the FE Treatment Position, and its Idle Area, and to disconnect this unit or move it out of the magnet room.

FE Harnesses - When the Front End Unit is stored away from the MRI Suite, the harness connectors may be disconnected by the site personnel after being trained to do so.



Figure 1-3: Examples of Front End Unit configurations (For illustration only)

1.6.4. Exablate Treatment table components

MRI Table Adapter Baseplate

The Exablate MRI Table Adapter Baseplate facilitates connecting the Exablate Transducer along with its Mechanical Positioning and Frame Fixation Unit. It contains a basin that retains spilt water in the case of an emergency patient evacuation (see Section **2.2.4, Patient Emergencies**). Different MR scanner models and makes may have different Baseplates adapted for them.



Figure 1-4: MRI Table Adapter Baseplate (for illustration purposes only)



NOTE:

N110

Ensure the MR table is clear of any other accessories prior to placement of the baseplate.

Helmet System

The Helmet System (HS) is fixed onto the MR Table Baseplate during the treatment and incorporates the focused ultrasound Transducer, the Mechanical Positioning System that allows manipulation of the transducers positioning and pitch in place, and the Frame Fixation Posts that keep the patient's head immobilized during treatment. The Helmet System connects to the Front End Unit via the Power and Water cables.

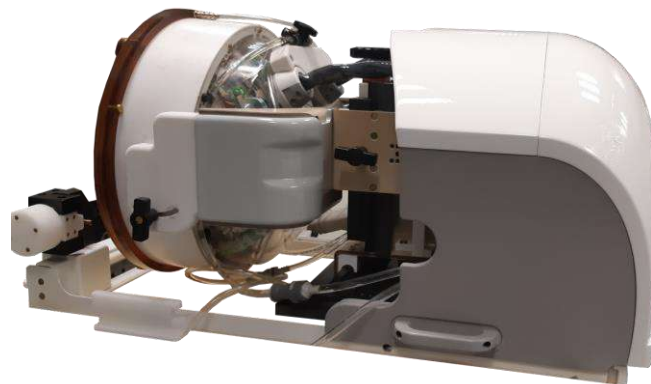

Figure 1-5: Helmet System

1.6.5. Patient Stop Sonication Button

The **Patient Stop Sonication Button** immediately interrupts the treatment by stopping the sonication and the MR scanning. It is connected to the helmet system.



Figure 1-6: Patient Stop Sonication Button



WARNING:

W055

At certain time slots, when the system is busy, the patient stop sonication button may become unresponsive.

An alert message will be displayed in the wait message area on the screen to pay attention to the patient while this message is displayed. Failing to comply with the above may result in patient injury.

This does not apply to the sonication itself. As the button is always online throughout energy delivery.



NOTE:

N058

The Stop Sonication button must be inflated in order to be responsive. Make sure the user is instructed to let go after pressing it.

When not in use, wrap the cable around the Frame Holder and put the sonication button in its dedicated holder.

After each use, use IPA 70% (isopropyl alcohol 70% in water) to clean and disinfect the stop sonication PVC rubber bulb.



CAUTION:

C001

Failing to stow the Patient Stop Sonication-Button as described above, may lead to damage when transferring the Helmet System to or from the STC

1.6.6. Storage and Transfer Cart (STC) with Detachable cable connector panel

The STC houses the Helmet System when it is not in use. It is fitted with wheels and can be locked in place and may be stored inside or outside the MRI Suite. It includes a coupling mechanism for latching onto the MRI Table and transferring the Helmet System onto the MRI Baseplate.

The Detachable cable connector panel is mounted on the Connector panel holder on the front of the STC and is meant to assist in the process of connecting the cables to the Front End, as well as keeping the connectors protected when the system is not in use. The cable connector panel can be used to carry the cables over to the Front End, where it can be held in another Connector Panel Holder.



Figure 1-7: STC Cart Without (Left) and with (Right) Helmet System

1.6.7. Exablate Water System

During an Exablate Neuro treatment, the part of the patient’s skull transversed by the ultrasound beams is immersed in water to facilitate ultrasound transmission and ferry heat away from the skull.

The water system offers a semi-closed water circulation loop, enabling filling and draining of the transducer water interface, preparing, and circulating the water during treatment (while keeping it cooled and degassed) and performing a cleaning procedure following the treatment.

The portable water reservoir holds up to 14 liters (3.7 US gallons) of water and is housed inside the designated Water Reservoir Compartment in the Front End Unit.

During treatment, when the MR is not scanning, this water is circulated and degassed by the Water Chiller, located in the equipment room.

The various modes, states, and parameters of the Water System (See Section 10.2.6, **Water System Control**) can be controlled via the Workstation Software, or by the dedicated **Water System Control** touch-screen located on the FE.

Water system states can also be controlled via the Water System Remote Controller.

For further details regarding the water system interface, refer to Section 3.5, **Operating the Water System**.

For further details regarding water system maintenance and the cleaning procedure, see the **CLEANING AND DISINFECTION** Chapter.

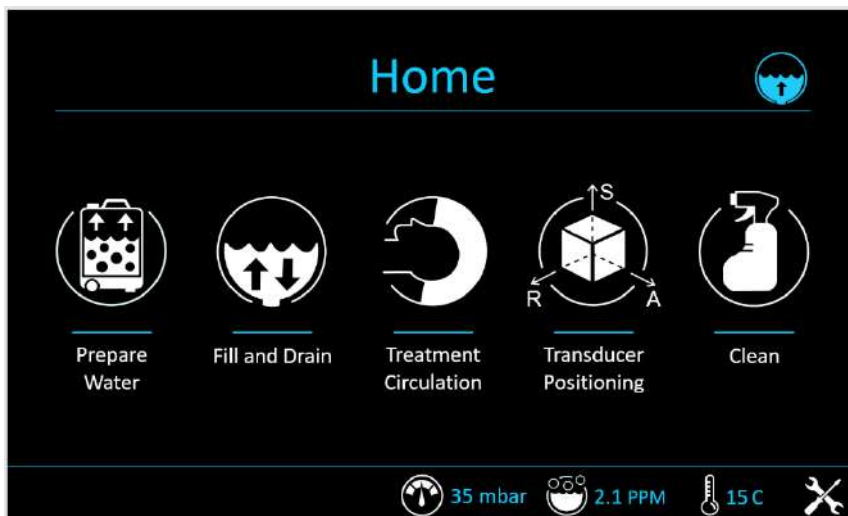

Figure 1-8: Water System Control 'Home' Screen (L) and Chiller (R) (For illustration only)

1.6.8. Equipment Cabinet

The Equipment Cabinet incorporates the electrical components of the Exablate Neuro system and the main power switch. This unit is usually located in the MRI equipment room.

Do not interact with the equipment cabinet. Only authorized InSightec service personnel are qualified to move, disconnect or service this unit.



Figure 1-9: Exablate Neuro Equipment Cabinet (illustration)



NOTE:

N001

The red Emergency Power-Down Button on the bottom of the equipment cabinet is to be pressed in case of emergency for complete power down (e.g. in event of a fire or electrical short-circuit).

1.6.9. Key Exablate 4000 Treatment Components

For each treatment, ensure the following components are available:

- 1 x Exablate Neuro Patient Membrane (an elastic membrane which seals the transducer and enables acoustic interface between the transducer and the patient's head). Two types of membrane are available and will be provided according to your system configuration.
 - Membrane without coil
 - Membrane with coil (See **section 1.8, Head Coil Specifications**)
- 1 x Exablate Neuro DQA Phantom Gel (1 gel required per treatment day)
- Set of 4 x Disposable Head Frame Screws and Head Frame Screw Adapters (See **Section 1.7, Exablate Head Frame Instructions for Use**)
- 1 x Exablate Neuro Treatment Accessories Kit (optional, for troubleshooting)
- One Neuro Head Frame set, as supplied with the system, see detailed components description in the relevant Head Frame section

The treatment components are provided compatible with your exact system configuration (Exablate 4000 model, MR type & field strength).

For applicable part numbers please refer to the Part Numbers file provided with the system or available on demand.



WARNING:

W005

Treatment kit and accessory compatibility may vary per MR and system type.

Please contact the InSightec representative to ensure system compatibility with the relevant components. Discard single use accessories following treatment.



WARNING:

W003

Do not use accessories which are incompatible with your exact system configuration (Exablate 4000 model, MR type & field strength).



WARNING:

W004

Inspect treatment kit components before use. If a component is damaged, do not use it and discard according to local regulation.

1.6.10. General Accessories for Exablate 4000

List of accessories supplied with the system (as per specific system configuration).

DESCRIPTION	CONTENT PURPOSE DESCRIPTION
Hose with adapter: threaded tap	For easier filling of the water tank
Hose with adapter: flexible tap	For easier filling of the water tank
Manual Drain Kit	Used to manually drain water from transducer in the event of mains power loss during procedure.
Landmark Labels	Landmark Label Sticker
DQA Setup Kit	Case including DQA Phantom Gel holder head frame adapters fit for the Exablate system
DQA Setup Membrane mounting Jig	For assembly of Head Coil on DQA setup, to allow QA for specific Head coil. For use with DQA Setup Kit
Hose with funnel for Water tank	For easier filling of the water tank
Cable holders	To hold cables in place (PHILIPS systems only)
Landmark accessory	To assist in recovery of lost landmark (PHILIPS systems only)

1.6.11. Head Frame Types

Please refer to the Head Frame instruction for use chapter relevant for the headframe model supplied with your Exablate System.



Exablate Head Frame Base	UCHRA ("INTEGRA") Head Frame Base
 <p>Refer to Exablate Head Frame Instructions for Use</p>	 <p>Refer to information Information for owners of UCHRA (INTEGRA) Head Frame</p>

Figure 1-10: Head Frame Types

1.7. Exablate Head Frame Instructions for Use



WARNING:

W117D

Determine applicable configuration as described in Section **Head Frame Types** and refer to relevant documentation only.

1.7.1. Exablate Head Frame

This section describes how to properly assemble, use, handle and maintain the Exablate Neuro Head Frame. Read and become familiar with these instructions before using InSightec’s Head Frame.

The Exablate Neuro Head Frame is used for the fixation of the patient’s head to the treatment table during treatments with the Exablate 4000 System. The Exablate Head Frame is MR Conditional. Always inspect Exablate Neuro Head Frame prior to use. Do not use if damaged. It is intended for use exclusively with InSightec PFK (Patient Fixation Kit) head frame pins.



WARNING:

W006

The Exablate Neuro (and UCHRA based) head frames are non-stereotactic headframes, intended for use only for Exablate Neuro treatments, in conjunction with the InSightec Patient Fixation Kit (PFK).



WARNING:

W007

Perform a visual inspection prior to using the frame, and ensure all screws are fully tightened. Contact InSightec in case the frame is dropped, or any damage is detected. Do not use if damaged!



WARNING:

W118

The disposable Head Frame Screws and adapters are provided **STERILE** (following sterilization using Ethylene Oxide).

- Visually inspect screw package before use to verify the integrity of sealing. Discard of screws in case of tears, punctures or other visual damage to package or components.
- Head Frame Screws and Adapters are intended for single use only. Do not re-use or re-sterilize. Re- use may result in cross contamination, and in dullness of the screw, leading to potential patient movement.
- Dispose the screws and all 8 adapters according to hospital and local laws.



WARNING:

W009

The Head Frame is to be used within an MR device. It should not contact the patient. Maintain a gap between the Head Frame and the patient’s skin to avoid RF burns.



NOTE:

N002

Be sure to gather the small miscellaneous parts (such as screws, wrenches, and accessories) following use to prevent loss.



NOTE:

N003

For Instructions of the UCHRA (INTEGRA) based Head Frame previously supplied with Exablate systems, see section 1.7.9 **Information for owners of UCHRA (INTEGRA) Head Frame**

1.7.2. Exablate Neuro Head Frame Set



CAUTION:

C042

The Exablate Neuro Head Frame is already assembled in its case to the Head Frame posts. Make sure they are strongly tightened to the head frame base.



NOTE:

N005

Post position can be adjusted according to patient's anatomy. Note that there are two provided options for frontal fixation – an anterior bar, or separate posts. The selection of the proper fixation set is at the discretion of the treating physician.

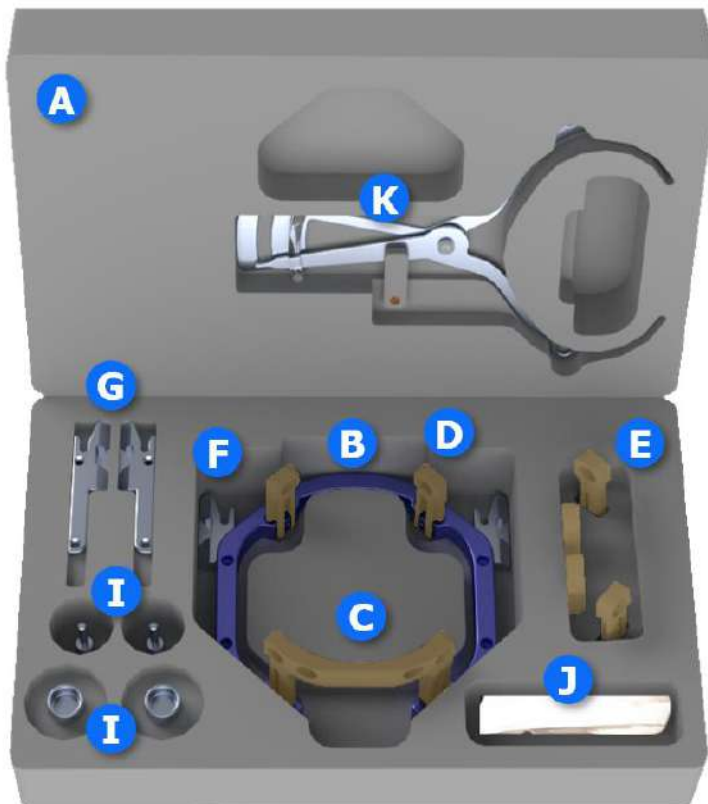

- A** Head Frame Set Case
- B** Head Frame base
- C** Anterior Frontal Bar
- D** Posterior posts (2 sets)
- E** Anterior posts
- F** Side Holders
- G** Short Side Holders
- H** Patient Fixation Wrench
- I** Frame Assembly Wrench
- J** Frame Placement Straps
- J** Exablate Caliper

Figure 1-11 The Exablate Frame Set

1.7.3. Exablate Neuro Patient Fixation Kit (PFK)

The PFK (Patient Fixation Kit) is composed of 4 Patient Fixation Screws, 4 Short Adapters and 4 Long Adapters (Figure below). The adapters offer a sterile interface for the screws and provide compatibility with a wide range of head sizes. As shown in the figures below, the Screws and Adapters are assembled onto the posts of the Exablate Head Frame via dedicated fixation holes.

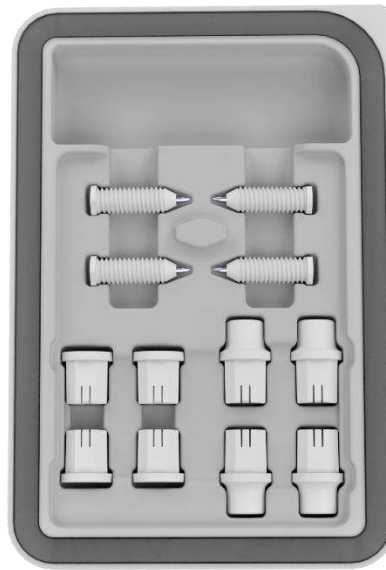

Figure 1-12: Exablate Neuro Patient Fixation Kit (PFK)

1.7.4. Exablate Caliper

The Exablate Caliper is an optional accessory that assists in the determination of the optimal adapter combination to use (Section 1.7.5, **Different Adapter Combinations**), by measuring the patient's head



diagonal (See

Figure 1-13: Exablate Caliper for Head diagonal measurement and combination estimation) from front pin insertion location to its contralateral posterior pin insertion location on patient’s head).

The Caliper has a range of three different intervals for 3 types of head size: SS, SL, LL (1.7.5, **Different Adapter Combinations**).

In order to choose the right combination of adapters to insert in the frame fixation holes, use the caliper provided in the Head Frame Set (Section 1.7.2, **Exablate Neuro Head Frame Set**) on a shaved patient’s head.



Figure 1-13: Exablate Caliper for Head diagonal measurement and combination estimation

1.7.5. Different Adapter Combinations

The Exablate Caliper enables identification of the optimal adapter combination for each patient. As shown in figure 1-13. (Section 1.8.5, **Head Coil Configurations**)

Using the provided caliper (Section 1.8.5, **Head Coil Configurations**), measure the distance between contralateral pin insertion points (e.g. the distance between the left posterior and right anterior intended fixation locations).

Based on this measurement, the instrument will suggest the appropriate combination of adapters (see below). In case a mixed selection is chosen, determine appropriate placement (short in front/back) to optimize frame position.

Note that in case of abnormal or asymmetric patient anatomy, a different combination may be optimal for each pair (diagonal).

Caliper reading: SS	Caliper reading: SL	Caliper reading: LL
Short Adapters	Mixed Adapters	Long Adapters

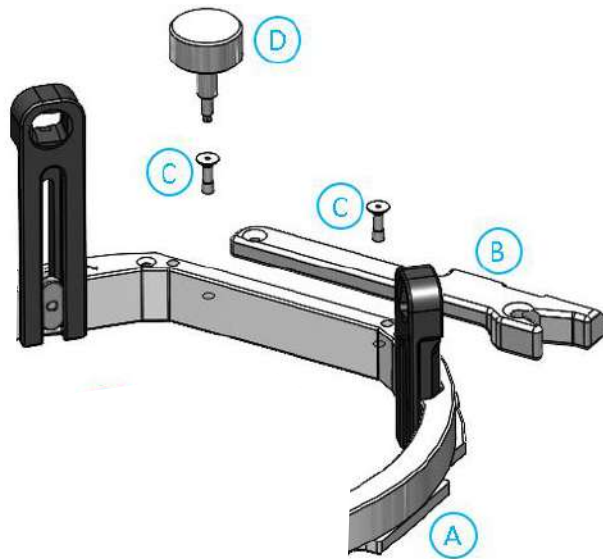

Figure 1-14: Adapter Combinations

1.7.6. Replacing the Side Holders

The Exablate Head Frame set includes two sets of side holders.

The Short side holders allow extending the reach of the transducer along the A-P direction and are especially relevant if aiming for an anteriorly located target in a 60cm MR bore. An informed choice of side holders may also help maximize patient comfort.



	Part Name	Qty.
A	Headframe Base	1
B	Side Holders	2
C	Side Holder Fixation Screws	4
D	Head Frame Assembly Wrench	1

Figure 1-15: Connecting Side Holders to the Headframe (for illustration purposes only)

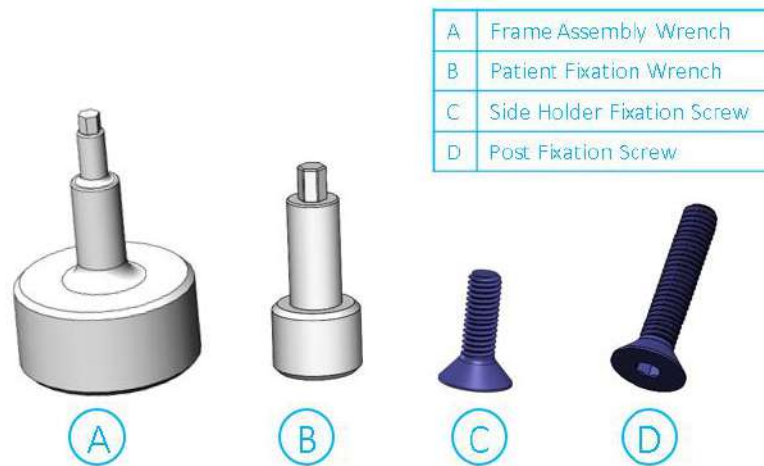

Figure 1-16: Head Frame Screws and Wrenches

1.7.7. Preparing the Head Frame for patient's head

According to patient's head size anatomy, choose the most suitable post and adapter combination.

Two options for frontal fixation are provided with the Exablate Head Frame – a frontal bar with medial and lateral adapter insertion options, and two separate frontal posts.

Select four adapters (as described in Section 1.7.2, **Exablate Neuro Head Frame Set** and Section 1.7.5, **Different Adapter Combinations**), and insert adapters (C/D) to their dedicated fixation holes (B) on the Head Frame posts from the internal side of the posts (See Figure 1-22)..

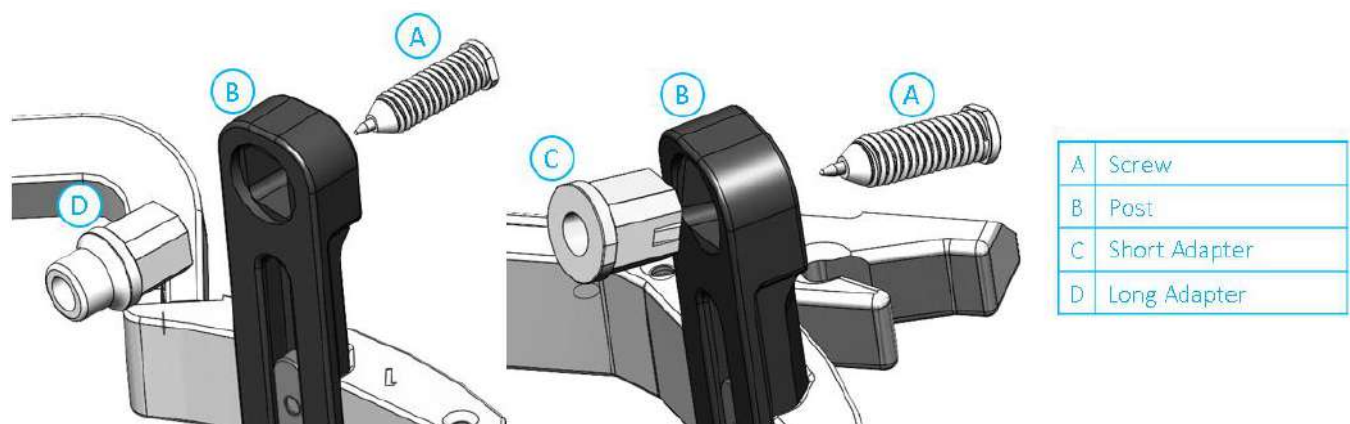

Figure 1-17: Internal Adapter insertion to posts



WARNING:

Ensure each post is thoroughly fastened and that the adapters are fully inserted into the head frame posts.

W010

If necessary, use the Head Frame Assembly Wrenches (**Figure 1-27**) to tighten the posts.

1.7.8. Positioning the Head Frame on the Patient



WARNING:

W109

Headframe fixation may only be performed by a Neurosurgeon with head fixation experience.

- Shave the patient’s scalp thoroughly, then wipe it clean with an isopropyl alcohol soaked gauze or pad.
- Ensure that the posts are tightly fastened.
- Choose the correct 4 adapters according to the guidelines provided in **Different Adapter Combinations Section**.
- Insert the adapters to their predisposed fixation holes on the posts and bar from the internal side of the frame (See **Figure 1-22**)
- (Optional) Use head Frame Positioning Straps to place and adjust the vertical height of the Head Frame.
- Place the Frame as inferiorly as possible to enable optimal coverage for the Exablate treatment.



NOTE:

N006

Using the head frame positioning straps help support the weight of the Head Frame Assembly during placement on the patient.

- Mark with a marking pen the projected screw entry sites and the superior temporal line (optional)
- Apply local anesthesia through the fixation holes in the posts or on marked screws insertion sites, with or without temporarily moving the frame.
- Allow the local anesthetic to take effect.
- Insert the Disposable Head Frame Screws to their predisposed fixation holes in the adapters.



WARNING:

W115D

It is recommended to use an antibacterial ointment on the tips of the screws. Disinfect and bandage the screw insertion sites after removing the headframe



CAUTION:

C003

Four fixation holes in the anterior Head Frame Bar are available for the Disposable Head Frame Screws’ and Adapters insertion. To avoid, if applicable, placement of the screws into the temporalis muscle, use the two medial access points.

- Use the Patient Fixation Wrench provided by InSightec to drive the Disposable Head Frame Screws into the patient's skull.

NOTE:

N007D



Use all four (4) disposable head frame screws to attach the Frame to the Patient

- Only use the Head Frame components and tools provided by InSightec
- Placing the Head Frame assembly is easier if two people perform the procedure.

- Keep a distance between the skin and the outer aspect of the bar at each screw site.
- Tighten the screws: two diagonally opposed screws at a time, alternatively and equally.
- Apply moderate force to ensure the frame is securely tightened to the patient's skull.

CAUTION:

C004D



Overtightening of the Disposable Head Frame Screw can cause premature failure of the head Frame posts and/or the Disposable Head Frame Screw.

Be sure that the spine of the posts does not press against the skin for patient comfort.

WARNING:

W012D



Overtightening of the Disposable Head Frame Screws may cause skull injury:

- Prior to frame application, the treating physician should review details of the patient's CT
- Avoid applying an extra strength during screw insertion on the skull

- Remove the Head Frame Positioning Straps.
- The Patient is now ready for **Patient Membrane** placement.

1.7.9. Information for owners of UCHRA (INTEGRA) Head Frame

The Exablate (UCHRA based) Neuro Head Frame is used for fixation of the patient’s head during treatment with Exablate 4000 System.

This section is intended for users who have the Head Frame variant based upon the INTEGRA UCHRA headframe. This option and is no longer available for purchase and is considered a legacy option.

Do not refer to this section, if you are working with an Exablate Head Frame (such as described in subsections above).

1.7.9.1. Components

Always inspect your Exablate Neuro Head (UCHRA BASED) Frame prior to use. Do not use if damaged.

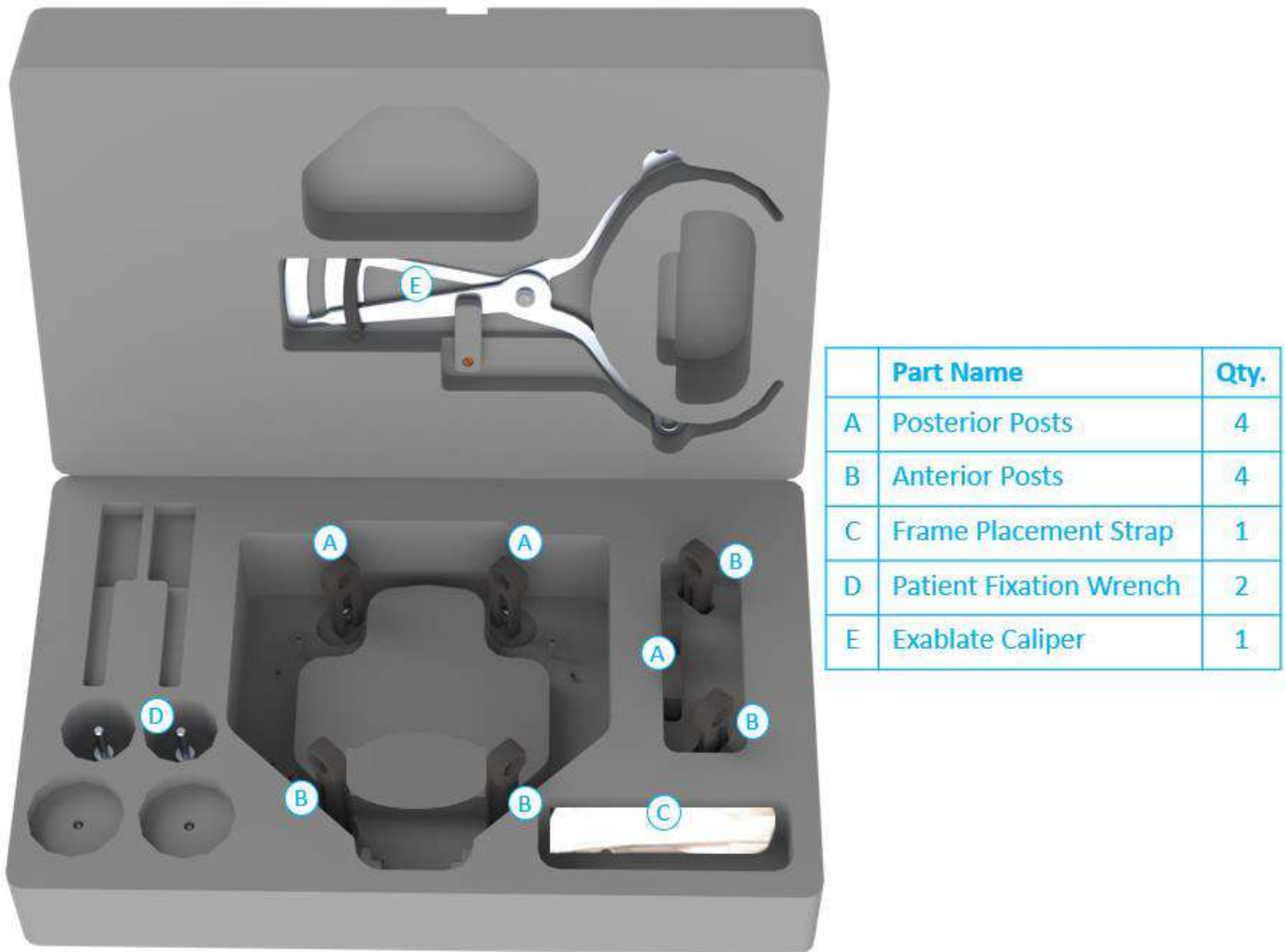

Figure 1-18: UCHRA Frame Components

1.7.9.2. Side Holders

The Exablate Head Frame set includes two sets of side holders.

The Low Side Holders allow extending the reach of the transducer along the A-P direction and are especially relevant if aiming for an anteriorly located target in a 60cm MR bore. An informed choice of side holders may also help maximize patient comfort.

Required Components	
Part Description	Qty
Low Height Head Frame Assy Or Medium Height Head Frame Assy	1
Low Side Hold RH/LH Or Medium Side Hold RH/LH	1
Head Frame Assembling Screw 20 Mm	4
Head Ring Wrench	1

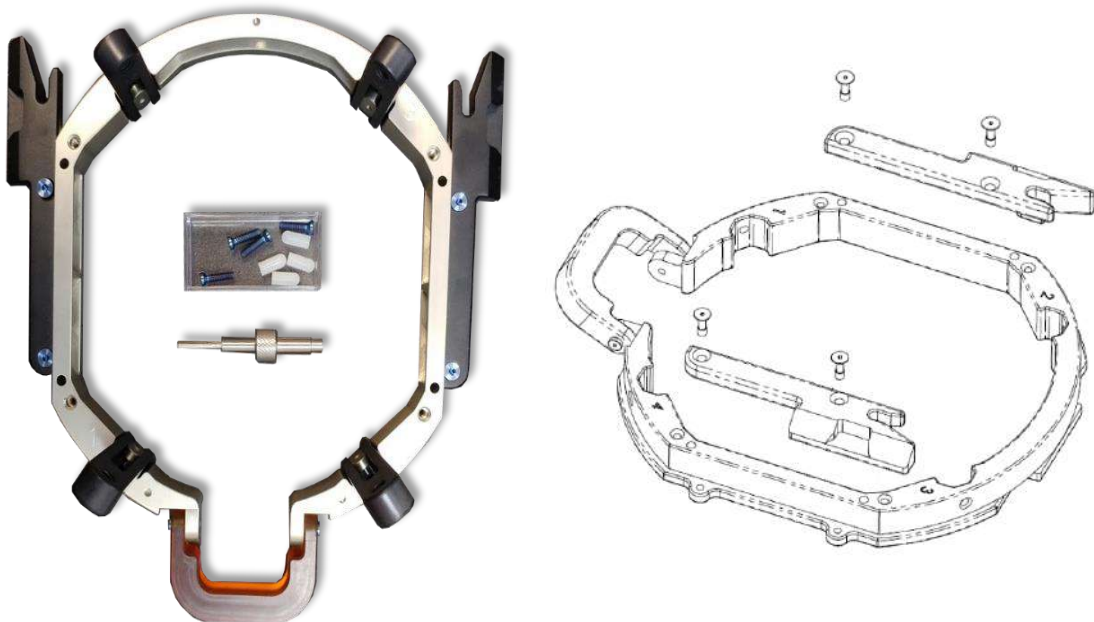

Figure 1 - 13: Connecting Side Holders to the Headframe (for illustration purposes only)

1.7.9.3. Attaching the Support Handles (Posts)

Required Components	
Part Description	Qty
Low Height Head Frame Assy Or Medium Height Head Frame Assy	1
Head Frame Assembling Screw 20mm	4
Anterior Posts	2
Posterior Posts	2
head Ring Wrench	1



Figure 1 - 24: Connecting the frame Posts (for illustration purposes only)



CAUTION:

Note that the Posts are numbered, ensure each post is fastened in the slot marked with the corresponding number.

C002

1.8. Head Coil Specifications

For full Safety precautions, refer to Section 2.4, Head Coil Precautions.

1.8.1. Coil Description

The Exablate 4000 system supports Patient Membranes with integrated 2 channel Head Coils (**Tc MRgFUS Head Coil**) to improve image quality. Each coil type's connector plug is specifically encoded for compatibility with its designated Exablate type and coil connector socket. When connecting the coil, ensure the plug is aligned with the socket.

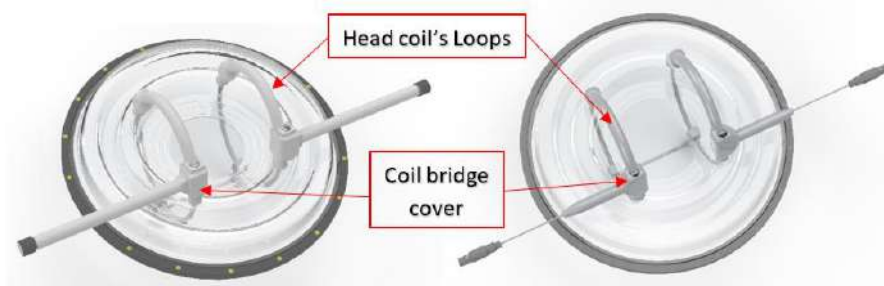

Figure 1-19: Examples of Tc MRgFUS Head Coil



NOTE:

N103

The actual appearance of the MRgFUS Head coil and socket depends on the system type and the treatment kit delivered with the system.

Each coil is comprised of 2 physical loops that are integrated into the Patient Treatment Membrane and are dressed on the patient's head and then connected to Exablate Positioner via a Low Noise Amplifier (LNA) unit that connects to a control unit. All Head Coils are configured with Coil Bridge Cover.

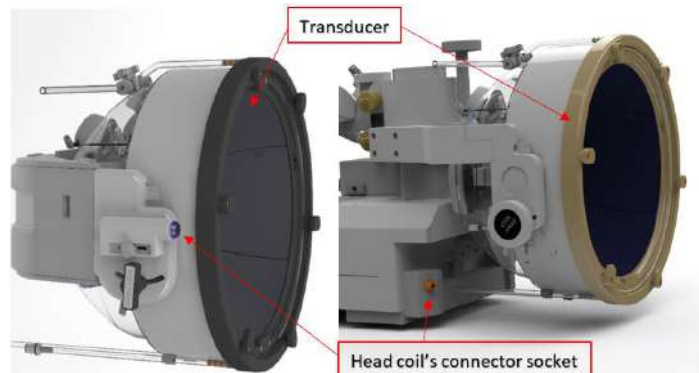

Figure 1-20: Examples of Tc MRgFUS Head Coil Sockets (For illustration only)

1.8.2. Head Coil Connector Socket - Mechanical Adjustment



NOTE:

N011

This section applies to all Tc MRgFUS Head Coil connectors that are mounted on the transducer holder.

The Head Coil Connector socket's position can be adjusted by loosening the coil connector adjustment screw and sliding the socket along the S-I direction. Tighten the screw back to set the socket's position. This can help mitigate pressure applied on the coil or patient.



Figure 1-21: Head Coil connector socket.



Figure 1-22: Coil Connector Plug connecting to the Coil Connector Socket (For illustration only).



NOTE:

N105

The actual appearance of the coil connector depends on system configuration

1.8.3. Coil Classification



Type BF applied part

Class I equipment.

Ordinary equipment.

Suitable for continuous operation.

1.8.4. Troubleshooting

Problem #1: The system does not recognize the coil connection to the system when selected in the software.

Symptoms	Suggested Actions	Resolution
The coil MR connector has become disconnected from the system interface.	Check to make sure the coil MR connector is fully engaged.	Engage connector and try the scan again.

Problem #2: The MR system fails to pre-scan or scan, showing the error: 'The Driver Module Has Detected a Fault'

Symptoms	Suggested Actions	Resolution
One or both of the coil connectors is disconnected.	Check to make sure the coil connectors are connected.	Engage connector and try the scan again.

Problem #3: The coil exhibits poor image quality on patient scans.

Symptoms	Suggested Actions	Resolution
The coil has a high noise level.	Check coil shape, it should be close to a circle. Any significant distortion of the shape might cause significant signal loss or detuning of the coil.	If the coil is defective, return the coil for service.
The coil has low signal.		
Dark bands are observed in the images.		

1.8.5. Head Coil Configurations

1.5T Systems are configured to work only with the head coil configuration.

3T Systems supporting head coils are configured to work in different possible coil configurations; 'HEAD', 'BODY (Head Connected)' (if applicable) and 'BODY' (see Section 10.5, System Settings (Treatment Mode)). Different scenarios are described below.



Figure 1-23: Examples of MR connectors

Scenario #1: The default configuration when scanning with the membrane’s head coils.

System Type	Membrane Type	Imaging	Suggested actions
For all systems supporting Head coils	Exablate Neuro Patient Membrane with Coil 3.0T/1.5T	Scan with InSightec’s Head Coils	1. Make sure the MR connector(s) are connected to the MR
GE			2. Make sure the membrane’s head coils connectors are connected to their dedicated socket
			3. The default coil configuration in ‘System Settings (Treatment Mode)’ is ‘HEAD COIL’
			4. With GE MRI systems: Make sure the switch on the MR connector is ON (Blue led indicator ON)

Scenario #2: When head coil is on patient's head, and for some reason a scan with the Body coil is required.

NOTE: Scanning without the head coil may reduce image quality.

System Type	Membrane Type	Imaging	Suggested actions
For 3T systems only	Exablate Neuro Patient Membrane with Coil 3.0T	Scan with the MR integrated Body Coil	1. Keep MR connector connected the to the MR
3T GE			2. Keep the membrane's head coils connectors connected to their dedicated socket
			3. Switch coil configuration in 'System Settings (Treatment Mode)' to 'Body (Head Connected)'
			4. With GE MRI systems: Keep the switch on the MR connector ON (Blue led indicator ON)

Scenario #3: When treating with a patient membrane without an integrated head coil - Body coil will be used during the treatment.

System Type	Membrane Type	Imaging	Suggested actions
For 3T systems only	Exablate Neuro Patient Membrane without Coil	Scan with the MR integrated Body Coil	1. Connect the MR connector(s) to the MR
3T GE			2. Switch coil configuration in 'System Settings (Treatment Mode)' to 'BODY'
			3. With GE MRI systems: Switch the Blue led indicator on the MR Connector to OFF

Scenario #4 (troubleshooting): When the treatment started and encountered malfunction related to the head coil, an Error is shown on the workstation. The user needs to change and work with MR integrated Body coil.

NOTE: In the case of scenario #4, there is a risk of image artifact from the unused membrane's head coils. Perform only as troubleshooting if the head coils don't work toward treatment's end.

System Type	Membrane Type	Imaging	Suggested actions
For 3T systems only	Exablate Neuro Patient Membrane with Coil 3.0T	Scan with the MR integrated Body Coil	1. Keep MR connector connected the to the MR
3T GE			2. Keep the membrane's head coils connectors connected to their dedicated socket
			3. Switch coil configuration in 'System Settings (Treatment Mode)' to 'BODY'
			4. With GE MRI systems: Switch the Blue led indicator on the MR Connector to OFF

2. SAFETY

2.1. Exablate General Safety Considerations

Exablate Neuro was designed and manufactured to ensure maximum safety of operation. Maintain the system in strict compliance with the safety precautions, warnings, and operating instructions in this manual. The Exablate Neuro should be installed, maintained, and serviced by InSightec personnel, or other qualified personnel approved in writing by InSightec.

The Exablate Neuro, in whole or in part, should not be modified in any way without the prior written approval of InSightec.

The owner should ascertain that only fully qualified, properly trained and certified personnel according to InSightec training program, are authorized to operate this equipment.

It is important to keep this manual near the system. It should be studied and reviewed periodically by all authorized operators. However, InSightec makes no representation that the act of reading this operator's manual renders any user qualified to test, calibrate, or operate the system.

Unauthorized personnel should not be allowed access to the system.

If the system does not operate properly or fails to respond as expected to the controls as described in this manual, tend to the safety of the patient first, and then attend to the system.

As of July-22-2014, the Exablate Neuro System is designed to meet the Directive 2011/65/EU (Restrictions of Hazardous Substances (RoHS)).

Disposable Head Frame Screws are provided STERILE –Do not re-use or re-sterilize. Do not use if package is open or damaged.

System expected usable lifetime is 10 years. Upon lifetime elapsing please consult InSightec for further instructions.



NOTE:

Any serious incident that has occurred in relation to the device should be reported to InSightec and the competent authority of the Member State in which the user and/or patient is established.

N012

Use of Exablate System within MRI Environment



The following components are MR Conditional: Exablate 4000 Helmet System, Exablate 4000 Helmet System Storage and Transfer Cart, Adapter Baseplate and Front End (FE) Unit.



WARNING: W013
Do not attempt to use components other than the Exablate hardware, software, and system accessories, and the specified MR imaging system with the device.



WARNING: W014
The Exablate Helmet System Storage and Transfer Cart is meant to be operated within an MR environment. To avoid the risk of inadvertently bringing in magnetic articles into the MR room, Only the Exablate Neuro Helmet System may be placed on the cart. Do NOT use the cart to bring any other items (magnetic or otherwise) into the MR suite.



WARNING: W015
Operating heavy equipment may result in risks of injury. operate heavy equipment with care.



WARNING: W016
The Exablate Front End cabinet contains ferro-magnetic components and may not be moved too close to MR bore.
The Front End Unit must be tethered or fixated at all times, at a minimal distance defined by InSightec Service during installation.

2.1.1. Use of MR Equipment

Personnel operating the MR equipment must have a thorough understanding of the proper operation of the system.

Do not operate the MR equipment before reading the appropriate operator manuals and gaining a clear understanding of the operation of the system. If any part of the MR system's manual is not clear, contact the MR equipment's technical and/or clinical service personnel for clarification.



WARNING: W120
For the safety of the patients, the operating and technical personnel, all operating instructions, and particularly the safety instructions therein, must be strictly adhered to prior to any use of your Exablate device.
Verify MR is ready for diagnostic use according to applicable MR operator's manual.

**WARNING:**

W017

Auxiliary equipment (such as gating equipment, vital signs monitoring systems and RF coils) that has not been specifically tested and approved for use in the MR environment may result in burns or other injuries to the patient, as well as degraded image quality.

**CAUTION:**

C051

Scans may only be performed when the transducer is filled with water.

2.1.2. System Service

The Exablate system should be installed, maintained, and serviced by InSightec personnel, or other qualified personnel certified by InSightec.

Periodic maintenance should be performed according to InSightec's service standards by InSightec or by InSightec certified personnel.

**WARNING:**

W018

Cybersecurity and software updates are done as part of service periodical maintenance. If the System is NOT appropriately serviced and maintained, cybersecurity risks may increase over time and the System should not be used for clinical treatments.

**WARNING:**

W019

Updates should only be implemented by authorized InSightec technicians/personnel. Operators of Exablate should not accept or implement any updates.

**WARNING:**

W020

If the System is NOT appropriately serviced and maintained, it should not be used for clinical treatments.

**WARNING:**

W021

Do not attempt to repair the Exablate System in the event of system failure, malfunction or any evidence of damage to the components

**CAUTION:**

C007

The system should be discarded according to local regulations.

2.1.3. Safety Instructions



WARNING:

W022

Before using the Exablate Neuro system:

- Read and understand each of the following safety warnings.
- Refer to the safety information supplied with the MRI System.
- The Exablate Neuro system is Type B applied part.
- The system is properly grounded by design and by the installation process.
- It is important for the safety of the patient and operator to maintain proper system grounding. Connect the system as instructed, and do not disconnect any of the system's connection.



WARNING:

W023

Inspect all cables in need to be coupled before a treatment day, to ensure proper coupling and verify no tears or other visible damage is present.

2.1.4. System Setup

When setting up the system for treatment, make sure you adhere to the following cautions:

Ensure that the wheels of the FE and STC are locked when they are not being moved.

Use the designated handles only when maneuvering the FE or STC.



WARNING:

W024

Make sure all cables are laid out on the floor in a way that does not constitute a tripping hazard.



WARNING:

W025

In case of a mechanical shock on the transducer, as the following:

- Heavy object falling on the transducer surface (e.g. DQA Set Up Holder)
- Collision during Transducer positioner movement (e.g. Transducer internal surface pressed against the frame screw)
- Violent collision during movement.

Do not operate and contact InSightec for a conformity check.



WARNING:

W026

The Front End Unit should only be moved by two persons.

Make sure that the transducer is positioned on the HS according to the **Home Position** label.

To avoid the risk of pinching – hold both HS handles firmly when transferring the HS back and forth to the MRI Table.

**CAUTION:**

C008

Place extra care while handling/transferring the transducer. Rough handling may damage the transducer and affect its characteristics adversely.

When lifting the MRI Exablate Adapter Baseplate, and loading the water reservoir into the FE, practice proper lifting technique.

When handling the Main Cable, make use of the STC and/or the Detachable cable connector panel Plate to enable easier handling.

**CAUTION**

C009

Careless handling of the Detachable cable connector panel may result in injury. Please assure firm grip before use. Slide carefully into Connector panel holder and ensure it is firmly in place. Ensure cables are locked to connector panel before letting go. Carry carefully to avoid accidental release of cables.

2.1.5. System Stability

The Exablate system complies with Council EU MDR 2017/745, Annex I and 2006/42/EC Machinery standard regarding stability requirements.

Standard MR table operations and procedures are unchanged by the Exablate setup. Operations like **Table Up/Down**, **Cradle In/Out**, and **Patient Positioning** should be performed according to MR Manufacturer manual.

The system operator is obliged to meet and follow instructions addressing the stability of the system and safety precautions in a prompt and timely manner, as well as reducing the risks of collision of parts, falls, slipping and tripping.

2.2. Operator and Patient precautions

2.2.1. Operator Precautions

The Exablate Neuro system is designed to protect the patient and the operator from accidental exposure to ultrasound energy.

Review and follow all operator instructions included with the console.

The patient, operator and supporting clinical staff must each be able to freely activate a stop-sonication button at any time during the procedure. Pressing the stop-sonication button immediately ceases the sonication. Releasing the button enables the treatment to resume.

The Exablate Neuro console controls the connection between the ultrasound transducer and the rest of the system. The system power should be turned OFF before leaving the console to prevent undesired activation of the transducer.

The transducer surface is very delicate, therefore clean only with alcohol and a soft cloth and avoid contact any with sharp objects. When not in use, cover the transducer with the dedicated cover to avoid damage.

The **Sonication Power-ON** light in the magnet room indicates that the transducer is applying ultrasound energy. This light must be in clear view of the supporting clinical staff and the console operator. Never move the patient or place your hand near the transducer while the sonication power-ON light is illuminated.

It is hereby stated that no patients or operators are exposed to any hazardous material.

Changes to and modifications of this equipment by unauthorized personnel is NOT allowed.



WARNING

W108

For your safety and for protecting the patient, be aware that the Exablate Neuro system may contain **Natural Rubber Latex**, which may cause allergic reactions. Make sure that both the site's staff and the patient who may be in direct contact with the system parts are not allergic to natural rubber latex products, prior to every system use.

2.2.3. Patient Protection and precautions

For MRI safety, refer to the **Safety** section of the MR system operator's manual.

Ensure that the patient does not have any metallic implants, including but not limited to pacemakers and neuro-stimulators.

Metal objects are forbidden in the magnet room. Verify that there are no rings, clips, loose change, or any other metal object on the patient.



WARNING:

W027

Refer to safety guidelines issued by the MRI safety procedures and restrictions that may apply to the specific site.

- Do not leave a patient unattended in the magnet room.

The **Stop-Sonication button** must be given to all patients. Pressing the button immediately interrupts treatment. Four stop-sonication buttons are available on the system:

One is on the operator's console.

One is given to the patient.

One is located on the Front End Unit, to be controlled by a staff member in the treatment room.

One is on the Workstation GUI, enable during the sonication and interrupts only the sonication.

Instruct the patient to stop sonication when feeling pain or heat.

Supply the patient with hearing protection.

The patient is not always in view of the console operator. Be sure that medical personnel are in the magnet room during the procedure or that the patient is constantly in view and equipped with means to communicate distress.



WARNING:

W028

Cradle movement may cause patient injury. Verify that the patient's fingers and clothing (hospital gowns) are not in danger of being caught in the equipment during positioning or cradle motion.

Position the leg holder on the mattress or MR table.

Cover the mattresses and leg holder with sheets.

During treatment, frequently ask the patient if he/she is in any pain or discomfort.

To increase patient comfort and reduce the risk of patient hypothermia, body warmth should be maintained by accessories or systems provided by the site.

The use of any medication and/or imaging contrast should be applied only after considering possible effects of ultrasound energy absorption or thermal imaging.

The Exablate system creates heat in the target, which may cause thermal ablation based on temperature rise levels and duration. Thermal ablation prediction (referred to as thermal dose) is estimated using two dose levels of 17 and 240 cumulative equivalent minutes (CEM) at 43°C. Based on correlation with tissue damage seen on MR images, the two dose levels represent worst case scenario and size (i.e. low and high probability for) of thermal damage, respectively.

For each sonication, a spot overlay of those two dose levels (17 and 240 CEM) is presented on the WS screen. This overlay represents the location and bounding area of the spot and contributes to spot size estimation.

**WARNING:**

W029

Carefully examine the thermal images and the thermal dose contours after each sonication to avoid possible damage to unintended tissues.

**WARNING:**

W030

In case of abnormal system behavior, unexpected thermal maps, unexpected temperature rise, or inability to see or understand thermal maps, abort sonication and treatment immediately.

Cavitation refers to formation and collapse of bubbles (created from dissolved gas), which fills cavities that are created in low pressure regions. As a result, bio-effects may occur due to these bubbles and are dependent on the extent and type of cavitation. The Exablate has a built-in cavitation detector and a mechanism to automatically stop or adjust the power levels to avoid cavitation, which may cause unintended tissue damage.

**WARNING:**

W031

Prolonged immobilization may lead to increased risk of deep venous thrombosis (DVT) or pulmonary embolism (PE). In order to avoid this, the patient should be wearing **Thromboembolic Stockings (TEDs)**, also referred to as '**anti-embolism**' stockings through the entire procedure time in the MRI.

**WARNING:**

W032

Ensure that the patient has the Stop Sonication button and that he is able to operate it before initiating treatment. In the event of pain or patient motion, failure to do so may result in serious injury.

**WARNING:**

W033

The attending team must monitor the patient continuously during the procedure, taking into account the patient's medical history. Ensure monitoring means are available (e.g. patient monitor, audio/visual systems, pulse oximeter, supporting clinical staff in MR room etc.) Evaluate the patient's wellbeing after each sonication, and perform a full assessment at the end of the procedure, providing additional care accordingly.

**WARNING:**

W114

Due to the fixation of the head, the risk for asphyxiation in case of vomiting while the head is fixated to the treatment table, is increased.

Please ensure there is an available suction device primed and ready, and consider administering anti-emetic medication as needed.

**WARNING:**

W034

To avoid contamination of the water, verify fine shaving and no open cuts or lacerations on the area of the scalp above the Patient membrane.

**WARNING:**

W035

Failure to monitor the MR thermal maps during the procedure may result in unintended heating of non-targeted tissues, which may cause permanent injury. Operator must cancel/abort the procedure if MR thermometry data are not available.

**WARNING:**

W036

Ensure that only degassed water is used in the circulating area between the transducer and the Patients' skull to avoid air bubbles in the system which might result in skin burn.

**WARNING:**

W037

Prior to the delivery of each sonication throughout the treatment, the beam path should be evaluated to avoid scars or other irregularities in the skin which can cause pain or skin burns.

**WARNING:**

W038

Inadequate cooling time between sonications could lead to thermal build-up that may cause serious damage to normal tissues outside the targeted volume. The cooling time between sonications is automatically scaled according to the actual energy applied and sonication parameters and should not be decreased.

**WARNING:**

W039D

Due to shift compensation, a discrepancy between the RAS coordinates on the Exablate workstation and the MR Workstation may occur. During a treatment, always refer to the Exablate workstation coordinates (See Additional Cursor Coordinates Section).

**WARNING:**

W040

If the skull bone is heated significantly, tissue adjacent to the skull can also absorb heat and may be damaged. To prevent damage to this tissue, heating of the skull should be minimized – this is achieved both by circulating chilled water across the outer surface of the skull (avoid heating of outer skull-skin interface) and choosing target regions at a depth in the brain at least 2.5 cm from the skull (avoid heating of internal skull-tissue interface).

**WARNING:**

W041

Please note that the head average and local SAR displayed on the MR console are not accurate for the Exablate 4000 setup, due to the water and FUS transducer. Actual values can be as high as a factor of 4.

While the active cooling of the head compensates for higher average and local RF induced heating (a.k.a SAR), so that SAR limitation applied by the MR system are sufficient, apply extreme caution when using custom scan types to minimize risk of tissue heating

2.2.4. Patient Emergencies

Each Exablate Neuro site must develop appropriate patient emergency procedures.

All personnel who operate the system must study and practice patient emergency procedures.

If there is any sign of danger to the patient, proceed as follows:

1. Press the **Physician Stop Sonication** button on the workstation or the Front End unit to shut down the MR and the Exablate Neuro system. This will immediately stop any energy deposition and halt active MR scans.
2. If necessary, notify emergency personnel.
3. Bring the cradle outside of the bore, either by using the MRI scanners interface or if needed (e.g. in case of power loss) via the manual emergency release procedure as defined by the respective MRI diagnostic cradle manufacturer's emergency release procedures.
4. In emergency situations, it may become necessary to remove the patient from the room:

■ **For MRI Scanners with Fixed Tables:**

- Drain the water from the transducer and release the patient. Controlled water draining takes up to five minutes, but if necessary, the patient can be released in ~20 seconds without performing a drain, as most of the water will be contained in the designated basin below the transducer.
- In case of power loss with no urgency, Use the manual drain kit to drain water (See **MANUAL DRAIN KIT USE INSTRUCTIONS**)
(the Manual Drain procedure takes up to 15 minutes [see NOTE on next page]).
- To bring the patient out of the MRI Suite, keep a non-magnetic gurney inside the magnet room or a regular gurney outside of the magnet.
- Take the transducer as superiorly as possible and release the patient from the transducer interface as expediently as possible.

■ **For MRI Scanners with Detachable Tables:**

- Drain the water from the transducer and release the patient. Controlled water draining takes up to five minutes, but if necessary, the patient can be released in ~20 seconds without performing a drain, as most of the water will be contained in the designated basin below the HS.

- If time allows – Release the patient from the frame holder and transfer the Helmet System to the Storage and Transfer Cart. Otherwise detach the quick-coupler cables from the Front End and place on MR Table in a manner that will not inhibit table movement. Proceed to remove the patient table from the magnet room.
 - Since the patient table is not very maneuverable, consider keeping a non-magnetic gurney inside the magnet room or a regular gurney outside of the magnet.
5. Attend to the patient, following established hospital emergency protocols.



NOTE:

N013

The water system is drained and filled by the Water System Remote Controller or Water System Control Touchscreen. In case of complete power loss, or other malfunction of the automated water system, Emergency Drain Kit can be used to drain water from the transducer. Draining water from transducer may take up to 5 minutes. Review the **Manual Drain Kit Use instructions**.

In case of emergency, the patient can be released from the transducer without draining the water, in less than a minute. Most of the released water (up to 10 liters/2.65 US gallons) will be contained within the MR Baseplate, but risks of water spillage and a slippery floor exist.



WARNING:

W042

Water spilling may cause risks of MR damage, electrocution and slipping on wet floor.



WARNING:

W043

Life-support, resuscitation or any other equipment based on ferromagnetic components are not allowed in the magnet room (e.g. scissors, sharp tools near patient).

2.3. Water System Precautions

The water system is used to keep the skull cool during treatment. The water temperature is monitored by the system and is displayed on the Workstation screen and on the Water System Touchscreen as well.

During treatment, the operator must be aware of the following:

- Attend to any system alert or to a malfunction in the water system.
- Confirm that water circulation has restarted in between sonications and that the water temperature is adequate.

An improper seal between the patient's head and the Patient Membrane could result in a water leak in the MR bore. During water filling or draining (see Section **3.5, Operating the Water System**), confirm the following:

- The air ventilation tap is open.
- The operator must be next to the patient.
- Monitor any water leaks from the transducer.
- Watch for any excessive pressure in the Patient Membrane.

Prior to moving the cradle into the MR bore, always confirm:

- Confirm that the water drain below the transducer is empty and dry.
- Confirm that the air ventilation pore has been locked.

Water system indicator is located in the FUS application on the lower left corner (see Section **4.1.6, Status Bar**)

2.3.1. Water System Indicator & Circulation Controller

A blue light below the water system icon on the console indicates the state of the water system. When illuminated continuously the water circulation in the transducer's interface is active. The system will automatically cease circulation in case a system error is detected (e.g. excessive pressure, cable disconnected) or the temperature in the water interface is higher than the desired set point, when this happens, the water system indication will flash, and a detailed error description prompt will be displayed next to it



WARNING:

W044

The water in the transducer's interface may start getting warm because of a prolonged sonication sequence. Monitor the water temperature displayed on the workstation and water system control screens.

Follow the instructions displayed on the **Water System Control** screen to resolve the relevant error.

Make sure you first take the patient cradle out of the bore to confirm:

- No water leaks are visible.
- Water level in the transducer interface is nominal.
- Water pressure is nominal.
- No air is present in the transducer interface.
- Water hoses are not tangled or obstructed.
- Air ventilation pore is closed.

After resolving the issue and ensuring the Transducer interface is properly filled with water, RESET circulation by pressing the play Circulation button on the Workstation settings, the RESET icon on the Water System Control Screen, or the RESET button on the Water System Remote Controller.

If the problem persists, contact your InSightec Service representative for troubleshooting.

2.4. Head Coil Precautions

For full specifications pertaining to the use of Tc MRgFUS Head Coils see Section **2.4, Specifications**.

Compatibility



WARNING: W045
InSightec MRgFUS Coils are intended for use with InSightec Exablate 4000 Systems only! No modification of the coil is allowed!



WARNING: W046
Each Coil is compatible only with its designated and approved Exablate System Type and MR Scanner Models. Each Coil type is defined by its labels. Verify coil compatibility before connection. Never connect a coil that is not properly labeled! A coil tuned for different magnet strength may cause burns.

Coil Operating Safety

The MRgFUS Coil cannot be serviced on site. In case of coil fault or fault suspicion, replace the Patient Membrane with the Coil and contact your InSightec Service Representative for service and maintenance needs. Personnel should observe all warnings and cautions that appear in this manual.



WARNING: W047
No modification of the coil is allowed!

Patient Safety



WARNING: W048
Perform scans only when the coil is fully submerged in water (from the transducer side). Failure to comply may result in degraded image quality and patient burns.



WARNING: W049
Monitor the patient periodically. Stop the scan immediately if the patient reports any heating, burning or tingling sensations.

Patient safety and comfort should be the primary concern during the scanning procedure. Always follow proper safety, operating and maintenance procedures to ensure that the patient is not exposed to electrical or mechanical hazards that may potentially cause injury.

Equipment Safety

Personnel using the Coil must have appropriate training for proper connection, operation and handling of the Coil.

**WARNING:**

W050

Auxiliary equipment (such as gating equipment, vital signs monitoring systems and RF coils) that has not been specifically tested and approved for use in the MR environment may interfere with the proper operation of the Coil and degrade image quality

**CAUTION:**

C011

Prevent cables from forming loops. Looping will degrade scan performance of the coil through RF coupling. Keep the length of the cable in the bore to a minimum. Avoid bending the cable 180 degrees. Route the cable connecting to the MRI directly out of the bore, keeping it as straight as possible.

Electrical and Mechanical Safety**WARNING:**

W051

Before using the Coil:

- Visually check to ensure there is no external damage. Do not use the Coil if the housing or cable is broken.
- Verify that the Coil is properly connected. Electric shock may result if the coil is attached to the system during cleaning or when it is wet.

**CAUTION:**

C013

If the coil is found to be defective, replace coil. If attempting to replace the coil without displacing patient from table after planning images have been obtained, verify thoroughly that no patient movement has occurred and perform a full re-plan if necessary.

**WARNING:**

W052

3T MRI Only: It is also possible to switch from the Head Coil to the MRI's built in body coil in the 'System Settings' menu (See **10.5 System Settings (Treatment Mode)**)

If so - do not disconnect the Head Coil **OR** replace the membrane with a membrane without an integrated Head Coil.

2.5. Electromagnetic Compatibility (EMC) Precautions



CAUTION:

C015

- The Exablate Neuro system should not be used adjacent to or stacked with other equipment and, if adjacent or stacked use is necessary, the system should be observed to verify normal operation in the configuration in which it will be used.
- The Exablate Neuro system requires special precautions regarding electromagnetic compatibility (EMC) and must be installed and put into service according to the EMC information provided in Section **List of cables**.
- Be aware that portable and mobile RF communication equipment can affect the Exablate Neuro system.
- The Exablate Neuro should not be used adjacent to Portable RF readers. If use of adjacent RFID readers is necessary, InSightec service must be informed to verify normal operation in the configuration in which it will be used.



WARNING:

W053

Portable RF communications equipment (including peripherals such as antenna cables and external antennas) should be used no closer than 30 cm (12 inches) to any part of the Exablate 4000 System including cables specified by InSightec. Otherwise, degradation of the performance of this equipment could result.



NOTE:

N015

The EMISSIONS characteristics of this equipment make it suitable for use in industrial areas and hospitals. If it is used in a residential environment, this equipment might not offer adequate protection to radio-frequency communication services. The user might need to take mitigation measures, such as relocating or re-orienting the equipment.



WARNING:

W116

In case of system power loss due to AC inputs mains Voltage interruption, the system will shut down. Wait for a stable return of the AC power and restart the system to repeat the planning stage and resume the treatment. If the return of power is delayed, and you decide to abort the treatment, empty the water from the transducer using the Manual Drain Kit.



WARNING:

W119

In case of unexpected system behavior leading to an inability to safely control the system (such as display flickers, unresponsive keyboard/mouse, or consistently unresponsive UI) stop any ongoing sonications and do not proceed with the treatment before contacting your InSightec service representative.

2.5.1. Statement of the Exablate Neuro System Essential Performance:

The essential performances of the Exablate Neuro are:

Safety Monitoring:

- Monitors and verifies that sonication is executed as planned.
- Verifies that monitoring is running continuously.
- If failure of any of the above does NOT stop the sonication/halts the CSA (Control System Application), the system is NOT safe.

Spectrum Monitoring:

- Monitors the spectral signal that exists during the sonication.
- It may also be used to control the transducer's power output.
- Continuously verifies that the spectrum signal is below the allowed maximum.
- If the spectrum monitoring fails to control the signal to below the set limit, or to stop the sonication/halt the CSA if that it is above the limit, the system is NOT safe.

2.5.2. List of cables

Exablate4000 Connector / Cables list (1/2)			
No.	Name	Description	Location From- to
1.	Part of PCDU	380-400 / 480VAC 3 phase	Equipment room power - PCDU
2.	According to site installation	MRI safety	MRI PDU – PCDU
3.	CBL000346	Chiller mains	PCDU J401 to Chiller
4.	CBL2298-AA	RIOU to Chiller control	RIOU J501 – Chiller
5.	ASM001632	Chiller to FE Water pipes	Chiller – FE J805 “G”
6.	BUY000528	WS to MRI comm	WS- MRI (Ethernet Isolator)
7.	CBL000133 and BUY000528	WS to FUS comm	WS – ER Switch (Ethernet Isolator & cable)
8.	CBL000133 and BUY000528	Host to FUS comm	Console – ER Switch (Ethernet Isolator & cable)
9.	BUY000528	Host to Hospital	Console – Hospital (Ethernet Isolator)
10.	CBL14215	ER to Filter Box +15V	ER Upper HPS – Filter Box +15V
11.	CBL24215	ER to Filter Box -15V	ER Lower HPS – Filter Box -15V
12.	CBL34317	Filter Box to FE +15V	Filter Box +15V – Rear side FE J803 “G”

Exablate4000 Connector / Cables list (2/2)			
No.	Name	Description	Location From- to
13.	CBL044317	Filter Box to FE -15V	Filter Box -15V – Rear side FE J804 “E”
14.	CBL2220	EDU to Filter Box - signals	EDU J301 - Filter Box J703
15.	CBL2219	EDU to Filter Box - signals	RIOU J502 - Filter Box J702
16.	CBL2317	Filter Box to FE - signals	Filter Box – FE J801 “D”
17.	CBL002270	Receive unblank	MRI – EDU J312

2.5.3. Summary of EMC Test Results

IEC 60601-1-2 Edition 4.1 (2020).

Environment of intended uses:

Professional Healthcare Facility Environment

Test	Standard	Class/ Severity level	Test result
Emission (IEC/EN 60601-1-2 sections 7.1- 7.2)			
Conducted emission Freq. range:150 kHz - 30 MHz	CISPR 11 / EN 55011	Group 1 Class A on AC mains 3 phases	Complies
Radiated emission Freq. range: 30 – 6000P MHz	CISPR 11 / EN 55011	Group 1 Class A	Complies
Immunity (IEC/EN 60601-1-2 sections 8.9-8.11)			
Immunity from Electrostatic discharge (ESD)	IEC/EN 61000-4-2	8 kV contact discharges & 15 kV air discharges	Complies
Immunity from radiated electromagnetic fields	IEC/EN 61000-4-3	3.0 V/m; 80 MHz ÷ 2.7 GHz, 80% AM, 1 kHz	Complies
Immunity from Proximity field from wireless communications equipment	IEC/EN 61000-4-3	List of frequencies, from 9 V/m up to 28 V/m, PM (18 Hz or 217 Hz), FM 1 kHz	Complies
Immunity from Electrical Fast transient (EFT)	IEC/EN 61000-4-4	± 2 kV on AC main 3ph, DC, AC 1ph; ± 1 kV on signal cables Tr/Th – 5/50 ns, 100 kHz[Complies
Immunity from Surge	IEC/EN 61000-4-5	±2.0 CM /±1.0 kV DM on AC mains 3 ph, AC mains 1 ph Tr/Th – 1.2/50 (8/20) µs	Complies
Immunity from conducted disturbances induced by radio-frequency fields	IEC 61000-4-6	3.0 & 6.0 VRMS 0.15-80 MHz, 80% AM, 1 kHz on AC mains 3 ph, AC mains 1 ph & signal cables	Complies
Immunity from power frequency magnetic field	IEC/EN 61000-4-8	30 A/m @ 50 Hz & 60 Hz	Complies
Immunity from voltage dips, short interruptions and voltage variations	IEC/EN 61000-4-11	AC mains: 0% - 0.5 cycle & 1 cycle; 70% - 25/30 cycles; 0% - 250/300 cycles	Complies
Immunity to proximity magnetic fields in the frequency range 9 kHz to 13,56	Section 8.11 IEC/EN 61000-4-39	8 A/m 30kHz CW 65 A/m @134.2kHz PM 2.1kHz 50% 7.5 A/m @13.56MHz PM 50kHz 50%	Complies

This page is intentionally left blank for double-sided printing.

3. GETTING STARTED

3.1. System Set-Up



WARNING:

W054

The water system will reach its optimal operating conditions after approximately 30 minutes. Take this into consideration and turn ON the system as early as possible before the treatment to avoid downtime when the patient arrives.



NOTE:

N021

It is suggested to keep the *Handbook* accessible near the system for step-by-step checklists of setup and treatment procedures.



WARNING:

W056D

Visually inspect the Exablate Neuro system to:

- Verify the integrity of the Transducer, Front End and MR Table.
- Confirm that the connectors are properly fastened.
- Confirm that the table is properly docked.

Failure to follow these instructions may result in degraded system functionality.

3.1.1. Connect the Helmet System to the Front End

1. Unlock the STC wheels and position it near the Front End Unit.

In case there is difficulty accessing the FE with the STC, it is possible to carry the cables using the Detachable Cable Connector Panel and place it in the Connector Panel Holder on the FE.

2. Connect the Water Cable and the two uniquely labeled Quick Coupler Cables to the Front End.



CAUTION:

C016

Confirm that the quick coupler connectors are properly connected to the correspondingly labeled connection port.

- The connectors must be gently aligned into place before locking.
- Confirm the water cable is completely locked.



NOTE:

N022

Helmet System connection may also be performed after **System power ON** and **Water System Preparation**. In this case, press and release the Operator's Stop Sonication button to reset connections following the Helmet System connection.

3.1.2. System Power ON

1. The **Begin Log on** notice appears on the screen.
2. Remove all external media drives and/or DVD from the console.
3. Press **Ctrl+Alt+Del** to access the logon information dialog box.
4. Log in to FUS with your InSightec provided Username and Password (Windows® logon parameters are case sensitive); click **OK** to continue.



CAUTION:

C017D

Exablate Workstation username & password should not be printed or shared with anyone.

5. Select the relevant application from the application selection screen.
6. The Exablate Neuro disclaimer popup window opens; click **OK** to continue.

3.1.3. Prepare the Water System

1. Unload the Water Reservoir from the Water Reservoir Compartment in the Front End Unit and disconnect it via the quick-release cable.
2. Fill the reservoir with water up to the marking. Use *purified water complying with ISO3696 (1987) Grade 2, or ASTM (D1193-91) Type II, or NCCLS (1988) Type II or equivalent*, for the procedure, cleaning or DQA. Fresh Reverse Osmosis water can be use as well for Cleaning or DQA. Connect and return it to its designated compartment.
3. Set the water system state to **Degassing** from the Workstation screen's Settings menu or to **Prepare Water** from the Water System Control Touchscreen.
4. Press the **circulate** button on the water system remote controller or the 'play' symbol on the touchscreen to initiate degas circulation.
5. Indications of the Water System status will appear on the bottom of the screen in **Device Status** [(**Water system Status**, **Temperature** (°C), and **Dissolved Oxygen** (DO) levels [in PPM]] as well as on the Water System Control Touchscreen.



NOTE:

N023

You may proceed with System Set Up and preparation of the MR table while water preparation is ongoing.

3.1.4. Preparing the MR table

1. Bring the MR cradle all the way out of the MRI bore.
2. Remove any imaging coils or MRI Baseplates currently connected to the MRI Table.
3. Place the Exablate MR Baseplate on the MR Table and lock it in place (if applicable).
4. Ensure the Transducer is positioned within the Helmet System according to the **Home Position** label.
5. For DV GE MRI, undock the table and move it 20cm away from the MR or rotate the table 30° to enable access of the STC. Lock the table in place.
6. Unlock the STC and roll it towards the MR Bore while releasing the cable.
7. Place the STC perpendicularly to the MR Table, so that the blue markings are aligned.

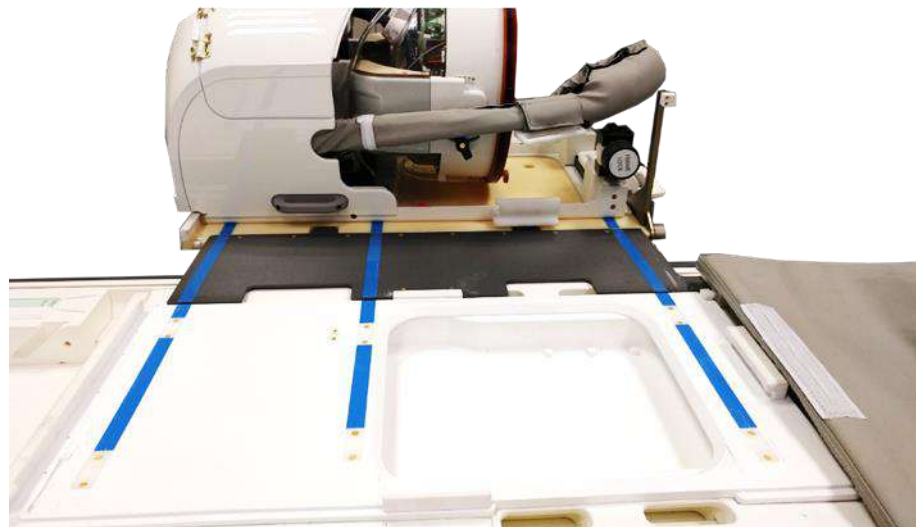

Figure 3-1: STC Bridge Coupled with MR Table for HS Transfer

8. Lock the STC's wheels in place.
9. Release and lower the Coupling Bridge. Ensure connection. Ensure the base lock is folded back to avoid collisions with the frame posts.



CAUTION:

To avoid damage to system components, make sure no cables are obstructing the path of the Helmet System to its position on the MR Table.

C019

10. Place one hand on the auxiliary handle and the other on the main handle. With your thumb against the 'lock' button, and while pressing the **Transducer Release Button**, slowly and firmly slide the Helmet System forward into place; a 'Clicking' sound denotes full coupling.

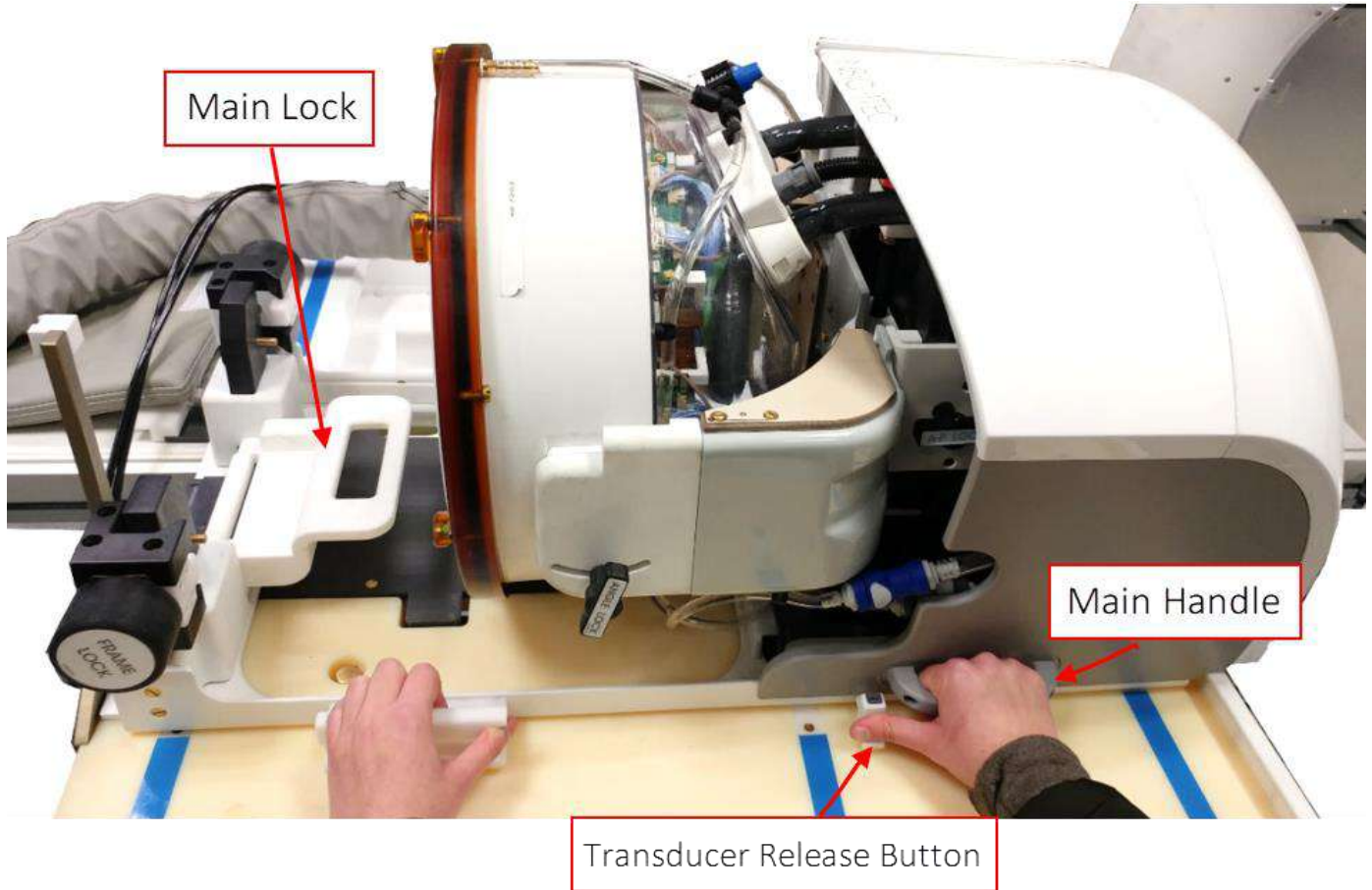

Figure 3-2: Transferring the HS to the MR Table

11. Lower the **Base Lock** to secure the Helmet System in place.
12. Connect the **MR Tracking and Head coil connector/s** into the MR Coil Socket on the MRI Table.
13. Connect the **Patient Stop Sonication Button** to its socket on the MR Table.
14. Unlock the STC and roll it into a location where it will not interfere with the treatment or potentially obstruct emergency procedures.
15. For DV GE MRI, dock the table back to the MRI.
16. Place mattresses and head **cushion** (optional) on the table and cover with sheet.

3.1.5. Verify System is Ready for Treatment

Confirm that the **device** and **MRI** status indicator are 'ready', and that the water system indicator on the operator console is indicating active circulation. If not, initiate circulation.



NOTE:

N020

For some **GE** scanners with newer SW versions (DV26 and up) you may need to press the 'External Host' button on the MR console and select 'ExAblate' from the drop-down menu to enable communication between the Exablate workstation and the MR scanner.



Figure 3-3: Selecting 'Exablate' as External Host (GE MR Interface)



NOTE:

N024

For **SIEMENS** systems, ensure the "remote connection" icon on the bottom of the MR workstation screen is in its enabled state:



If Disabled () click on it to enable communications.



WARNING:

W056D

Visually inspect the Exablate Neuro system to:

- Verify the integrity of the Transducer, Front End, Helmet System and MR Table.
- Confirm that the connectors are properly fastened.
- Confirm that the Exablate MR Baseplate and Helmet System are properly docked.

Failure to follow these instructions may result in improper system functionality.

3.1.6. Perform a DQA session

The DQA procedure should be conducted at the start of each day (prior the treatment), using the membrane intended for the treatment, to verify proper operation of the Exablate Neuro system.

Refer to the **Visualize Tractography**

After tracts are loaded successfully, a visualization controller will appear in the top-left corner of the main window.

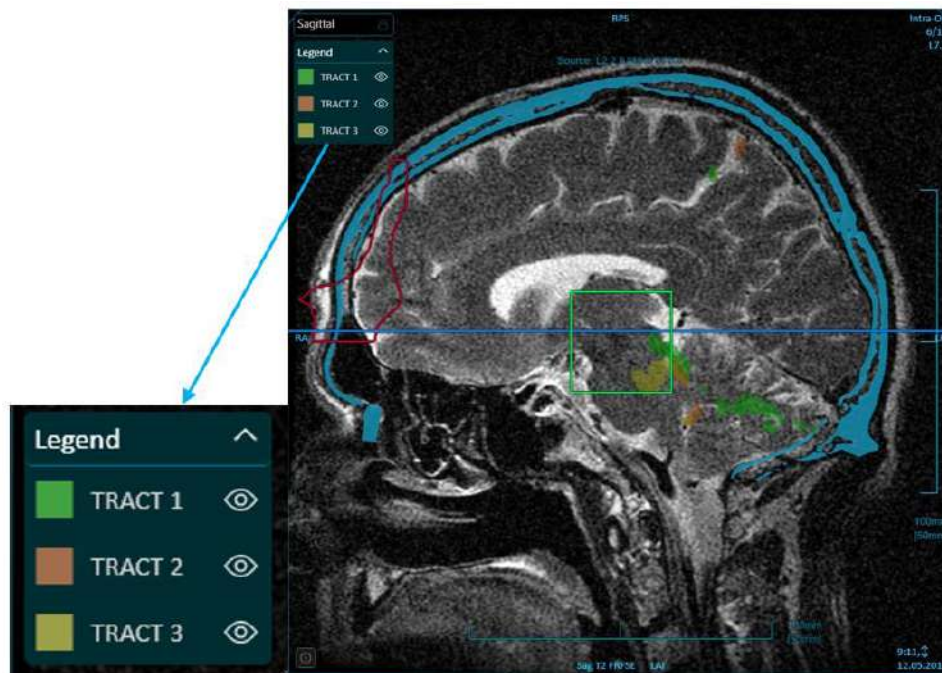

Figure 4-17: Tractography visualization and Legend

The tract drop-down menu acts as a controller, allowing users to select and rename their desired tract from the available options. This controller appears only when tracts have been loaded.

Each tract is assigned its unique color for distinction.

- To rename a tract, simply double-click on its name.
- To show or hide a specific tract overlay in the image window, click on the eye icon next to the name.

During the preplanning session, tract names will be saved.

DAILY QUALITY ASSURANCE (DQA) Chapter for instructions.

3.2. Remote connection

3.2.1. User remote connection

Remote connection enables connection between the Console and another computer.

- Remote connection usage is limited to pre-planning sessions, treatment viewing, and screening.
- Session will be logged off after 30 minutes of inactivity.
- In the event of a concurrent local login, a warning message shall appear, and the remote session will be terminated.

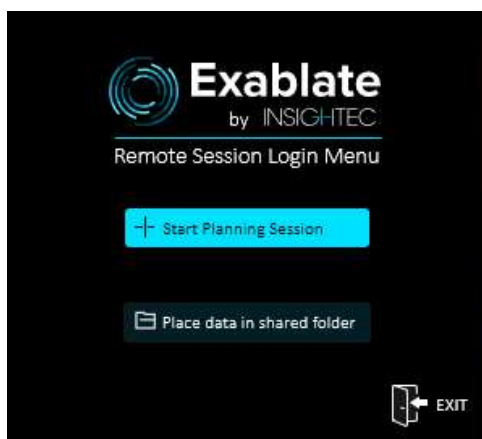

Figure 3-4: Remote Session Login Menu

From the login menu, click on “Place data in shared folder” to import needed Data as pre-operative images or CT to a shared folder. The shared folder will appear as "SHARED" in the various source and destination drop-downs.



CAUTION:

Data in the shared folder is periodically deleted every 24 hours.

C025

1. Click on “Start Planning Session” to arrive to the login menu.

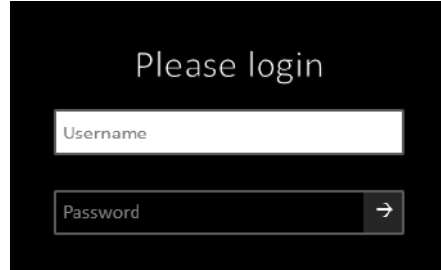

Please login

Username

Password →

Figure 3-5: Login Menu

2. Enter your Username and Password. You will be directed to the Application selection menu.

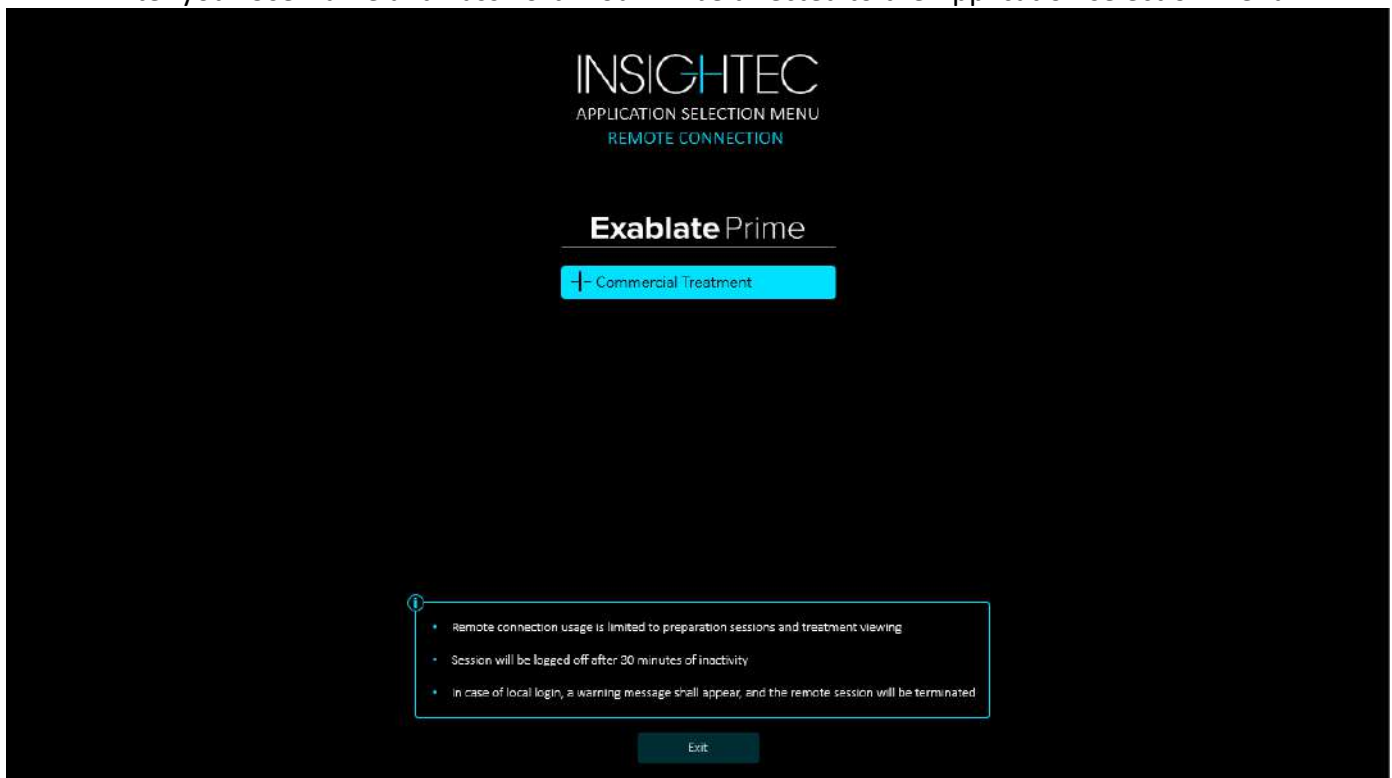

Figure 3-6: Application Selection Menu - Remote Connection

3. Click on “Commercial Treatment”

For Pre-Planning session, refer to the **PRE-PLANNING SESSION** Chapter.

For SDR Calculation, refer to the **SCREENING (SDR Calculation)** Chapter.

For reviewing previous treatments, refer to **DATA MANAGEMENT** Chapter.

3.2.2. Remote Support

During a treatment, there's an option for a remote connection to the session, including remote support. The names and number of individuals connecting to the session are displayed at the top of the screen, see example below:

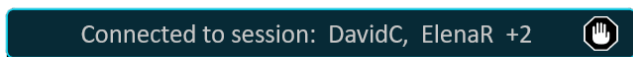

Users can opt to disable the remote connection by clicking the 'Stop' button adjacent to the listed names. To re-enable the connection, users need to return to the settings and activate the remote connection from there. See **section 10.2.2**.

3.3. Patient Positioning and Release

3.3.1. Accessories Required for frame fixation

1. Head Frame – head frame which allows for the fixation of the patient’s head to the bed.

For guidelines regarding the recommended operational use, cleaning, and maintenance procedures of the Head Frame, see Section **1.7, Exablate Head Frame Instructions for Use**.

2. Disposable Head Frame Screws for affixing the headframe to the patient’s skull.

Use a sachet of silicon sealant to ensure sealing between the membrane and transducer, if necessary.

3. Head Frame Positioning Straps are available to assist in frame placement.

3.3.2. Frame and Patient Membrane fixation

1. Ensure that the patient’s scalp is shaved well and that any scars or scalp lesions (i.e., eczema or psoriasis) are marked for avoidance by the treatment beam path to minimize heating/burning at the scalp.

2. Apply local anesthesia/numbing agents according to local protocol/regulation.

3. Affix the frame to the patient, as low as possible, while maintaining clear airway access.

4. Place the **Patient Membrane** (an elastic membrane which seals the transducer and enables acoustic interface between the transducer and the patient’s head) on the patient’s head over the Head Frame (See Section **1.7, Exablate Head Frame Instructions for Use**) and as low as possible in the right orientation.

- For Membranes without a Head Coil: screws/plastic side should face down towards the patient's feet.
- For Membranes with an integrated Head Coil: Ensure the Head Coil connectors are in a compatible position relative to the coil socket position of the transducer (See **Figure 3-7** and **Figure 3-8**).



NOTE:

Patient Membranes are “one size fits most.”

Some cutting may be required for abnormally large heads or sensitive patients.

N025

5. Confirm the tightness of the membrane to avoid discomfort or harm to the patient.

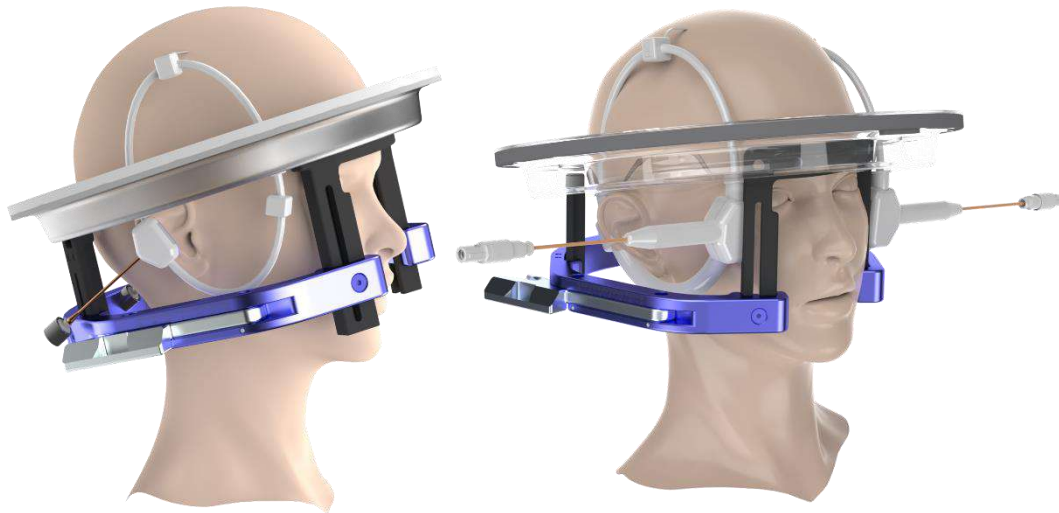

Figure 3-7: Examples of Patient Membrane Positions

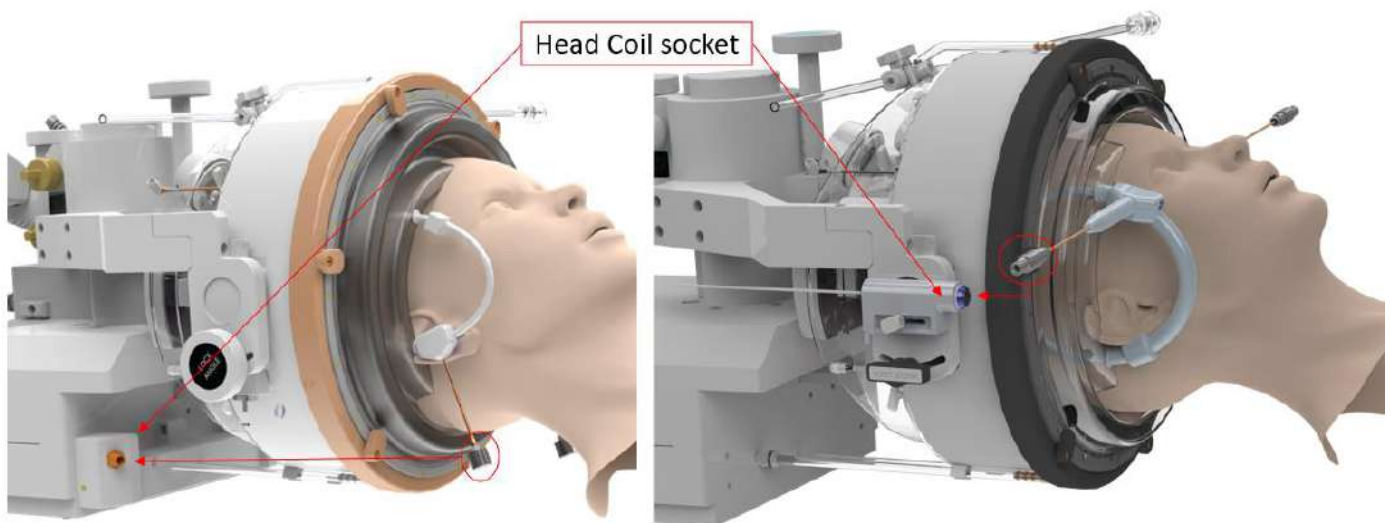

Figure 3-8: Examples of Patient Membrane dispositions according to Head Coil Socket Position.

3.3.3. Getting on the treatment Table



WARNING:

W058

Make sure the transducer is positioned as superiorly as possible to avoid patient injury when positioning on the table. Maintain eye contact while moving the transducer towards the patient to ensure clearance between the patient's head and the transducer.



CAUTION:

C050

The Exablate system does not support patient weight above 200kg. For maximum allowed patient weight, refer to the documentation of your respective MR model, taking into account that the total weight of the Exablate clinical setup may add up to 161 lbs. (73kg). Note that maximum allowed patient weight may vary according to the table state (e.g. docked, vertical movement etc.).

1. Assist the patient onto the table; lower the MR table and use stools if needed.
2. Instruct the patient to lie down in “Head-first supine” position and guide the Head Frame into the **Base Plate Attachment**; lock it in place.
3. Use a **Cushion** or the **Patient Leg Holder** on the MR table as needed to improve patient comfort (optional).
4. Ensure that the transducer's front-ring seal (O-ring) is secured tightly in place. If loose, replace with a spare O-ring and contact your InSightec representatives to order a new replacement.
5. Move the transducer to the treatment position. **Maintain eye contact with the patient's head and the transducer to avoid hitting the patient with the transducer.**



CAUTION:

C041

When moving the transducer, always ensure the patient's head or headframe pins do not touch the transducer. In case you feel irregular resistance while moving the transducer, immediately stop and examine the set-up.

6. Couple the **Patient Membrane** with the transducer. Confirm that all latches are fastened in place and that the patient does not feel any pain or discomfort.
7. If applicable: connect Head Coil (see **Figure 3-8**).



NOTE:

N027

Head Coil Connectors of all Head Coils are adjustable in the S-I direction. See section Head Coil Specifications for further explanation.

8. Secure the patient on the treatment table. Lock the head frame into place.
9. Fit the patient with earplugs.

10. Fill the transducer with water:

- Open the Transducer Ventilation Tap.
- Press and hold down the **Fill** button on the Water System Remote Control or on the **Water System Control** screen (see Section 3.5, **Operating the Water System**).
- Watch for any water leaks and hold the **Fill** button until the transducer is full. The membrane should feel tight, and there should be no areas where the membrane is concave past the transducer's rim.
- Close the Transducer Ventilation Tap.
- Press the red **Pressure Release Valve** to release excess air from the tubing. Press **Fill** to add more water if needed (without opening the ventilation tap).



WARNING:

W059

The transducer interface must be filled completely with water without air bubbles to provide adequate acoustic coupling. Pay strict attention that no air has entered the transducer interface and that it is filled with water continuously during the treatment. Incorrect coupling may cause reduced focal zone temperatures, defocusing and misalignment of the focal spot, and/or severe damage to system components.

After the patient is lying comfortably on the patient table, insulate the patient from the MR scanner with appropriate thermal-resistant pads to prevent potential RF burns. Place the pads along the patient's sides to insulate the patient from the scanner walls. Patients in danger of touching the scanner ceiling require thermal-resistant pads for the back and buttocks.

Verify that an open space of more than 0.5" (1.25 cm) exists between all system components and the patient to the sides and top of the scanner.



WARNING:

W060

Pay strict attention to the top part of the transducer and ensure proper clearance from the top of the magnet bore. When moving transducer towards the patient, maintain eye contact at all times to ensure clearance between the patient and transducer.

Ensure that the patient's gown or any cable does not hinder and block the movement of the table mechanism as it goes in and out of the scanner.

Ensure that patient's body is strapped to the patient table to avoid an accidental fall of the patient and/or any objects from the patient table.



Figure 3-9: Subject Positioned on MR table with Leg Holder (for illustration purposes only)

3.3.4. Landmark management and recovery

In case of accidental landmark (AKA iso-center\Lightvisor position) loss or change, the system shall notify the user that the landmark has changed. The following methods are available for landmark recovery:

- Placing dedicated (or other) sticker labels on the MR table and cradle when landmarking provides a physical marker to which the landmark may be aligned and re-set.
- On supporting systems: the informative system pop-up message may include an exact value to which the landmark may be set (corresponding to value on MR scanner's dedicated screens)
- PHILIPS ONLY: as there is no place on the table to place any stickers, a dedicated accessory is provided. Latch one part of it to the rib of the table, and slide the other into the PHILIPS MR Cradle plate's grooves (see image below). Align the moving part to the stationary one when setting the Lightvisor, and lock it in place.
- PHILIPS ONLY: Settings screen displays the cradles current distance from landmark & scan plane.

Note that some of the above do not apply to all system types.



Figure 3-26: Philips Landmark Accessory

3.3.5. Mechanical Positioning of the Transducer



Figure 3-10: Mechanical Positioning Unit. Levers (Left), Locks (Right).

The transducer’s location is set by a mechanical positioning unit which is manually adjusted by the operator. Manual movement of the transducer enables both easier patient placement as well as the alignment of the transducer’s Natural Focal Point (Transducer Focus) with the anatomical target.

The transducer's location can be adjusted along all three main MR axes:

Right-Left, Anterior-Posterior, and Superior-Inferior. The angle can also be changed via rotation about the R-L axis.

Note the convention: R+, L- A+, P S+, I-.

To move the transducer along a specific axis, first unlock the desired Axis lock by turning it counterclockwise. Then use the dedicated levers to turn the positioner in the desired direction, as indicated by the value on the positioner.



Figure 3-11: A-P Positioner Lever

Once the transducer reaches the desired location on each of the axes, re-lock each axis lock by turning them clockwise to eliminate transducer movements during the treatment.

To adjust the angle, unlock the angle lock, adjust the angle manually, and re-lock.

3.3.6. Patient Release

At the end of the treatment release the patient as follows:

1. Bring the cradle out of the MR bore.
2. Drain the water from the transducer:
 - Open the **Transducer Ventilation Tap**.
 - Press and hold down the **Drain** button on the **Water System Remote Control** or Water system screen until the transducer is completely empty.
3. Disconnect the head-coil connectors from the transducer (if applicable)
4. Unfasten the latches and disconnect the **Patient Membrane** from the transducer.
(Conversely, the membrane may first be gently removed from the patient's head at this point)
5. Move the transducer **Superiorly**, as far away from the patient as possible.
6. Release the **Head Frame** from the **Base Plate Attachment**.
7. Instruct and guide the patient to sit up.
8. Remove the **Patient Membrane** from the patient's head (or transducer).



Figure 3-12: 1.5T TcMRgFUS Head Coil Connector Plug and Socket (For illustration only)

3.4. Application Selection Menu

Ensure that the Exablate Neuro system is turned ON and logged into.

Optional: The Exablate application selection window will appear for Exablate systems with more than one application capability. Click the button of the desired application to enter the **Main Screen** and start the treatment.

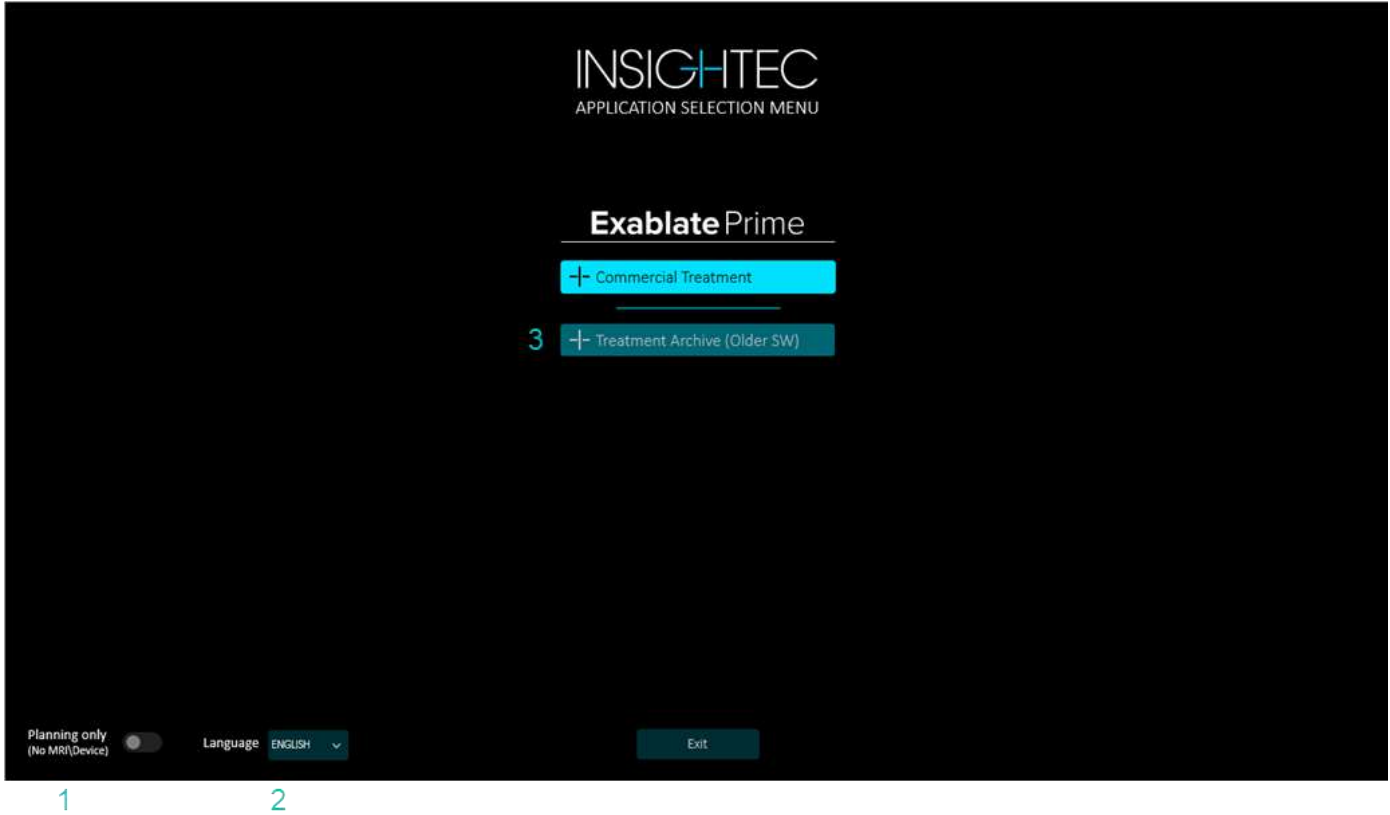

Figure 3-13: Select Application Screen (For illustration only)

No.	Name	Description
1.	Planning only (No MRI Device) Toggle button	Press this toggle button to switch to a planning mode only environment. limited to Pre-Planning sessions, treatment viewing, and screening. The same conditions as “Remote connection” are applied. See Section 3.2, Remote connection.
2.	Language (If applicable)	When available, the language selection drop down menu enables setting the software UI language.
3.	Treatment Archive (older SW) Application	If your site has a database of Exablate 4000 treatments performed using previous Exablate software versions, press this button to launch a standalone viewing mode for those treatments.

After selecting the application, the **Main screen** will appear:

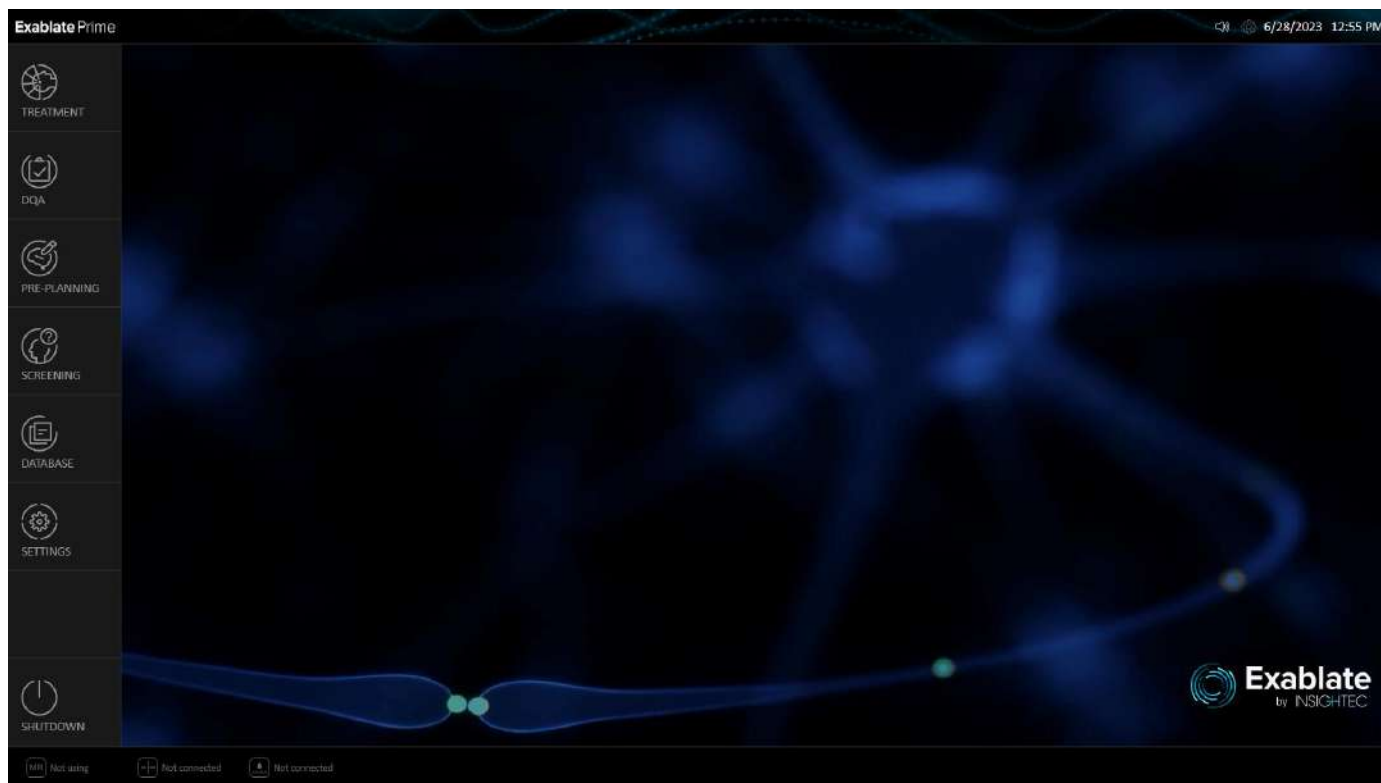

Figure 3-14: Main Screen

The **Main screen** displays the **Treatment, DQA, Screening, Pre-Planning, Database, Settings, and Shutdown** buttons. Each option is described in its dedicated chapter.

Verify that the buttons in the Status Bar are “ready” or “idle” and proceed to patient positioning. When the buttons are in another status, follow the system's on-screen instructions. See section **4.1.6, Status Bar**.



NOTE:

N028

To review previous treatments, press on the **Database** tab and refer to the relevant chapter.



CAUTION:

C048

In case the display becomes unresponsive, try to troubleshoot by pressing the "win" key and logging out and in again. (winkey+L or Alt+Ctrl+Delete)



NOTE:

N097

To Lock the screen (e.g. if leaving the room) press winkey+L or Alt+Ctrl+Delete

3.4.1. Treatment Start

Pressing the **Treatment Tab** button activates the application-specific treatment.



Prepare a Planning Session

Press this button to begin the **Pre-Planning** session or to open an existing session that was saved (see the **PRE-PLANNING SESSION** Chapter).



Start Treatment

Press this button to begin a treatment session (see the **TREATMENT: THERAPY STAGE** Chapter.)

3.4.2. Treatment Mode Entrance Tab

Before beginning a treatment, the user must enter data regarding treatment-specific target characteristics (see **Figure 3-15**).

The screenshot shows a mobile application interface for entering treatment parameters. It includes the following fields and controls:

- 1** Treating Physician: Dr. Demo (dropdown)
- 2** Indication: Essential Tremor (dropdown)
- 3** Intended Target Location: Right (dropdown) and VIM (dropdown)
- 4** Preference Profile: Default (dropdown)
- 5** Active Coil Type: HEAD (radio button)
- 6** Current Exam Information: Refresh icon
- Patient Name: Demo_WSSFN (checked)
- Patient ID: BR007-62-240708A (checked)
- Exam#: 277 (checked)
- 7** Patient Membrane Code: BCAE (dropdown) with a plus icon
- 1/1 Uses left (checked) with a gear icon
- 8** Start Treatment (button)

Figure 3-15: Treatment Mode Entrance Tab

No.	Name	Description
1.	Treating physician	Chose the physician’s name from the drop-down menu. See Section 10.4, Entrance Screen Lists to Edit before treatment start.
2.	Indication	Chose the Indication from the drop-down menu. See Section 10.4, Entrance Screen Lists to Edit before treatment start.
3.	Intended Target Location	Chose the Intended Target Location from the drop-down menu. See Section 10.4, Entrance Screen Lists to Edit before treatment start.
4.	Preference Profile	Chose the Preference Profile from the drop-down menu. See Section 10.3, Profile to Edit before treatment start.
5.	Active coil type	Display active coil type as selected in System Settings screen.
6.	Current Exam Information	After opening a new exam on the MRI, the Patient Name, Patient ID and Exam number will appear on the ‘Current Exam Information’ part of the screen. Make sure the information corresponds to the opened exam before starting the treatment. Press refresh to re-query the MR.
7.	Patient Membrane Code Area	Patient membrane code area for monitoring the patient membrane use. See section 3.4.3, Patient Membrane Code for more information. Note that only codes consistent with the active coil type will be accepted.
8.	Start Treatment	Once all fields are complete (mandatory before starting a treatment), press this button to start a new treatment.

3.4.3. Patient Membrane Code

Each treatment membrane has a unique code located on the membrane box and, if applicable, on the membrane coil loop.

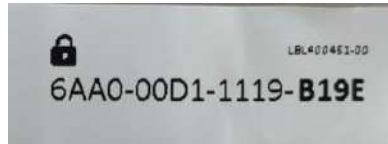

Figure 3-16: Example of membrane code

Membranes are designed for single use only. For the safety of the patient, the system will not allow additional treatments to be initiated with a membrane code once it has been used once, or its expiry date has passed, or in case of a membrane\system configuration mismatch.

An active membrane code is required before beginning a treatment.

To see active membrane code information during the treatment, refer to Section 10.5, **System Settings (Treatment Mode)**.

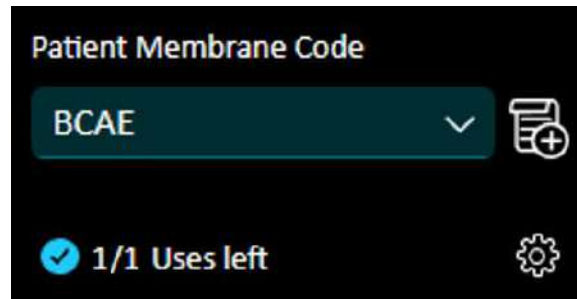



Figure 3-17: Patient Membrane Code Area



NOTE:

N026

Membrane codes that have been used once will no longer appear on the list. A use is deducted after a sonication is performed.

- The drop-down menu shows the 4 last digits of unused membrane, codes previously added to the system.
To view the complete membrane code, refer to the dedicated sub-section in Section 10.5, **System Settings (Treatment Mode)**).
- To add a new membrane code, press the  button on the right and type the Membrane Code in the appropriate field, then press Apply.

In case of an extenuating circumstance where there is no valid code for the treatment, press the settings icon:  to activate the Manual Override mode. Follow the instructions on the screen.

3.4.4. Begin Treatment Flow

After positioning the patient, the treatment procedure can then be initiated from the console (see Section 3.4.2, **Treatment Mode Entrance Tab**).

1. Chose the user name from the drop-down menu. The name may consist of letters only (no numbers or symbols).
2. Chose the Indication.
3. Chose the intended Target Location.
4. Chose the preference Profile.

Each of the above fields can be modified. Refer to the relevant section in the **SETTINGS** Chapter.

The chosen data above is predefined. To add or edit, refer to the **SETTINGS** Chapter.

5. Open a new exam on the MR console. Check that the right information is displayed in the “Current exam information section”. Refresh if needed.
6. Chose the membrane code corresponding to the membrane used during the treatment.

If using a new membrane, enter the new code to the list by pressing the add button.

The uses left will appear on the screen.

7. Press “Start treatment” to start a treatment.

3.5. Operating the Water System

The water system is a semi-closed water circulation loop used for filling and draining the transducer-water interface as well as preparing and circulating cool, degassed water during treatments. Various modes, states, and parameters of the Water System can be controlled through various ways:

1. The Water System Control screen on the Front End Unit (see Section **3.5.2, Water System Touchscreens**).
2. The Workstation Settings Section. Within this section the user can set the Water System stage to Preparation (degassing), treatment Circulation, or Cleaning. They can also define the target temperature of the chiller and turn the water cooling ON/OFF. For more details, see the **System** Section in the **SETTINGS** Chapter.

For details regarding the Water System cleaning and maintenance, review the **CLEANING AND DISINFECTION** Chapter.



CAUTION:

C018

If the blue water system control LED on the Operator Console (or the light on the remote) start flashing, there is a malfunction in the system. The error will be shown on the FE or workstation screen (status bar). See Water System Error Handling Section for more details.

3.5.1. Water System Remote Controller

The Water System Remote Controller is connected to the Front End Unit via a cord. The Remote allows the user to perform the following operation: drain water, fill water, pause/resume & reset.



Figure 3-18: Water System Remote Controller

When circulating, the RESET/CIRC button is lit (see **Figure 3-19**).



Figure 3-19: Water System Remote Controller States: Idle (Left) and While Circulation Is Active (Right)

The LED on the top of the Remote Controller indicates the state of the water system LED on the Operator Console (i.e., when the water system is online, the LED it is lit). The LED will start blinking if there is a Water System error.

3.5.2. Water System Touchscreens

3.5.2.1. Water System Main Screen

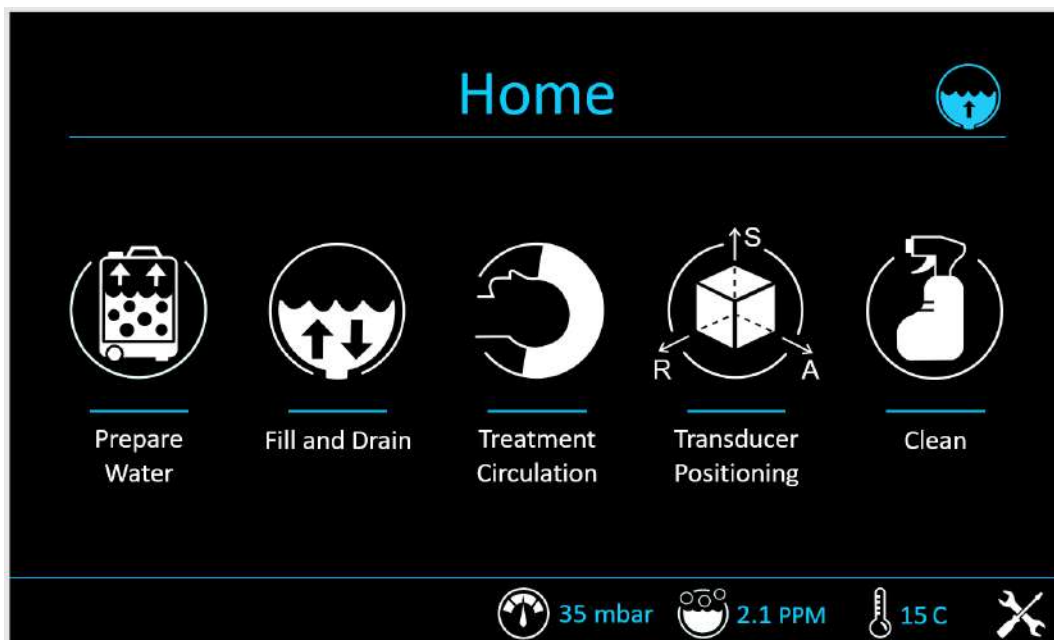

















Figure 3-20: Water System Operating Modes

Image	Name	Description
	Prepare Water button	This button opens the Prepare Water screen (see section 3.5.2.3, Prepare Water Mode (Degas)).
	Fill and Drain button	This button opens the Fill and Drain screen (see section 3.5.2.4, Fill/Drain Mode).
	Treatment Circulation button	This button opens the Fill and Drain screen (see section 3.5.2.5, Treatment Circulation Mode).
	Transducer Positioning button	This button opens the Transducer Positioning screen (see section 3.5.2.6, Transducer Positioning Mode).
	Clean button	This button opens the clean screen (see section 3.5.2.7 Clean Mode (Post Treatment)).
	Pressure indicator	Indicates the pressure inside the transducer.
	Dissolved Oxygen indicator	Indicates the dissolved oxygen in the water.
	Water Temperature Indicator	Indicates the water temperature.
	Utilities and Settings button	This button opens the settings screen (See Section 3.5.2.8 Water System Utilities and Settings).

The Exablate 4000 Water System has several operation modes: **Prepare Water (Degas)**, **Fill and Drain**, **Treatment circulation**, **Transducer Positioning** and **Clean**.

The user can cycle between the operating modes via the **Water System Control** screen or from the **Settings Menu** on the Operator Console.

3.5.2.2. Touchscreen Icons

	Home	Return to the Home screen.
	Drain	While the button is pressed, the system will drain water from the Transducer to the Reservoir. The Drain function is available throughout the treatment, at all Water System Control Touchscreen screens.
	Fill	While the button is pressed, the system will fill the transducer with water from the Reservoir. Filling is available from the various mode screens.
	Circulate	Starts water circulation in the Reservoir or Transducer (NOTE: Depending on selected mode).
	Pause Circulation	Pauses water circulation.
	Reset	Resets Water System Error (NOTE: Does not automatically restart circulation).
	FE Drain	Drains residual water from Front End

3.5.2.3. Prepare Water Mode (Degas)

The water within the Water Reservoir is cooled down and air bubbles are filtered out.

Preparing the water from 25°C to 15°C and from a PPM level of 5.0 PPM to 1.0 PPM takes up to 30 minutes.



Figure 3-21: Degas Mode Screens



CAUTION:

To avoid introducing large amounts of air into the system, only perform degassing when the reservoir is filled with water (up to the relevant marking on the Water Reservoir).

C021

3.5.2.4. Fill/Drain Mode

Fill/Drain Mode are to be used for the following tasks:

- Filling or draining the transducer (Open valve)
- Adjusting water volume in transducer (Closed valve)
- Draining residual water from the Front End (Extra Drain)

At the end of each treatment day, if no cleaning is performed, drain residual water from the Front End.

Remove the membrane and set the air-valve to closed position.

3.5.2.5. Treatment Circulation Mode

Treatment circulation mode is to be used when the transducer is sealed and filled with water (e.g., during treatment or a DQA).

Water is circulated around the patient’s skull to facilitate and expedite cooling of the skull after performing treatment sonications.

Treatment circulation also maintains the water temperature and degassing level of the water in the transducer.

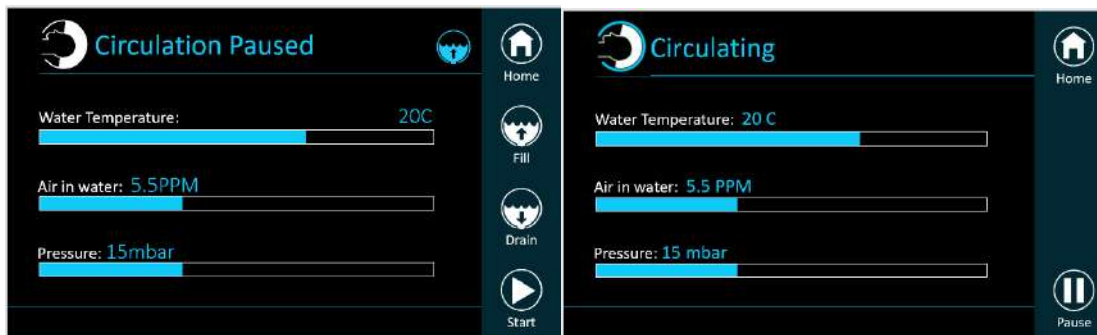

Figure 3-22: Circulating Screens

3.5.2.6. Transducer Positioning Mode

During the Planning stage, after determining the desired **Target location**, the distance between the transducer’s natural focus and the target is shown on the FE system GUI (see **Figure 3-23**). The user may then adjust the transducer manually.

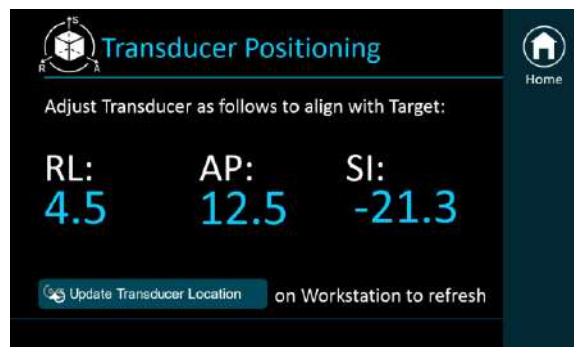

Figure 3-23: Transducer positioning screen

3.5.2.7. Clean Mode (Post Treatment)

Once the Helmet System has been transferred from the MR table to the cart, a cleaning procedure is to be performed to clean, disinfect, and drain the Transducer as well as the entire Water System Piping and Reservoir.

The procedure must be performed once five patients have been treated, or in case over seven days have passed without cleaning following a treatment. A general recommendation would be to perform the cleaning cycle at the end of every treatment day.

For a detailed description of the procedure, see the **CLEANING AND DISINFECTION** Chapter.

Once the cleaning procedure is complete, the operator may proceed to **System Shutdown**.

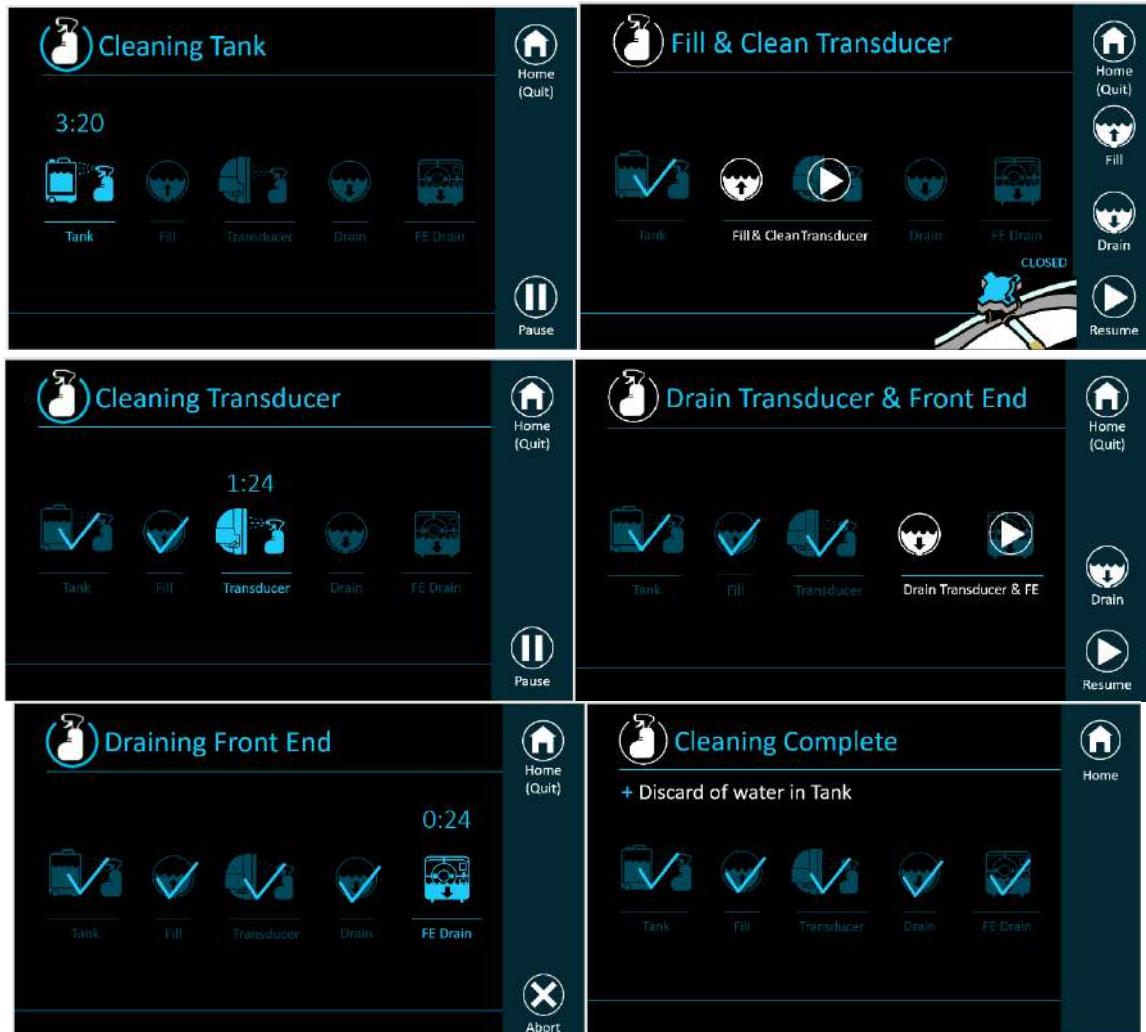

Figure 3-24: Clean Mode Screen Sequence

3.5.2.8. Water System Utilities and Settings

The Utilities and Settings screen presents the following water system parameters in real time:

System Status, Water Temperature, DO in Water, Air Pressure, Water Pressure, Main flow, UV1, UV2, and Blade temperature.

It is possible to Activate/de-activate the **Manual Override Mode** by pressing the following button:  (See Section 3.5.4, **Manual Override mode**).

3.5.3. Water System Error Handling

Water System Errors are indicated by the following:

- A flashing of the blue water system control LED on the Operator Console.
- A flashing of the blue LED on the Water System Remote Controller.
- The Device status message on the WS screen states: “Error”.
- A detailed error description with mitigation steps is displayed on the Water System Control Touchscreen.

The system will automatically cease circulation if a system error is detected (e.g. excessive pressure, cable disconnected) or the temperature in the water interface is higher than the desired set point. Some errors (e.g. low water pressure) will not lead to an alert prior to sonication, while others (e.g. water temperature exceeds defined limit) will trigger a prompt which the user can interact with before sonicating.

In the event of an error, the user must perform actions to mitigate the error. Follow the instructions displayed on the Water System Control Screen to resolve the relevant error.

Make sure you first take the patient cradle out of the bore to confirm:

- No water leaks are visible
- Water level in the transducer interface is normal
- Water pressure is normal
- No air is present in the transducer interface
- Water hoses are not tangled or obstructed
- Air valve is closed

After resolving the issue and ensuring the Transducer interface is properly filled with water, reset circulation by pressing the **Circulation** button on the controller, the **RESET** icon on the **Water System Control** screen, the **RESET** button on the WS, or the **RESET** button on the Water System Remote Controller.

If the problem persists, contact InSightec Service representative for troubleshooting.

3.5.4. Manual Override mode

In certain extreme cases the activation of manual override mode is necessary. Activating manual override mode disables automatic monitoring, including:

- Pressure and Vacuum limits
- Error monitoring

Activation and de-activation of the override mode is done via the Utilities and Settings screen.



Enter Manual Override Mode button activation.

After activation a “**MANUAL OVERRIDE MODE ACTIVE**” text will appear on the water system screens.



Exit Manual Override Mode button activation.



CAUTION:

C045

Activating manual override mode disables automatic water system monitoring. Pay close attention to the water system behavior. Prolonged unaddressed errors may result in system damage and reduced performance.

3.5.5. Water leak mitigation

Rarely, the Treatment membrane may be accidentally punctured, resulting in a water leak. Note that if the puncture is minor and its location poses no harm to the patient, it may be possible to proceed with the treatment. In the case of a moderate leak, use the supplied Leak Mitigation Clamp to pinch the membrane and stop the leak (See **Figure 3-25**).

In case of a significant tear, discard the membrane and restart the treatment using a new membrane.



CAUTION:

C010

If a membrane has been damaged, discard it following the treatment.



WARNING:

W111

The Leak Mitigation Clamp supplied as part of Exablate treatment kits is verified for use in an MR environment.

The use of unauthorized clamps may result in injury or imaging artifacts.



Figure 3-25: Example of Leak Mitigation Clamp Usage

3.6. Shutdown

To shut the system down, proceed as follows:

1. Press the shutdown button on the system main screen, see Section **4.1.5 End Treatment**.
2. The system responds with the **Shutdown Confirmation** message.
3. Press **Shutdown** to continue; the automatic shutdown procedure will be initiated. This takes several minutes.
4. Disconnect the coupler cables from the Front End Unit **only** when the console has fully powered down, and the power-ON light has turned off:
 - Unlock the quick-coupler lever and gently slide the cable's quick-coupler out.
 - Pull the white handle towards you and slide the hose cable's quick-coupler out.
5. To prevent damage to the transducer at the end of the working day, verify that the transducer is empty and dry, and attach the transducer cover.



CAUTION:

C020

Do not leave the transducer filled with water unattended or for an extended period of time. Make sure remaining water is discarded following a treatment day.

6. When not in use, cover the patient table with the protective table cover.

After long periods of inactivity there is an automatic log-off and shutdown of the system.

This page is intentionally left blank for double-sided printing.

4. TOOLS & OVERLAYS

This chapter describes the elements which appear on the **Main Screen** throughout the treatment cycle.

4.1. Treatment Screen - Overview

This section describes the layout of the treatment screen. Different tools are available to the operator depending on the stage of the treatment.



Figure 4-1: Treatment Stage Screens

No.	Name	Description
1.	Main Image Window	Displays one of the chosen orientations of the images. See Section 4.1.3, Image viewer window
2.	Secondary Top Image Window	One of two small image windows. Displays one of the chosen orientations of the images. See Section 4.1.3, Image viewer window
3.	Secondary Bottom Image Window	One of two small image windows. Displays one of the chosen orientations of the images. See Section 4.1.3, Image viewer window
4.	Image Tool Bar	The Tool Bar includes various tools for manipulating the image display. The tools are available according to the stage. See Section 4.2, Tool Bar .
5.	Sub-Stage Toolbox	The Sub-Stage Toolbox includes the relevant tools for each stage. Each Sub-stage toolbox is detailed in its relevant section in the different treatment stages.
6.	Navigation Bar	The navigation bar enables navigation through the different substages of the treatment when possible. See section 4.1.1, Navigation Bar .
7.	Thumbnail Bar	The Image Thumbnail bar presents a list of loaded and scanned image series in the WS. The displayed list may vary among sub-stages by displaying only the relevant series for that sub-stage/stage. The thumbnail bar is used for transferring series to the different windows, via drag-and-drop or by other mechanisms like right-clicking with the mouse. See section 4.1.2, Image Thumbnail Bar .
8.	Wait Message Area	In this area warning messages and treatment/progress status information is displayed to the operator.
9.	Image Retrieval Dialog Button	This button opens the Image Retrieval Dialog screen which allows the operator to import Pre-operative and Intra-Operative (MR/CT) images from a variety of sources. For further details refer to Section 4.3, Image Retrieval Dialog .
10.	Title Bar	The Title Bar presents general information and functionality (Date, Time, Settings and Sound), the MRI Scan Progress Bar, as well as the SW-based stop sonication button. See the Section 4.1.4, Title Bar .
11.	End Treatment	Press this button to Exit the current treatment. See the Section 4.1.5, End Treatment .
12.	Status Bar	Indicates the operational status of the Exablate Neuro and the water system, and the status of the MRI. See the Section 4.1.6, Status Bar .

4.1.1. Navigation Bar





Exablate Neuro treatments are divided into two stages: **Planning** and **Treatment**. The **Planning Stage** is dedicated to the acquisition of planning MR images, delineation of non-pass regions and target determination, while the **Treatment** stage is where the actual treatment sonications are performed and reviewed. Each stage has a dedicated Navigation Bar.

4.1.1.1. Plan Navigation Bar

The Navigation bar displays the different stages and sub-stages of the treatment and informs the user which stages/sub-stages have already been completed.

3. PLAN includes the following substages: Calibration, Scan, NPR Review, Registration, AC-PC Plane and Targeting.
4. THERAPY Button.

The different states (communicated visually) of the Stages & Substages:

- Unavailable – user cannot enter stage/substage 
- Available – user can enter stage/substage 
- Available (Call to action, substage only) – available and animated 
- Active – user is in stage/substage 
- Complete (substage only) – critical task of substage complete, user can still enter substage 

4.1.1.2. Therapy Navigation Bar

The Therapy navigation bar includes a visual representation of the active sonication substage (define, sonicate, review) in different states (empty ● (not performed yet), active ●, complete ●) with an added visual representation of the cyclical nature of the sonication.

See Section 9.1.1, **Therapy Stage Navigation Bar** for more details.

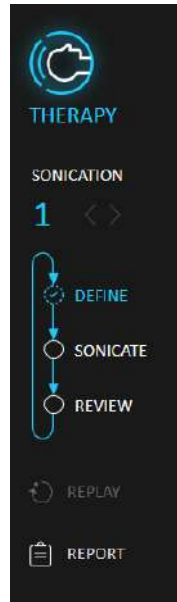

Figure 4-2: Therapy Navigation Bar

Displays the current sonication number and allows the user to enter "replay" mode and cycle between the sonications (See the **REPLAY MODE** Chapter).

The "Report" button that opens up the "report" panel (See the **Treatment Summary table**).

4.1.2. Image Thumbnail Bar

The Image Thumbnail bar represents a list of loaded (See section 4.3, **Image Retrieval Dialog**) and scanned images series in the WS. The displayed list may vary between sub-stages, displaying only the relevant series for the current sub-stage/stage.

The thumbnail bar is used for selecting series to the different windows, via drag-and-drop or by other mechanisms like double-clicking or right-clicking with the mouse.

The data of each series is represented as follows: MR (Series name, Orientation (slice #)) and CT (Series Name, Kernel (slice #)).

Images in the image thumbnail bar are divided into the following categories:

- Thermal (Therapy only)
- Intra-operative (live)
- Pre-operative
- CT
- Reference and Detection (Movement Detection screens only)
- Calibration

Hovering over a thumbnail trigger a dialog box with more image information (see image below).

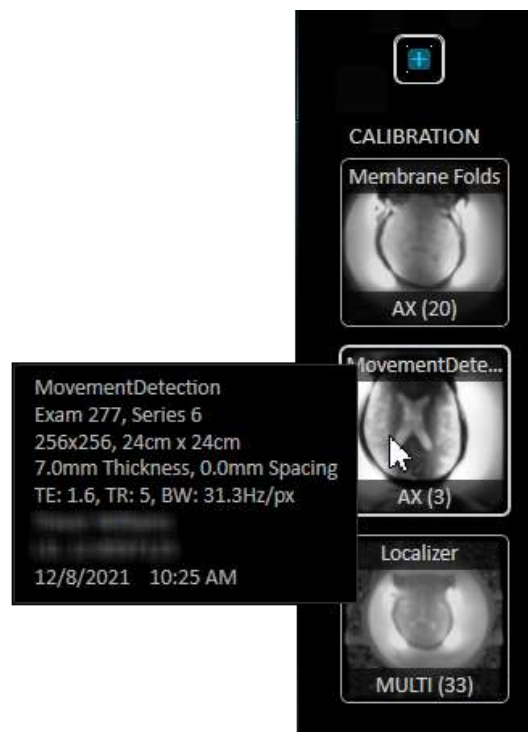



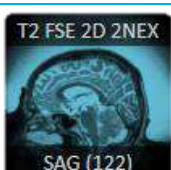

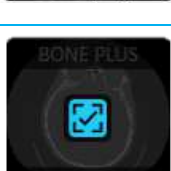

Figure 4-3: Tooltip Image Information Example

4.1.2.1. Image thumbnail visual indications

Image thumbnails support the following state indications (visually distinct):

	<p>Available for loading</p>
	<p>Unavailable to load</p>
	<p>Loaded into image viewing window</p>
	<p>Thumbnail appearance when in "Compare" mode</p>
	<p>Semi-registered (Registration substage only) – Denotes images for which an auto-registration result has been calculated</p>
	<p>Registration Approved (Registration substage only) – Images for which registration has been reviewed and approved by the treating physician</p>
	<p>Reference Set (Registration substage only) – Series set to which the system performs a registration with all the other Intra-operative series automatically.</p>

Specific substages shall support additional options in the right-click menu

4.1.2.2. Load images from Thumbnail bar

The operator can load images from the Image thumbnail bar into the Image viewing windows.

Right clicking on a thumbnail during the planning stage opens a right-click menu with the following options:

- Available series:
 - Load – Load the selected series to the selected image window.
 - Load to all – Load the selected series to all image windows.
 - Delete series (Note that Movement Detection Localizer image strips may not be manually deleted)
- Un-Available series:
 - Remove series

Specific substages may have additional options for this menu (e.g. the registration substage).

4.1.3. Image viewer window

The image viewing window is the area on the screen where the operator observes and interacts with the images. The operator can load images from the Thumbnail bar (See Section **4.1.2, Image Thumbnail Bar**).

There are three image viewer windows (one main and two secondary). Each window presents a single image of a selected series at a time. It is possible to switch between the images using the cycle tool.

Each substage has its own default contents and definitions of image viewing window states:

- Per window - Loaded image type and orientation
- Reformat orientation locked/unlocked

4.1.3.1. Image Annotations

The image annotations consist of the following texts, distributed in the following locations of the image windows:

- Top-right corner: Image type, slice number, slice location
- Bottom right corner: Date/time, scan frequency direction arrow (when applicable)
- Bottom: Series name
- Middle sides, up and down: Orientation letters
- Top (Thermal only): Displayed phase time.

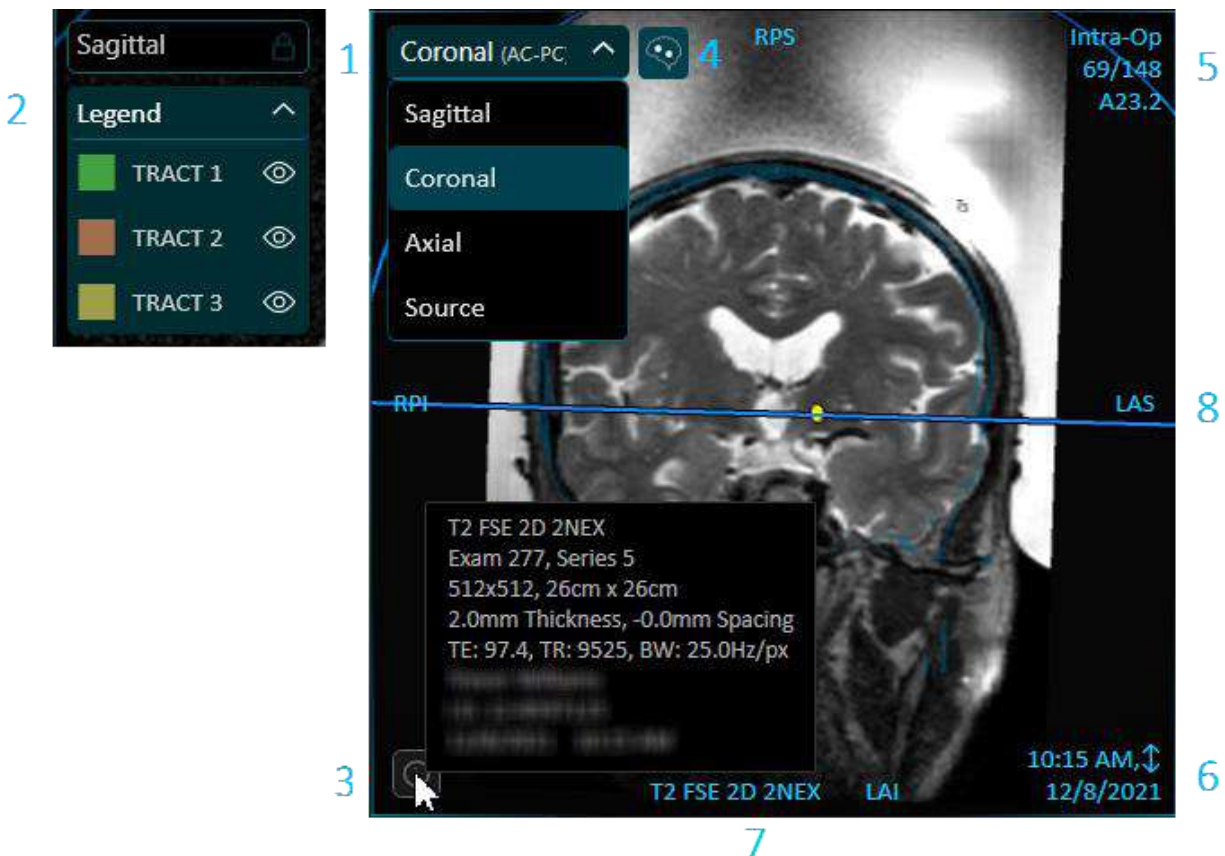

Figure 4-4: Annotations on Image Viewer Window

No.	Name	Description
1.	Orientation Controller	A drop-down menu controller enables the user to switch the "orientation" of the image type between Axial/Coronal/Sagittal/Source, see image above. It may be locked/unlocked based on substage definitions. In case of using tractography, a drop down menu controller will appear.
2.	Tracts Viewer Controller	The tract drop-down menu functions as a controller, allowing users to select and rename the desired tract from the available options. The controller appears only in case tracts were loaded. See section 4.4, Load and Visualize Tractography
3.	Info Icon	When hovered over, it displays image info tooltip.
4.	AC-PC Reformat Toggle	This button is available only once the AC-PC points have been approved. When ON, it enables the display of reformatted images based on the AC-PC landmarks. When OFF, it displays the reformatted images based on MRI coordinates.
5.	Slice Information Annotation	Annotations on the image will display slice information such as: <ul style="list-style-type: none"> • Image type • Slice #/total • Slice location

6.	Bottom Right Image Annotations	<p>These annotations will display:</p> <ul style="list-style-type: none"> • Time of the scan • Frequency direction used during the scan • Date of the scan
7.	Series Name	Annotation indicating the series name
8.	Coordinates system Indicators	Annotation indicating coordinate system indicators

For additional navigation controls regarding thermal images, see the **TREATMENT: THERAPY STAGE** Chapter.

4.1.3.2. Shadow Cursor

While hovering the cursor over an image, an additional small, green cursor will appear at the same location on all registered images as well as any images belonging to the same exam to point out a coordinate that is shared between these images.

4.1.3.3. Cursor Coordinates

The cursor coordinates indicate the location of whichever anatomical feature is being hovered over in all three planes.

There are multiple coordinate systems displayed in the cursor coordinate area throughout the treatment:

1. **Treatment MR Coordinates (Tx MR)** – These are the RAS Coordinates of the treated patient relative to the MRI Exam landmark. These are the 'real world' coordinates of a treatment and are used for consistency on targeted anatomy to keep all image sets aligned.
2. **AC-PC Coordinates** – This coordinate system is defined relative to the AC-PC Plane. The operator will define the axes orientations on the intra-operative images by placing the AC, PC and midline. For example, (0,0,0) is at the PC.
3. **Source Coordinates** - The native RAS coordinates of the images. If the source and the Tx MR coordinates are the same, only the Source Coordinates will be displayed.

For pre-operative CT or MR images, the Source and MR Tx coordinates will be different so therefore both will be displayed on the image.

4. **Unadjusted Coordinates** – See Section 4.1.3.4, **Additional Cursor Coordinates**



WARNING:

W061

A discrepancy in the RAS coordinates between different Pre-operative series may indicate patient movement during image acquisition. If such a discrepancy is detected during Pre-planning, perform registration for each strip independently.

4.1.3.4. Additional Cursor Coordinates

The MR Treatment table contains an additional set of trackers which enable localization of the transducer relative to the MR table. These enable the system to account for cases where the patient and transducer move together slightly, due to some freedom in the table's range of movement. Such a movement (as opposed to a patient movement) does not pose a risk and can be accounted for by:

(Adjusted) Treatment MR Coordinates – RAS Coordinates of the treated patient, relative to the Helmet System. These replace the original (unshifted) coordinates to serve as the 'real world' coordinates of a treatment, used to place a spot on targeted anatomy to keep all image sets aligned.

(Unadjusted) Treatment MR Coordinates – If a cradle movement (**not** patient movement) within acceptable limits has been detected, as mentioned above, the Source coordinates will be shifted to compensate for the shift. The unadjusted (original) coordinates will be displayed in parentheses, to act as a reference point if necessary. The unadjusted slice location will also appear next to the slice location annotation, in parentheses.



Figure 4-5: Cursor Coordinates

(in this example the entire cradle (Inc. Helmet System and 'patient') are shifted Superiorly by 0.6mm)





WARNING:

W039D

Due to shift compensation, a discrepancy between the RAS coordinates on the Exablate workstation and the MR Workstation may occur. During a treatment, always refer to the Exablate workstation coordinates (See Additional Cursor Coordinates Section).

4.1.4. Title Bar

The Title Bar supplies general information and general functionality such as:

- Date
- Time
-  **Sound** – Enables adjusting the system sound volume, and muting\unmuting. If muted – will be unmuted for patient stop sonication sound.
-  **Settings** – provides access to the **Settings** menu. See Section 10.5, **System Settings (Treatment Mode)**.

Availability of the settings button varies depending on system state and flow.

- **MRI Scan progress bar** – with a Stop button enabling the operator to stop the scan.



- **Software based Stop Sonication button** – enables the operator to stop the sonication from the software.

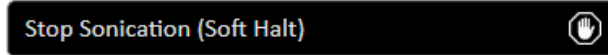

4.1.5. End Treatment

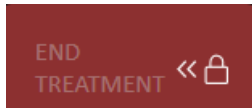

To End the treatment, slide the lock to the left and then press the button.

For other non-treatment sessions (DQA/ Screening/ Offline Replay/ Planning) only press the button.

4.1.6. Status Bar

The status bar displays the operational status of the Exablate Neuro and water systems as well as the status of the MRI.



Figure 4-6: Device and MR Status Bar

Right click on the water system icon enables to Pause, Resume or Reset the water circulation.

Verify that the buttons in the Status Bar are “ready” or “idle” before proceeding to patient positioning. When the buttons are in another status, follow the system's on-screen instructions.

4.2. Tool Bar

The toolbar is used for managing the treatment planning stage, DQA stage and therapy stage.

It includes various tools for manipulating the image display and adding measurements as well as displays various elements on the screen and special display modes.



NOTE:

N029

All user editing and interaction with graphic objects is performed in the selected image window **only**.

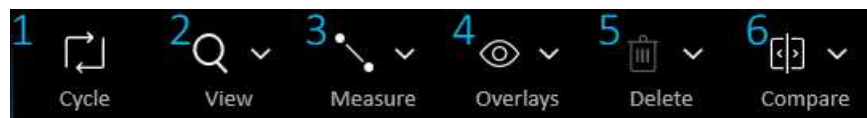

Figure 4-7: Tools Bar Structure

No.	Name	Description
1.	Cycle	This button cycles images between the different image viewer windows.
2.	View	This button opens the view drop-down menu. The master button turns on the last view tool used from the View menu. The specific icon is presented on the button. For further details, refer to the View section. Section 4.2.1, View .
3.	Measure	This button opens the measure drop-down menu. The master button turns on the last measurement tool used from the Measure menu. The specific icon is presented on the button. For further details, refer to the Measure section. Section 4.2.2, Measure .
4.	Overlays	This button opens the overlays drop-down menu. The master button provides a hide-all capability. Upon entrance to a substage or tool selection, relevant overlays are automatically turned ON. For further details, refer to the Overlays section. Section 4.2.3, Overlays .
5.	Delete	This button opens the delete drop-down menu. The master button allows the operator to delete the selected object. For further details, refer to the Delete section. Section 4.2.4, Delete .
6.	Compare	This button opens the compare drop-down menu. For further details, refer to Section 4.2.5, Compare .

4.2.1. View

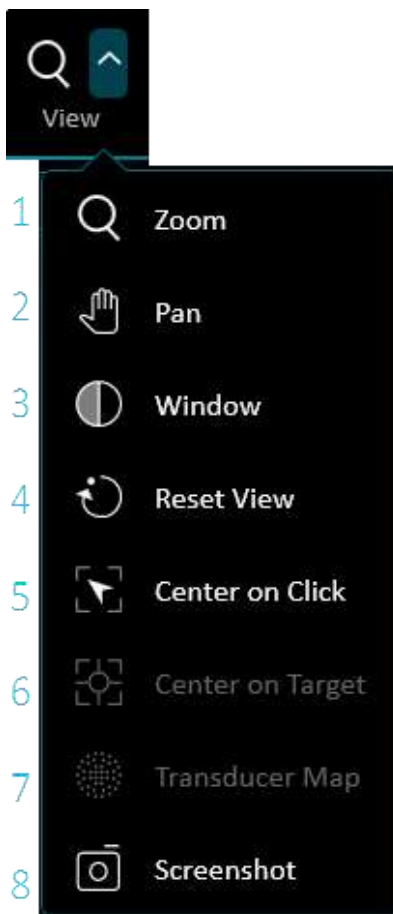

Figure 4-8: View Drop-Down Menu Structure

No.	Name	Description
1.	Zoom	<p>Zooms in and out on the displayed image.</p> <ul style="list-style-type: none"> To zoom in, drag the mouse up. To zoom out, drag the mouse down. <p>Zoom is mapped by default (or when no other tool is selected) to the left mouse button.</p>
2.	Pan	<p>Navigates around a zoomed image.</p> <ul style="list-style-type: none"> Drag to pan the image. <p>Pan is mapped by default to the right mouse button.</p>
3.	Window (Modify Contrast & Brightness)	<p>Press this button to change the image windowing (brightness or contrast). Drag the mouse up to brighten and down to darken the image. Drag the mouse left to increase the contrast and right to decrease the contrast. The change is automatically reflected in all the other images on the same type of strip.</p> <p>Windowing is mapped by default to the mouse wheel (when pressed).</p>
4.	Reset View	<p>Restores all images to default zoom, pan, contrast, and brightness settings. Reset applies to all windows that house the same image series.</p>
5.	Center on Click	<p>Press this button and then select a location on any image. By pressing on it, images will appear in the image viewer windows at that same location in the corresponding axes.</p>
6.	Center on Target	<p>This button shows the target in all image viewer windows.</p> <p>This option is available after defining a target (Targeting Stage).</p>
7.	Transducer Map	<p>Press this button to view the transducer map, see Section 4.2.1.1, Transducer Map This option is available after defining a target (Targeting Stage).</p>
8.	Screenshot	<p>Press this button to take a screenshot of the screen and save it in the treatment database. See the DATA MANAGEMENT Chapter.</p>

4.2.1.1. Transducer Map

The transducer elements floating window displays the **Transducer Elements Map** and the **Transducer Elements Parameters** for the sonication spot. The rays from the transducer elements to the sonication spot can be seen on the image (a ray defines the acoustic path from a single element to the sonication spot).

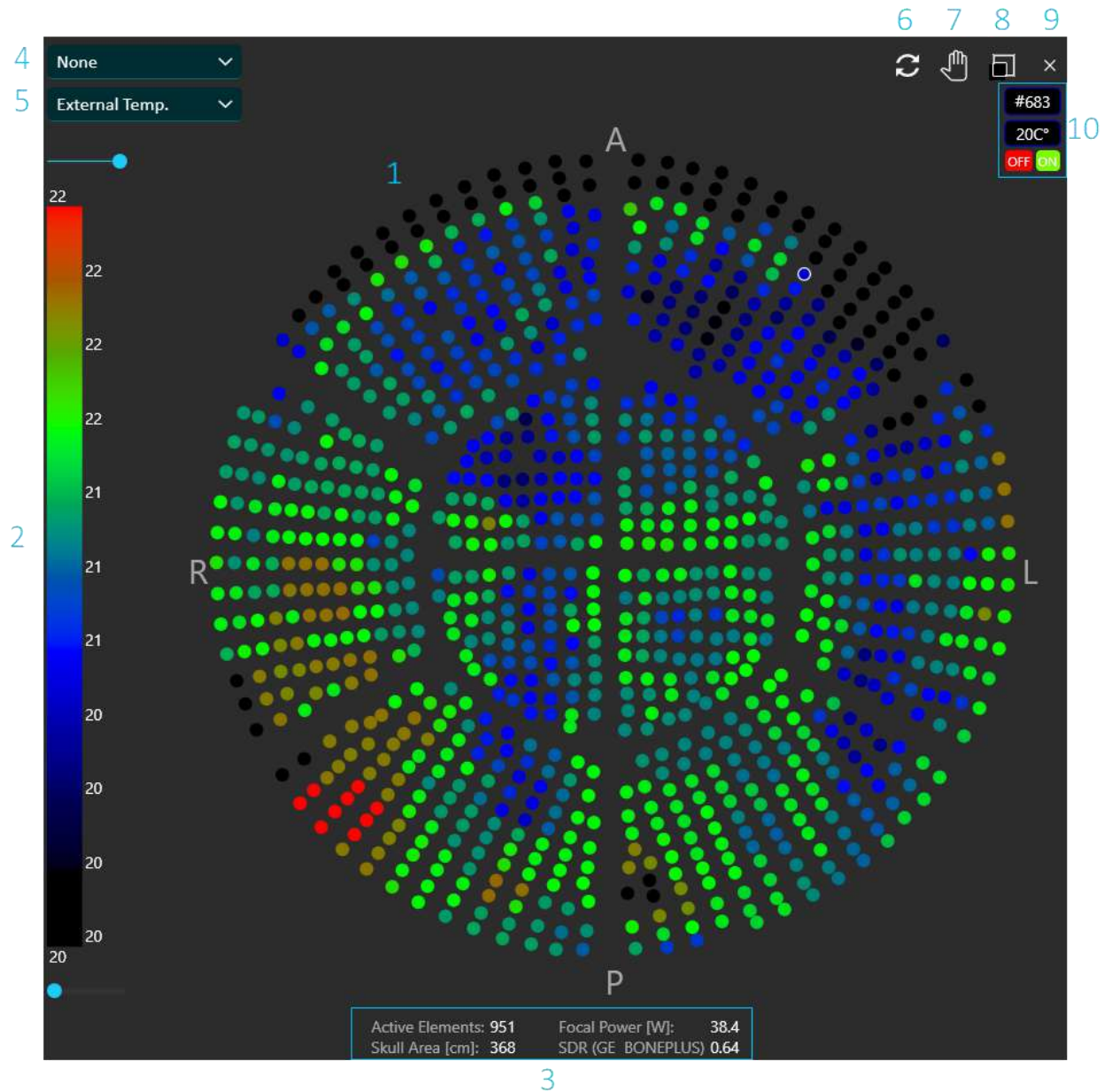

Figure 4-9: Transducer Elements Window

No.	Name	Description
1.	Transducer Map	Displays the Transducer Elements Map and the Transducer Element Parameters for each sonication spot.
2.	Set Map Range	Map range of the transducer map. Slide the upper scale to modify the upper extremity range of the scale. Slide the bottom scale to modify the lower extremity range of the scale.
3.	Transducer and Skull Parameters	Displays the transducer parameters, see Section 4.2.1.1.2, Transducer and Skull Parameters
4.	ACT Mask	The ACT file determines the amplitudes and phases of the transducer elements. ACT Masks are typically used to address spot distortion. Press the drop-down menu of all available masks to select the required ACT file. In a standard flow, “Default” ACT option will be used for no ACT mask.
5.	Transducer Elements Map	See Section 4.2.1.1.1, Transducer Elements Map .
6.	Refresh	This button enables the operator to refresh the transducer element map calculations if a change was made.
7.	Move window	This button moves the Transducer Map Window around the screen.
8.	Restore window size	This button enables the operator to restore widow size.
9.	Close window	Press this button to close the Transducer Map window.
10.	Single Element Parameters	Select element(s) from the 4.2.1.1.1, Transducer Elements Map by pressing on it. Press ctrl to select multiple elements at once. The following will be shown on the Transducer Map Window: <ul style="list-style-type: none"> • The selected Element’s Parameters • Option to turn the selected element(s) ON or OFF Press ON to turn ON or OFF to turn OFF. The reason for an element turned OFF will be shown in the waiting message area on the screen.

4.2.1.1.1. Transducer Elements Map

For each sonication spot, it is possible to view its derived **Transducer Elements Map**.

Each of the following profiles can be displayed on the map:

The **Average Power** (in Watts) transmitted from each element.

The **Phase Correction** (in degrees) applied for the skull aberration correction of each element.

The **Thickness** (in mm) of the skull that the ray passes through.

The **External Angle** (in degrees) between the ray and the skull surface at the intersection area

The **Air in Skull** (in mm) along the ray path

The **Internal Temperature** (in Celsius) estimation of the brain tissue temperature at the inner surface of the skull

The **External Temperature** (in Celsius) estimation of the temperature at the skin adjacent to the skull

The **Ray Shift** (in mm) as a measure of ray refraction

The **Skull Average Intensity** (in Watts/cm²) shows the average acoustic energy density on the surface of the skull.

The **Manual Disabled** displays the elements that were manually turned OFF by the operator.

The **Skull Score** calculation for each element

4.2.1.1.2. Transducer and Skull Parameters

General parameters of the transducer are displayed:

The **Active Elements** displays the total number of transmitting elements.

The **Skull Area** (in cm²) displays the total area of the skull that the rays pass through.

The **Focal Power** (in Watts) displays the estimated peak power that reaches the target location after traversing through the skull and brain tissue.

The **SDR (Skull Density Ratio)** reflects the variability in the bone density of the entire skull.

The **CT Filter** type displays the filter that CT images were reconstructed with.



NOTE:

N069D

- A minimum of 700 elements ON is advised for an effective treatment.
- Available skull area should exceed 200 cm².



NOTE:

N081D

Values with squiggles (e.g. SDR: ~0.65) indicate that the results may have changed since last calculated. Refresh the information to update values.

4.2.2. Measure

The Measure drop-down menu shows the different measure tools available for use. Pressing the measure button enables or disables the measuring tool. The icon above the measure tool in the Tool Bar shows which specific tool is currently active from the list.

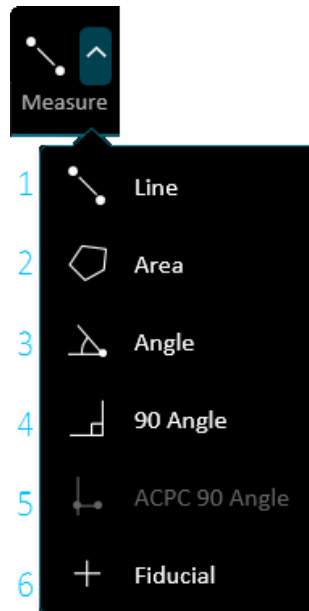

Figure 4-10: Measure Drop-Down Menu Structure

No.	Name	Description
1.	Line	<p>Enables the user to measure the actual distance between two points:</p> <ul style="list-style-type: none"> • Select an image. • Click on the first measurement point and then on the second one. • Double-click to complete the measurement command. <p>The system automatically calculates and displays the distance between the two points. Distance measurements and their labels can be moved and adjusted by clicking and dragging the points at the ends of the line.</p>
2.	Area	<p>Enables the user to measure the attributes of a drawn polygon:</p> <ul style="list-style-type: none"> • Select an image. • Click on the first measurement point of the polygon. • Continue to draw the outline of the polygon with single clicking. • Click on the last measurement point of the polygon to close it. <p>The system automatically calculates and displays:</p>

		<ul style="list-style-type: none"> The polygon's average pixel value polygon (only on Thermometry and Source intra-operative and pre-operative images). The standard deviation of pixel values within the polygon (only on Thermometry and Source of intra-operative and pre-operative images). <p>NOTE: on a temperature map, the pixel value is the temperature value.</p> <ul style="list-style-type: none"> Area measurement and their labels can be moved by clicking and dragging the polygon outline.
3.	Angle	<p>Enables the user to measure an angle:</p> <ul style="list-style-type: none"> Select an image. Click on the first point of the angle to be measured. Move the cursor to the second and third points and click again. <p>The system automatically calculates and displays the selected angle.</p>
4.	90 Angle	<p>Enables the user to place a 90 degrees angle on the image:</p> <ul style="list-style-type: none"> Select an image. Click on the placing point of the 90 degrees to be measured. <p>The system automatically calculates and displays the selected angle.</p>
5.	ACPC 90 Angle	<p>This option is available only after approving the AC and PC markings. This enables the user to place a 90 degree angle on AC and PC markings.</p> <ul style="list-style-type: none"> Select an axial image Click on the ACPC 90 Angle Option. <p>The system automatically calculates and displays the selected angle based on selected intended target as defined in the entrance screen (and editable in the entrance screen lists screen).</p> <p>In a standard flow with a VIM target, the angle will be placed with one ray on the midline starting from the PC with a length of 25% of the AC-PC distance, and the second ray extending laterally to a length of 14 mm.</p> <p>See Section 10.4.2, Target Location List Management.</p>
6.	Fiducial	<p>Select this button, then point and click on the Selected Image window to place a Fiducial Marker on the screen.</p> <p>Fiducials are displayed in the same RAS location for all images which have 'Tx MR' or 'Source' coordinates and are particularly useful for comparing anatomical feature locations on Pre-operative and Intra-operative imaging, as well as for monitoring patient movement during a treatment session (in conjunction with the Compare Tool).</p>

4.2.3. Overlays

This section describes the overlay tools which toggle the graphic overlays onto the MR images. Pressing the Overlays button displays/hides the overlays on the image.



NOTE:
Overlay availability depends on treatment flow.

N031

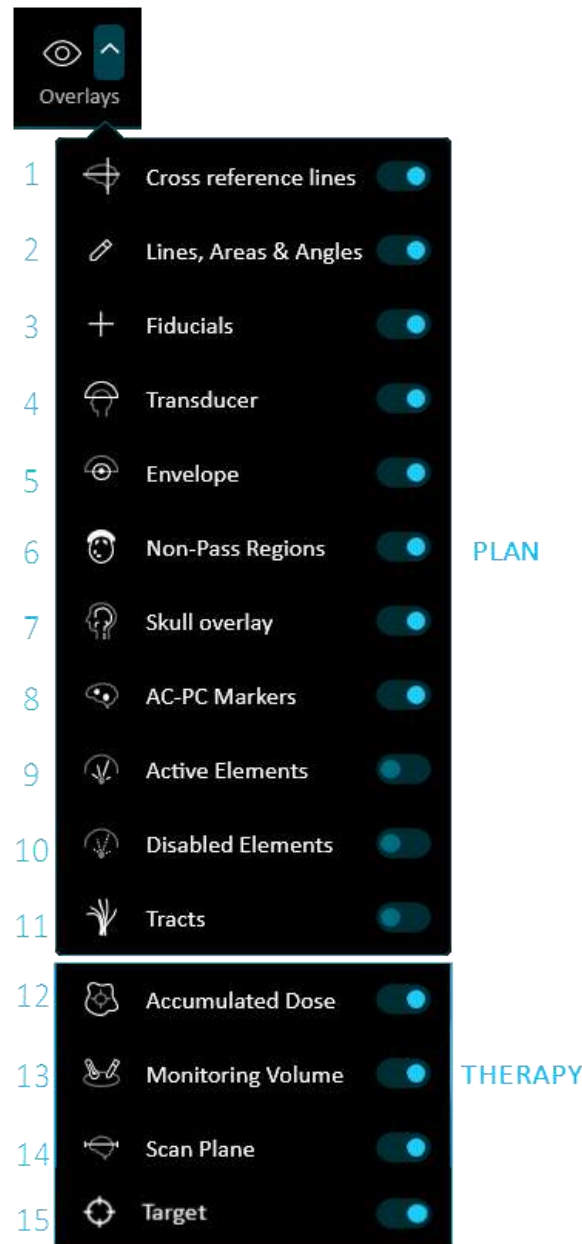



Figure 4-11: Overlays Drop-Down Menu Structure

No.	Name	Description
1.	Cross Reference Lines Toggle Button	Displays or hides the cross-reference line layer from the displayed image. The line shows the location of the slice currently being shown in a specific image viewer window.
2.	Lines, Areas and angles Toggle Button	Displays or hides the measurement graphic layers from the displayed images.
3.	Fiducials Toggle Button	Displays or hides the fiducial markers layer from the displayed image.
4.	Transducer Toggle Button	Displays or hides the transducer's template layer from the displayed image.
5.	Envelope Toggle Button	Displays or hides the circle that defines the treatable area (as governed by the extents of the transducer) from the displayed image.
6.	Non-Pass Regions Toggle Button	Displays or hides the contours of the NPR from the displayed image.
7.	Skull Overlay Toggle Button	Displays or hides the skull overlay layer from the displayed image.
8.	AC-PC Markers Toggle Button	Displays or hides the AC, PC, and midline markers from the displayed image.
9.	Active Elements Toggle Button	<p>After defining the target, you can view the rays from the transducer elements to the spot. A ray defines the acoustic path from a single element to the sonication spot.</p> <p>Press this button to display or hide the rays of transmitting elements from the displayed image.</p>
10.	Disabled Elements Toggle Button	<p>After defining the target, you can view the rays from the transducer elements to the spot. A ray defines the acoustic path from a single element to the sonication spot.</p> <p>Press this button to display or hide the rays of the non-transmitting elements from the displayed image.</p> <div style="display: flex; align-items: flex-start;"> <div style="margin-right: 20px;">  </div> <div> <p>NOTE: N071</p> <ul style="list-style-type: none"> ● For a non-transmitting element, the reason for non-transmission can be displayed in the wait message area by selecting the ray. ● Selected sonication spots or rays are highlighted. </div> </div>
11.	Tracts Toggle Button	<p>Displays or hides the tracts overlays from the displayed images.</p> <p>A Tractography image set is required, see section 4.4, Load and Visualize Tractography</p>

The below features are unavailable during the planning stage.

12.	Accumulated Dose	Press this button to show or hide the accumulated dose . See 9.1.4, Therapy Stage Overlays .
13.	Monitoring Volume	Press this button to show or hide the Temperature Monitoring Volume . See Section 9.1.4, Therapy Stage Overlays .
14.	Scan Plan	Press this button to display the locations of the MR thermal slices on the selected image window and on the image strips. See 9.1.4, Therapy Stage Overlays .
15.	Target overlay	Press this button to hide/display the target overlay, exclusively in therapy and replay modes. It automatically activates when transitioning between sonication stages. See 9.1.4, Therapy Stage Overlays .

4.2.4. Delete

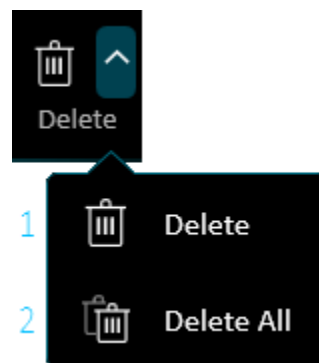

Figure 4-12: Delete Drop-Down Menu Structure

No.	Name	Description
1.	Delete	Delete the selected object. Applies to all types of measurements and NPR markings.
2.	Delete All	Delete all objects of the same type as the selected object. Applies to all types of measurements and NPR markings.

4.2.5. Compare

The compare menu contains three different tools to compare the series of images within:

Main series images

Secondary series images – The Secondary series image annotations will be shown in parentheses next to the main series images annotations.



NOTE:

N032

When the compare tool is ON, only the secondary image series can be modified for comparison. Choose the main series images on the main viewer window before entering the tool.

Three options are available from the drop-down menu of the tool bar:

- Swipe
- Flicker
- Fusion



NOTE: N039

Comparison should only be performed for image sets that are registered to each other.

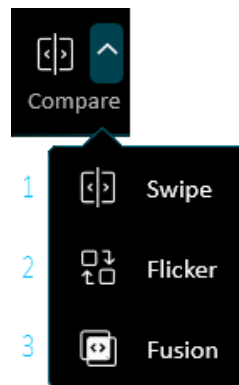

Figure 4-13: Compare Drop-Down Menu Structure

No.	Name	Description
1.	Swipe	The swipe tool enables the user to swipe one image across another chosen image (e.g., current movement detection images) in the selected image window/s. See Section 4.2.5.1, Swipe .
2.	Flicker	Iteratively passes between the reference image and another chosen image (e.g., current movement detection images) in the selected image window/s. See Section 4.2.5.2, Flicker
3.	Fusion	Combines the reference image and a chosen image (e.g., current movement detection images) in the selected image window/s. See Section 4.2.5.3, Fusion

4.2.5.1. Swipe

The swipe tool enables the user to swipe one image across another.

When the tool is ON, the main image viewer window is divided into two sections by a slider (Slider 1): Main images and secondary images. The main image is the image displayed in the main window before entering the tool. To compare the main image with another image, drag the secondary series of interest into the secondary image section to compare them (from the thumbnail bar). The two images will be superposed.

Use slider 1 to swipe one image series across the other.

Use Slider 2 to change the opacity of the secondary image above the main image.

See more Swipe options below:

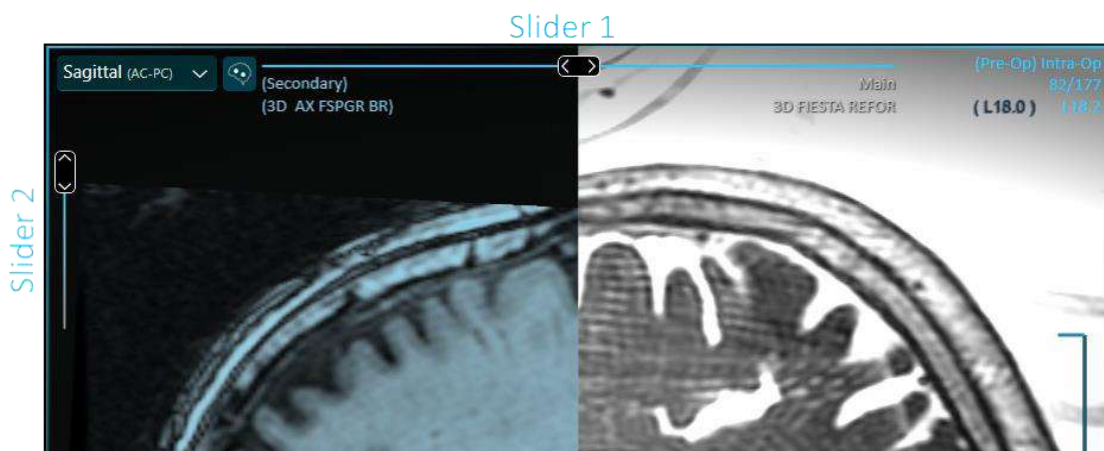

Figure 4-14: Swipe tool's Sliders



No.	Name	Description
1.	Swipe	Press this button to enter to the Swipe tool.
2.	Linked	Press the Linked button to Link/ Unlink the two secondary image viewers to the tool. Linked - The tool will be applied on the three image viewer windows. Unlinked – The tool will be applied only on the main viewer window.
3.	Show/Hide	Press this button to show or hide the tool.
4.	Color	Press this button to color the Secondary images to emphasize the difference between the two series for comparison. Click again to disable this option.
5.	Clear Images	Press this button to clear the Secondary images.

4.2.5.2. Flicker

The Flicker tool enables the user to iteratively switch between the reference image and a chosen image (e.g., current movement detection images) in the selected image window/s. The speed of the iteration can be controlled.

When the tool is ON, slide the image to compare it to the main image viewer window.

See more Flicker options below:

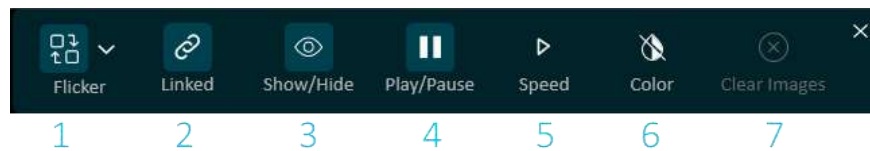

Figure 4-15: Flicker

No.	Name	Description
1.	Flicker	Press this button to enable the Flicker tool.
2.	Linked	Press the Linked button to Link/ Unlink the two secondary image viewers to the tool. Linked - The tool will be applied on the tree image viewer windows. Unlinked – The tool will be applied only on the main viewer window.
3.	Show/Hide	Press this button to show or hide the tool.
4.	Play/Pause	Press this button to Play/Pause the Flicker tool.
5.	Speed	Press this button to raise the iteration speed between the images. 3 different level of speeds are available.
6.	Color	Press this button to color the Secondary images to emphasize the difference between the two series for comparison. Click again to disable this option.
7.	Clear Images	Press this button to clear the Secondary images.

4.2.5.3. Fusion

In Fusion mode, the system displays a colored image that is the fused product of the primary and secondary images. The fusion image process enables the coalescence of the important information from the two images into a single “fusional” image.

The information from each one of the source images is represented by a corresponding color.

Fusion mode is controlled by a slider that controls the color proportions between the two images.

See more Fusion options below:



No.	Name	Description
1.	Fusion	Press this button to enable the Fusion tool.
2.	Linked	Press the Linked button to Link/ Unlink the two secondary image viewers to the tool. Linked - The tool will be applied on the tree image viewer windows. Unlinked – The tool will be applied only on the main viewer window.
3.	Show/Hide	Press this button to show or hide the tool.
4.	Color	Press this button to enable/disable the tint of the secondary image to be easily distinguished from the primary one.
5.	Clear Images	Press this button to clear the Secondary images.

4.3. Image Retrieval Dialog

The Image retrieval dialog is used during a treatment’s planning stage (and the preparation of a Pre-Planning Session). It allows the user to import CT and MR images into the treatment from the hospital system or directly from a CD or external storage device like a USB thumb drive.

To access this menu, press the 'Retrieval dialog' button on the 'planning' stage screen: 

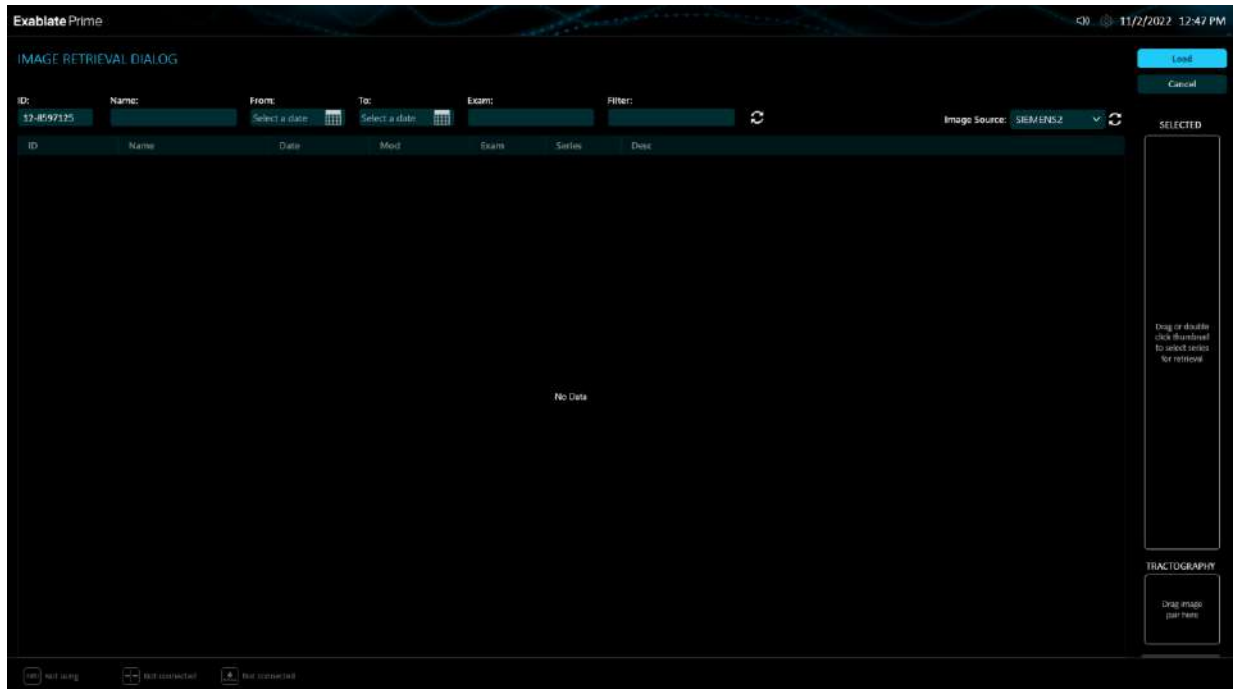

Figure 4-16: Image Retrieval Dialog Menu

- Chose the image source of the series to retrieve (e.g. MR, DVD, USB or PACS). The image source can be refreshed by pressing the “refresh button”. This happens automatically upon entry to the dialog and can be prompted on demand if:
 - Inserting a USB drive or DVD media
 - In case of missing items in the list

While refreshing, the icon assumes a “X” shape and the process can be stopped by pressing it.



NOTE:

N059D

File retrieval form external sources such as DVD or USB may be slower than expected.



NOTE:

N082

If sources are not appearing in the list press the refresh sources button or attempt to close and reopen the Image Retrieval Dialog. Wildcard (“*”) search is supported, but behavior may vary based on system configuration. Search by exam number may not be available for all configurations.

2. Use the search tools to find the required series by filling in various data fields (Patient ID, Name, Date, Exam, Filter). The filtering can also be refreshed on demand.
3. Select the required thumbnail file from the list. Double click on the image series or drag it to the thumbnail bar to select a series for retrieval.
To remove a series from the thumbnail bar, right click on the series and delete.
4. Click on the **Load** button to load the selected series to the planning stage or select **Cancel** to terminate a selection and exit the retrieval dialog. The selected series are then automatically sorted by type (CT/MR/Tractography) and orientation.

NOTE:

N030

Only series belonging to the active exam on the MR will be recognized as 'Intra-operative' images. Other MR image exams will be classified as 'Pre-operative' (during a pre-planning session all images are considered Pre-operative).

WARNING:

W062D

Ensure that the images of the CT series completely cover the skull: from one slice above the apex of the head to down below the brain, so that the system has adequate parameters of aberration correction of the acoustic beam (automatically) throughout the treatment, based on the specific skull characteristics.

4.4. Load and Visualize Tractography

Tractography is a 3D/2D modeling technique used to visually represent nerve tracts using data collected by MRI. The nerve tracts are presented in two and three-dimensional images called tractograms.

The system allows the user to load tractogram images, extract the marked nerve tracts from them and display the result on WS images.

When placing a target, it may be prudent to avoid damage to certain nerve tracts.

4.4.1. Load Tractography

Within the Image Retrieval dialog there is a specific window for the tractography image loading process.

1. The user should drag multiple series into this 'Tractography' window:
 - The original pre-operative MRI images without marked tracts
 - One or more of the same pre-operative series but with marked tracts on it (as prepared using a third-party software)

Make sure selected series of images have the same number of slices, image size, voxel size and frequency direction.

2. Press **Load** to load the images to Treatment/Pre-planning and exit the Image Retrieval Dialog to proceed to the automatic calculation of the tract overlays (See section **4.2, Tool Bar**).
 - The tractography image set will be represented by a single thumbnail of images and is considered a pre-operative image.
 - The tractography overlay will become visible after the registration sub-stage.

Multiple series with different tracts can be loaded, providing flexibility in visualization:

- Load one series for each tract to separate and be able to label and visualize each tract individually.
- Consolidate all tracts into a single series for a unified overlay.

4.4.2. Visualize Tractography

After tracts are loaded successfully, a visualization controller will appear in the top-left corner of the main window.

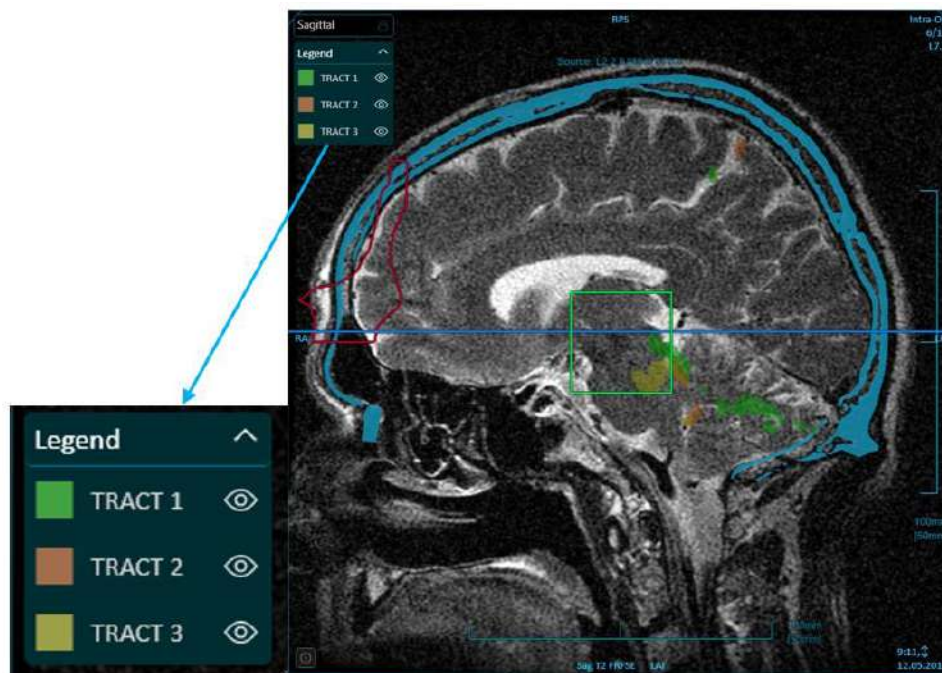

Figure 4-17: Tractography visualization and Legend

The tract drop-down menu acts as a controller, allowing users to select and rename their desired tract from the available options. This controller appears only when tracts have been loaded.

Each tract is assigned its unique color for distinction.

- To rename a tract, simply double-click on its name.
- To show or hide a specific tract overlay in the image window, click on the eye icon next to the name.

During the preplanning session, tract names will be saved.

5. DAILY QUALITY ASSURANCE (DQA)

This chapter details the Daily Quality Assurance (DQA) procedure.

The DQA procedure is to be conducted at the start of each day (prior to the treatment\’s), to verify proper operation of the Exablate Neuro system.

The instructions below provide a general outline of the DQA procedure.

Accessories required for the DQA procedure:

DQA Phantom Gel– Semi-solid, water-based, crossed-linked gel mimicking brain tissue.

DQA Phantom Gel Set Up holder – holds the gel and seals the transducer during the DQA procedure.



WARNING:

W063

Violation of the DQA Phantom Gel handling policy as defined in ‘Handling Instructions of DQA Phantom Gel’ may lead to false or unreliable DQA results.



WARNING:

W064

Visually inspect the kit before use.

If there are signs of visual damage or if the freeze indicator is activated (see picture below), contact your InSightec representative.



5.1. DQA Set Up Procedure



NOTE:

N033

- It is suggested to keep the *Handbook* accessible near the system for a step-by-step checklist of the DQA procedure flow.
- Follow the instructions to ensure that the system is functioning properly and verify DQA results.

Prior to starting the DQA, confirm the following:

1. Reboot the MR system if it has not been rebooted that day.
2. Power on the system.
3. Visually check the integrity of the transducer:
 - For loose fittings or damage
 - For any loose or damaged connectors or water lines on the patient table
4. Ensure that the patient table and HS are completely set up and ready (as detailed in the **GETTING STARTED** Chapter).
5. Place the DQA phantom gel and holder onto the transducer and seal it. To optimize performance it is recommended to avoid applying any tilt to the transducer.



CAUTION:

C044

Be careful not to drop the DQA phantom gel or set up on the transducer.

6. Fill the transducer with water.
7. Apply Landmark according to the Landmark Labels that were placed on the cradle and table (or connect the PHILIPS landmark accessory). Ensure that both labels are accurately aligned before performing the landmark (see **Figure 5-1**).



Figure 5-1: Aligned Landmark Labels

8. Ensure that the cables are free to travel with the patient table.
9. Send the Exablate cradle to the center of the MR bore and define the landmark/iso-center at the center of the transducer's rim.
10. Open a new exam on the MR console.

11. Proceed to the Section 5.4, DQA Flow.

5.2. DQA Set Up Holder

Note: The DQA Set Up Holder description below is relevant for all types of membranes.

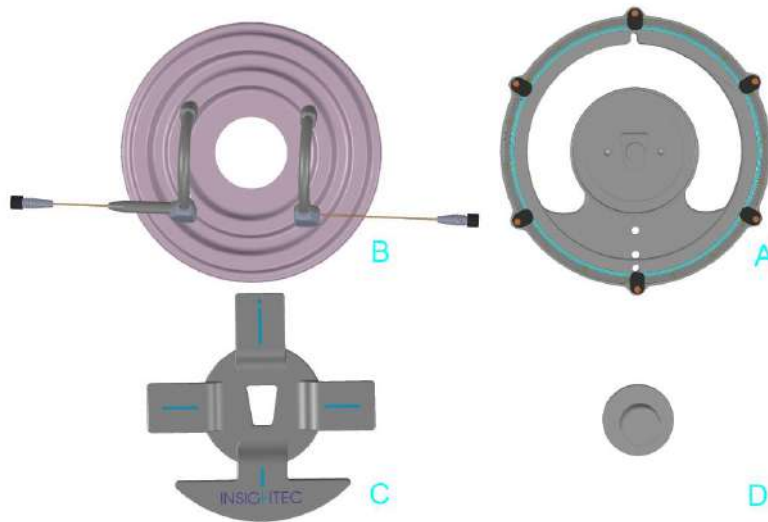

Figure 5-2: DQA Set Up Holder Components. Phantom Gel Holder (A), Patient Membrane (B), Membrane Holder (C), Lock (D), – for illustration only .

Components required for the DQA Set Up Holder (as shown in the figure above):

- A- Phantom Gel Holder: Holds the DQA phantom Gel, seals the membrane Holder and connects the Set Up to the transducer.
- B- Patient Membrane (with or without a coil)
- C- Membrane Holder: Holds the Membrane
- D- Set Up Lock: Locks parts A, B and C together

A Mounting Jig is available to support the Set-Up process.

Place the Holder on top of the Mounting Jig and interlock the two pieces together.

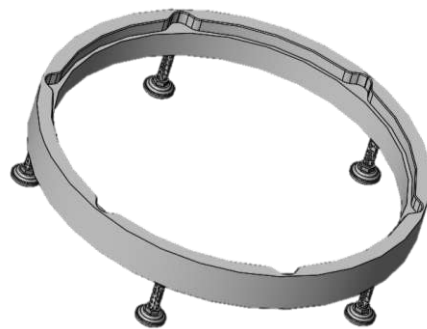

Figure 5-3: Mounting Jig

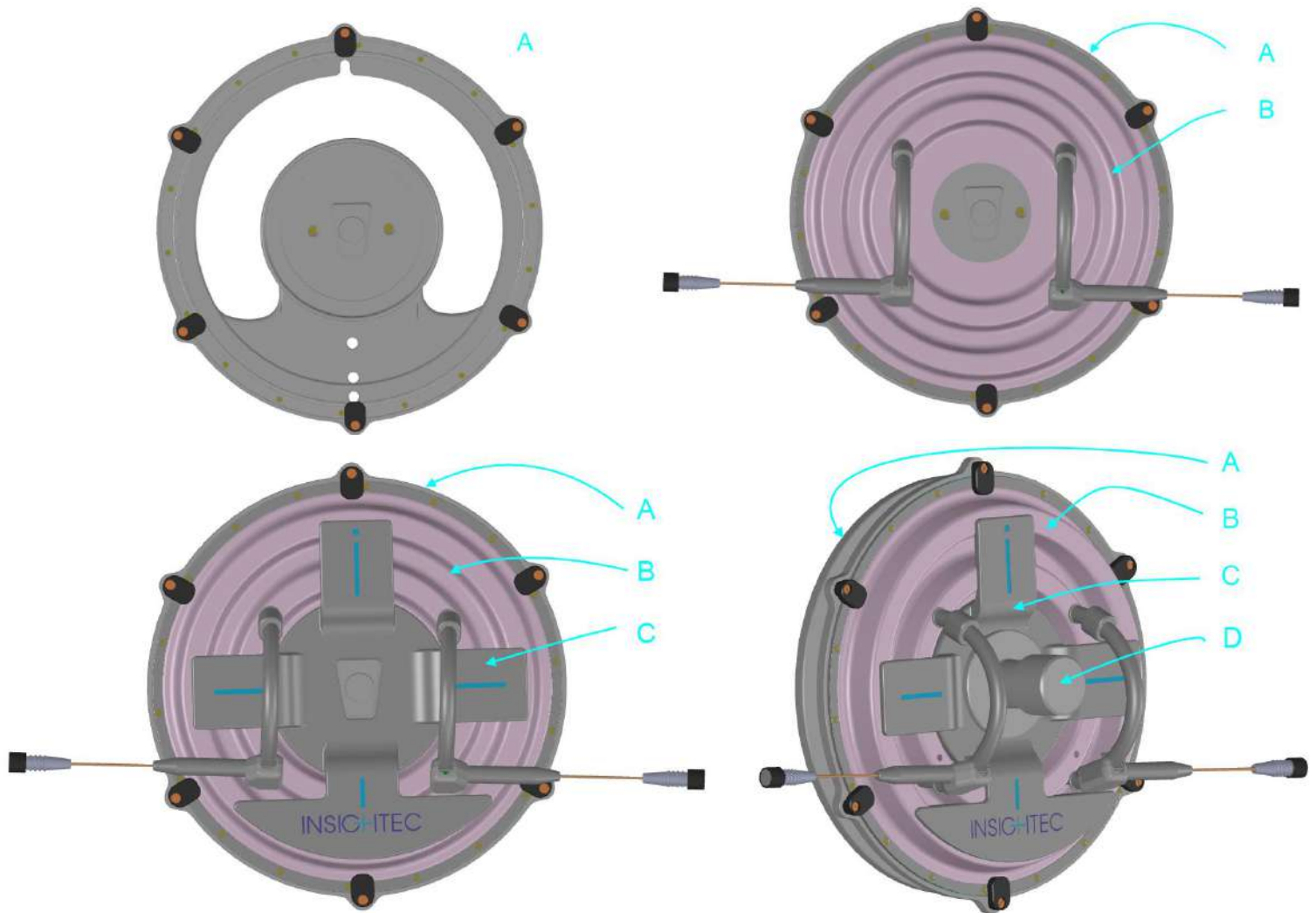

Figure 5-4: DQA Set Up Holder Assembly Steps

Step 1 (A, B): Position the membrane onto the Phantom Holder, lock the membrane to the holder via the latches.

If applicable, position the Head Coil Plug Connectors on either side of the Holder in a parallel manner.

Step 2 (A, B, C): Position the membrane Holder (C) centrally onto the assembly from Step 1.

Step 3 (A,B,C,D): Screw the Lock (D) to the Holder screw on (C) to secure the pieces together.

To Prepare DQA phantom Gel for use:

1. Open the bag and retrieve the DQA phantom Gel.
2. Place the DQA phantom Gel into its dedicated slot in the 'DQA phantom Gel holder'.

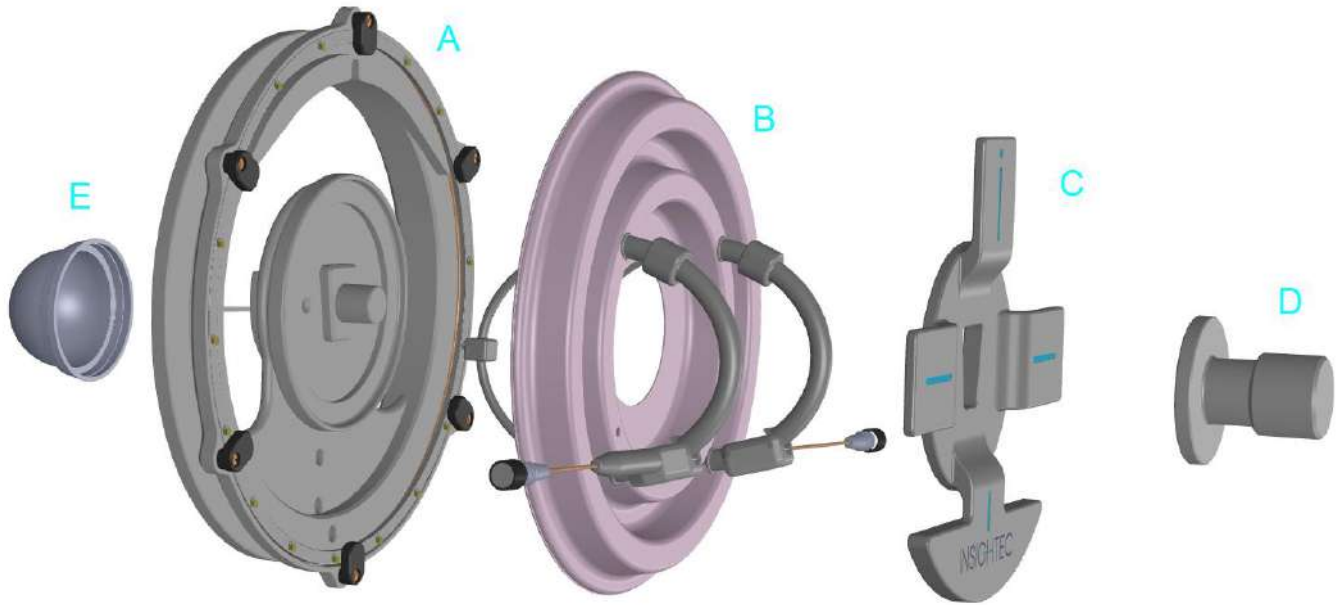

Figure 5-5: 3D break down of DQA Set Up Holder Assembly. DQA Phantom Gel (E), Phantom Gel Holder (A), Patient Membrane (B), Membrane Holder (C), Lock (D), – for illustration only.

5.3. Handling Instructions of the DQA Phantom Gel

The DQA phantom gel is a Semi-solid, water-based, cross-linked gel, delivered in a sealed aluminum bag. To prepare a DQA phantom for use and to set up the DQA Holder, see Section 5.1, **DQA Set Up Procedure**. If needed, a single DQA phantom gel is verified for re-use up to five times. Once used up\expired\ no longer required - dispose of the DQA Phantom Gel according to local regulations.

5.4. DQA Flow

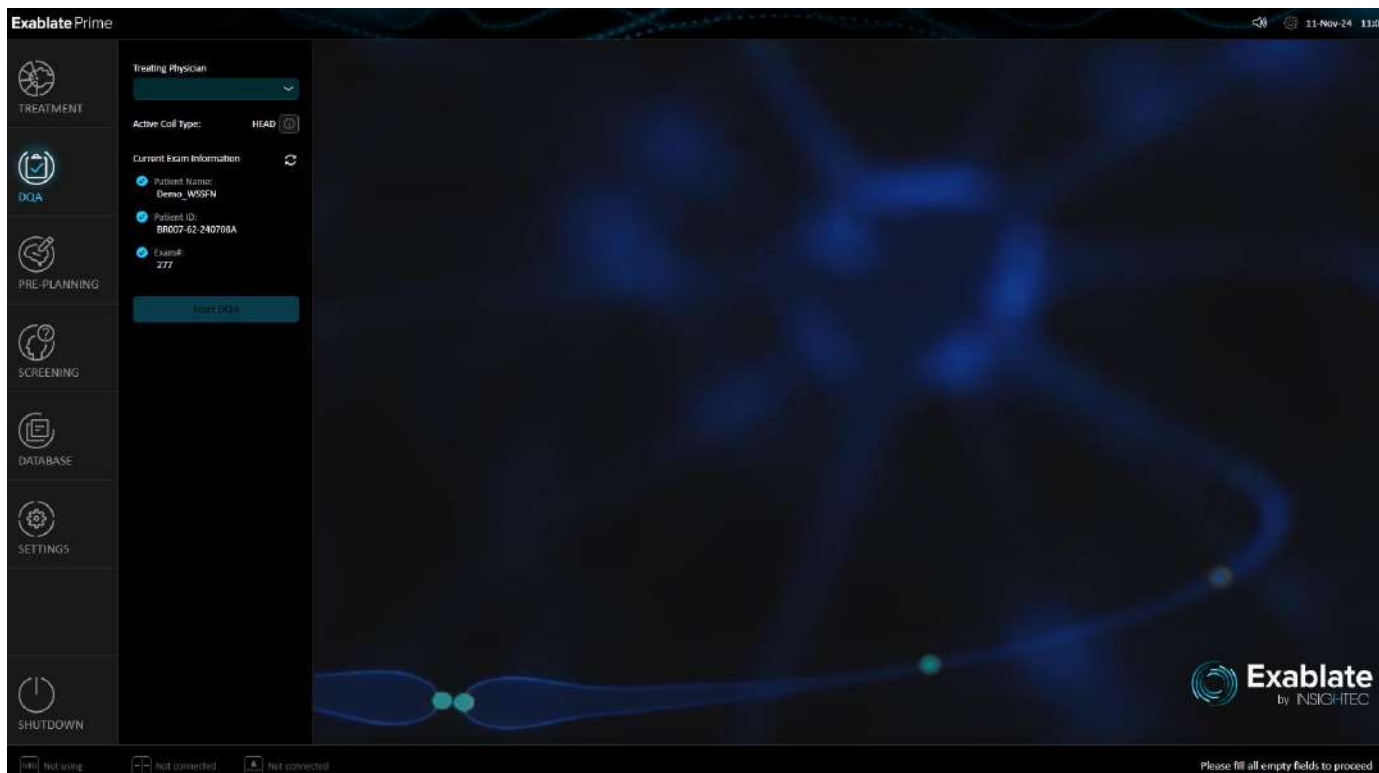





Figure 5-6: DQA Start-Up Screen

5.4.1. DQA Start Up

1. Enter the DQA Start-up screen.
2. Verify current exam information presented on the screen corresponds to the exam opened on the MR console and the active coil type is consistent with the DQA membrane used (if applicable).
3. Press Start DQA; The **DQA Set-Up Screen** will appear.

5.4.2. DQA Set Up Stage

4. Press Locate Transducer.  Locate Transducer
5. Press Find Central Frequency.  Find Central Frequency
6. Press Planning Scan.  Planning Scan
7. Press the stop sonication button inside the MR room.

- Verify all steps above have been completed on the screen and subsequently press the Sonicate button to be redirected to the Sonicate Screen.

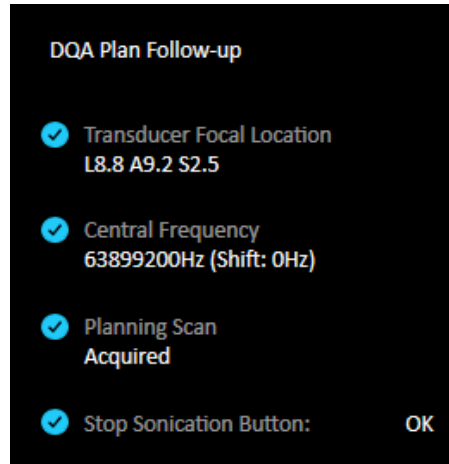

Figure 5-7: DQA Plan Follow-up

5.4.3. DQA Sonicate Stage

- Perform the predefined short treatment flow as follows:

- Perform at least two DQA-mode sonications by pressing the Sonicate button.
- Alternate between different scan orientations.



- When reviewing sonication results, ensure the following:

- Each thermal spot is centered around target or a Fiducial.



NOTE:

The accumulated dose overlay will only appear for the spot around the Transducer's focal point. N046

- Peak temperatures at each spot are 45°C to 50°C
- Sonication ends with a Cavitation Halt



CAUTION:

If any of the aforementioned inspections or tests fails to meet the expected values, or if you notice any other abnormalities (e.g. diffused spot, error messages, etc.), discontinue use of the system until it has been thoroughly inspected by an authorized InSightec service personnel. C022

This page is intentionally left blank for double-sided printing.

6. SCREENING (SDR CALCULATION)

6.1. Screening Screen

The screening tool allows the user to calculate a patient’s skull score (SDR), which may serve as a treatment inclusion/exclusion criterion.

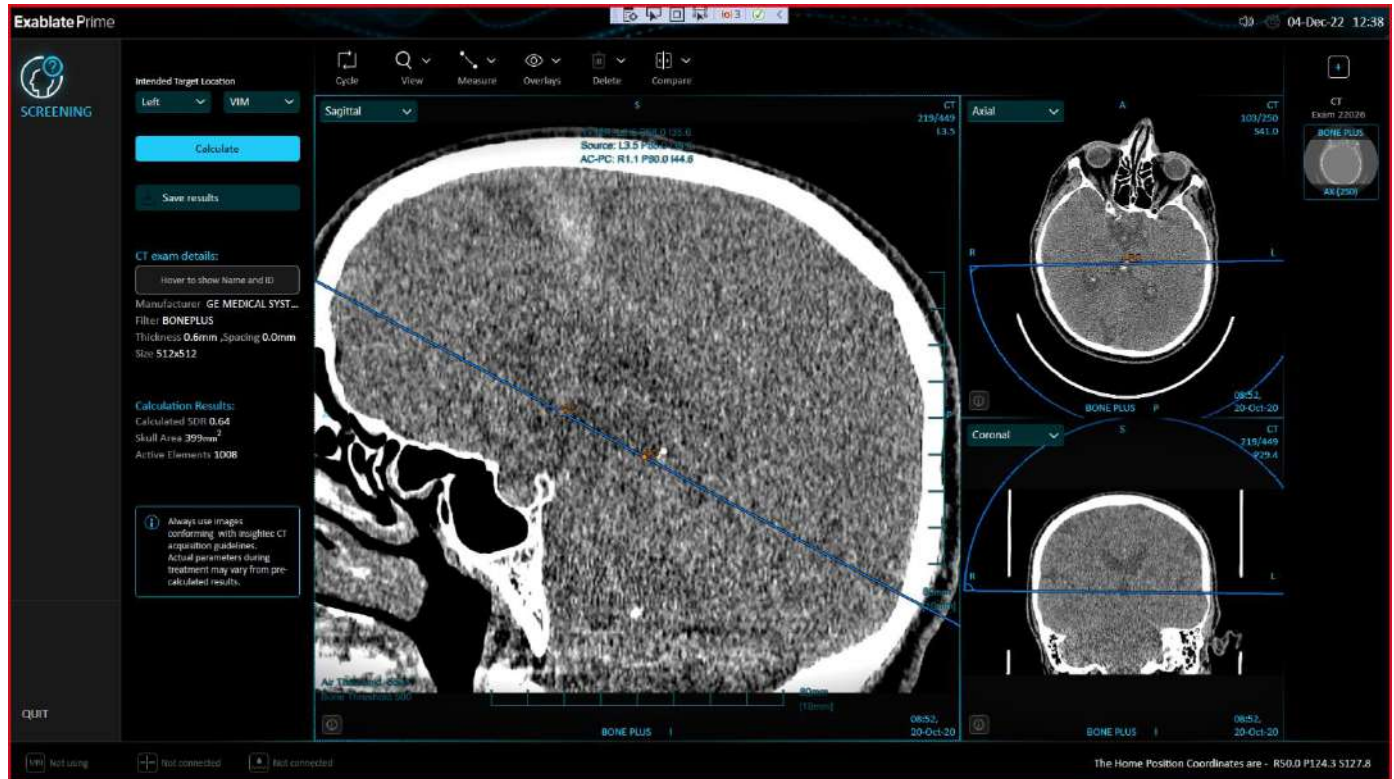

Figure 6-1: Screening Mode Screen

No.	Name	Description
1.	Intended Target Location	<p>Drop down with possible target locations as previously defined within the Settings Stage “define the target location” option in Target Location List management. The Transducer overlay will be placed automatically according to the defined target.</p> <p>In case of miscalculation, chose “manual” from the drop-down menu to manually place the transducer overlay.</p>
2.	Calculate button	<p>This button calculates the SDR, Skull Area and active elements according to the uploaded CT and Intended Target Location.</p> <p>This button is active only after the CT is uploaded.</p> <p>Calculation results will appear on the screen at the end of the calculation.</p>
3.	CT Exam Details	<p>Section describes the details of the CT exam.</p> <p>To show the Name and ID, Hover the hidid square.</p> <p>CT parameters that do not adhere to the CT screening guidelines will be noted on the screen.</p>
4.	Calculation results	<p>After the calculation is performed, the following calculation results will be shown on the screen:</p> <ul style="list-style-type: none"> • Calculated SDR • Skull Area • Active Elements
5.	Retrieval Dialog screen button	<p>This button opens the Image Retrieval Dialog screen.</p> <p>Note: Only one series of CT images can be loaded.</p> <p>For further details refer to the relevant section in TOOLS & OVERLAYS Chapter.</p>
6.	Save Results button	<p>This button saves the results to the DATABASE under the Screening Calculations Tab. (See DATA MANAGEMENT Chapter).</p> <p>This button is active only after the calculation is done.</p>

6.2. Screening Flow

1. Turn ON the system
2. Press the screening button on the **Main screen** and enter the **SCREENING** stage.
3. Chose the desired **Intended Target Location** from the drop down menu.

If your target location does not appear in the drop-down Target Location menus, go back to the main menu. Create, and define your new target in the **Settings stage** in the **Target Location List Management** section (See the **SETTINGS** Chapter).

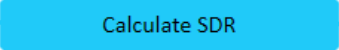
4. Press the **Calculate SDR** button to open the screening mode. 
5. Press the **Retrieval Dialog screen** button and retrieve Patient's Pre-operative CT scan. For guidelines regarding Pre-operative image acquisition see section **7.2, Pre-operative Image Guidelines**.



WARNING:

W062D

Ensure that the images of the CT series completely cover the skull: from one slice above the apex of the head to down below the brain, so that the system has adequate parameters of aberration correction of the acoustic beam (automatically) throughout the treatment, based on the specific skull characteristics.

6. The system will calculate the transducer's approximate template location based on the Target Location chosen. If needed, adjust the Transducer template position manually and tilt it in all orientations.
7. Press the Calculate button to receive the screening calculation results.
8. (Optional) Press the **Save** button to save the results to the DATABASE in the Screening Calculations Tab.
9. **Quit**

This page is intentionally left blank for double-sided printing.

7. PRE-PLANNING SESSION

The pre-planning session is a session that allows the user to perform some of the treatment planning steps before the start of the treatment. To increase time efficiency, the system saves the prepared data and allows the user to load it during the treatment.



WARNING:

W110

Regardless of the Planning session, always review the treatment candidate's pre-operative MR and CT images before scheduling a treatment to assess patient suitability.



NOTE:

N107D

The Pre-Planning Session can be loaded only before a sonication was performed.

7.1. Overview

A Pre-Planning Session can be performed prior to the treatment (on treatment day or on an earlier date):

- Create a **Planning Session** by loading or scanning high-quality pre-operative images for planning and reference during a treatment. This **Planning Session** can be saved and then loaded for reference during the actual treatment.

This also allows the user to pre-emptively perform tasks to streamline treatment efficiency. Typically, these tasks include:

- Loading CT images.



WARNING:

W065

Review CT images for clips, scars, unclosed sutures or anything that may affect the treatment plan.

- Loading of high-quality MR contrast images
- (optional) Load Tractography images
- NPR drawings
- Target delineation, assessment of patient and transducer positioning

- Analyzing and considering the techno-clinical parameters of the specific case



NOTE:

N035

The **Pre-Planning** session consists of roughly the same stages as the actual treatment and does not contain any extra functionality beyond the steps described above. All pre-planning tasks may also be completed as part of the treatment flow.

NOTE:

N036

During the **Pre-planning** session, there is no need for water to be filled in the interface or the Exablate Device to be connected to the MR in any way. The Device status is not relevant to a planning session, and the MR may be used as usual while a Planning session is in progress.

7.2. Pre-operative Image Guidelines

7.2.1. Guidelines for Pre-operative CT

Performing an Exablate treatment requires a CT scan of the patient's skull, which must conform to the following InSightec imaging guidelines:

- CT images should be reconstructed to be aligned with the AC-PC plane and orthogonal to the brain's mid-plane
- Non-aligned CTs are not fully supported by the system. They may not be reformatted and may lead to suboptimal algorithm performance. It is strongly advised to always acquire aligned CT scans for use in Exablate treatments.
- The range of axial images must cover the entire head from a few slices above the calvarium down to the skull-base, inclusive
- The CT should be acquired with an inter-slice resolution of 1mm (ST=1mm, Spacing=0)
- If the CT machine generation you are using does not allow the images to be acquired at thickness of 1mm, use higher resolution (E.g. 0.625mm) and then reformat the images into 1mm cuts
- The CT must be post-processed using one of the following **specific** types of 'Bone' kernels, validated for standardized SDR calculation:
 - For 'GE' CT scanner – 'BONEPLUS'
 - For 'Siemens' CT scanner – 'H60s', 'Hr60s', 'H60f', 'Hr60f', 'Hr56f'
 - For 'Philips' CT scanner – 'C'
 - For 'Toshiba' or 'Canon Medical Systems' CT scanner – 'FC30' (UE0 disabled)
- Use a symmetric matrix size of 512 X 512
- CT scans should be acquired with no contrast agents injected

CAUTION:

C024

The accuracy of SDR calculations for CT scans obtained using non-standard kernels is not validated and it cannot be reliably used to estimate patient suitability for treatment.

In addition to the CT, it is recommended (but not mandatory) to upload Pre-operative MR images of the patient to provide high-quality anatomic reference images. These may be loaded as part of a pre-planning session or brought in via the image retrieval dialog. (For guidelines regarding Pre-operative image acquisition see Section **7.2.2, Pre-operative MR imaging recommendations**)

7.2.2. Pre-operative MR imaging recommendations

Preoperative MR imaging is optional (as opposed to the mandatory CT), but highly recommended, in order to prepare a detailed pre-planning session which includes high quality anatomical imaging. Pre-operative scans should be scanned with a head coil, and can be T1 or T2 weighted, as per user's preference.

Images overlaid with additional information (e.g. tracts) can also be used provided, see Section 4.4, **Load and Visualize Tractography**.

Images can be acquired as:

- Three orientational (Axial/Sagittal/Coronal) series, already aligned along the relevant anatomy planes. Zero spacing is required, and it is recommended that these images have a slice thickness of 2.0mm and a resolution of 512 X 512.
- As a single volumetric series to be reformatted on the treatment workstation.

The single volumetric series should span the entire skull (from calvarium to base) with a slice thickness of 1-1.3mm and zero spacing to allow satisfactory quality.

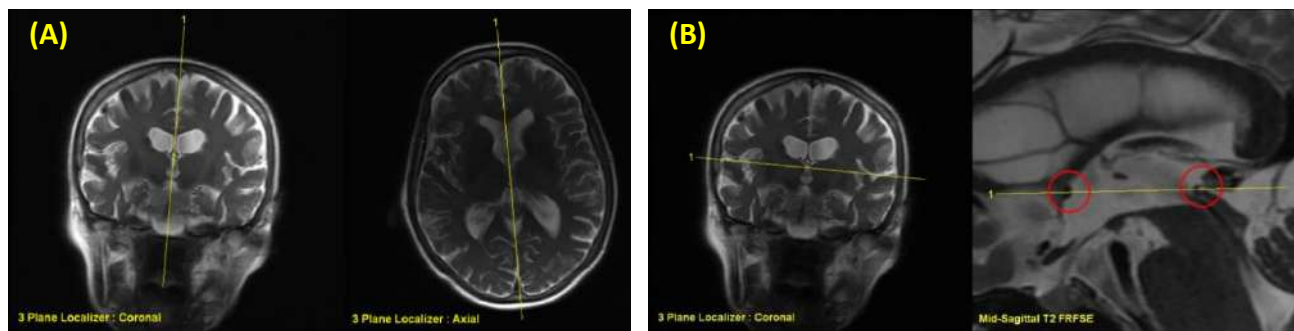

Figure 7-1: Planning Image Prescription Guides

A - Prescription Guidelines for the Sagittal Scan: Through AC-PC and Midline

B - Prescription Guidelines for the Axial Scan: Through AC-PC and Balanced on Coronal

7.3. Planning Session Procedure – With Pre-operative MR Images

7.3.1. Enter pre-planning Mode

To create a **Planning Session** in advance:

1. Turn ON the system.
2. Ensure that required pre-operative image data is available.

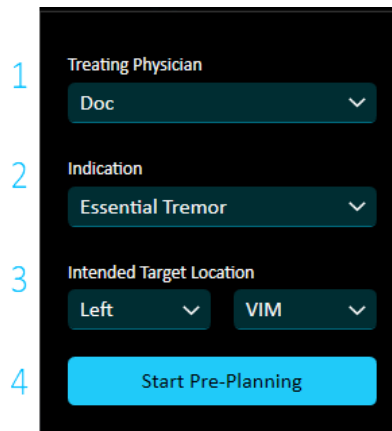

Figure 7-2: Pre-Planning Entrance Screen

No.	Name	Description
1.	Treating Physician	Field selection of username. The contents of this drop down will be managed by the “Username list management” area in settings.
2.	Indication	Drop down menu of the treating indication.
3.	Intended Target Location	Field to select the intended target location as well as brain side and targeted anatomy.
4.	Start Pre-Planning	Press this button to enter the Pre-Planning Mode. NOTE: The button will be unavailable if there are empty fields.

3. Press the **Pre-Planning** button on the main entrance screen. It can also be used to review and adjust previously prepared pre-planning files.
4. Fill the fields in the Pre-Planning entrance screen.
5. Press the Start Pre-Planning Button.

7.3.2. Planning Session Flow

The **PRE-PLANNING** stage is divided into 4 Sub-stages: Registration, AC-PC Plane, NPR review, Target and Save.

To edit a previously saved **Pre-Planning Plan** session (e.g. during a treatment), click the

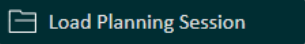
 **Load Planning Session**

button on the toolbox and select the relevant session from the **Planning Session Database** window. See Section **8.2.1, Load Planning Session**.

7.3.2.1. Pre-Planning Registration

1. Press the **Image retrieval** button and retrieve the patient's Pre-operative CT, MR and Tractography [optional] images. See Section **4.3, Image Retrieval Dialog**.
Once the images are loaded, the registration will be done automatically by the system.
2. Load images into all windows to review and approve the registrations.
3. Press the **AC-PC Plane** Sub-stage to proceed.

7.3.2.2. Pre-Planning AC-PC Plane

When entering the AC-PC Plane Sub-Stage, the AC, PC and Midline points are marked automatically.

4. Ensure AC-PC and midline markers are in place correctly.
If necessary, use the tools from the AC-PC Sub-Stage Toolbox (for more details see Section **8.7, AC-PC Plane**)
6. Approve the AC-PC by pressing the "Approve AC-PC" button. The transducer is automatically aligned to AC PC plane and selected target.
7. Press the **NPR Review** Sub-stage to proceed.

7.3.2.3. Pre-Planning NPR Review

When entering the NPR Review Sub-Stage, the **Sinus and Calcification Detection** is done automatically.

8. Review the CT and MR Images and add relevant NPRs if necessary (for more details see **Section 8.5.5, Drawing No Pass Regions (NPRs) Contours**).
9. Approve the NPR Markings.
10. Press the Target & Save Sub-stage to proceed.

7.3.2.4. Pre-Planning Target & Save

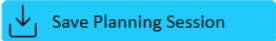
11. (Optional) Position the transducer on the relevant target by pressing this button: 
12. If needed, adjust the Transducer template's position by pressing on its overlays.
13. Place the target on the images, use the Targeting Toolbox (See Section **8.8, Targeting Substage**).
14. Press the '**Save Planning Session**' button to save the **Pre-Planning** session. 
 - After pressing save, you'll encounter three choices in a pop-up message:
 - **Save:** Confirms the preplan save without altering displayed images.
 - **Save and Clear:** Saves the preplan and clears displayed images for a clean workspace.
 - **Cancel:** Aborts the saving process, keeping everything unchanged.
15. **Quit**

7.3.3. Pre-Planning Session Data

The following data, which was drawn during the **Pre-Planning** session, will be saved, and loaded to the **Treatment Session**:

- No-Pass Regions (**NPRs**) – Manual, Auto-CT, Auto-Sinus and calcifications.
- Fiducials
- AC, PC points and Target – will be differently marked in **Treatment Session**
- CT-MR registration
- Measurements – lines, angles, areas
- Tracts names



NOTE:

Drawn measurements such as lines, angles and areas belong to the exact image plane on which they were drawn. As such they will be lost when the images are rebuilt (e.g. upon change to AC-PC plane).

N047

8. TREATMENT: PLANNING STAGE

This chapter describes the planning stage of an Exablate treatment and describes in detail its different stages and tools. The following chapters are ordered in the chronological order of a typical treatment.

8.1. Overview

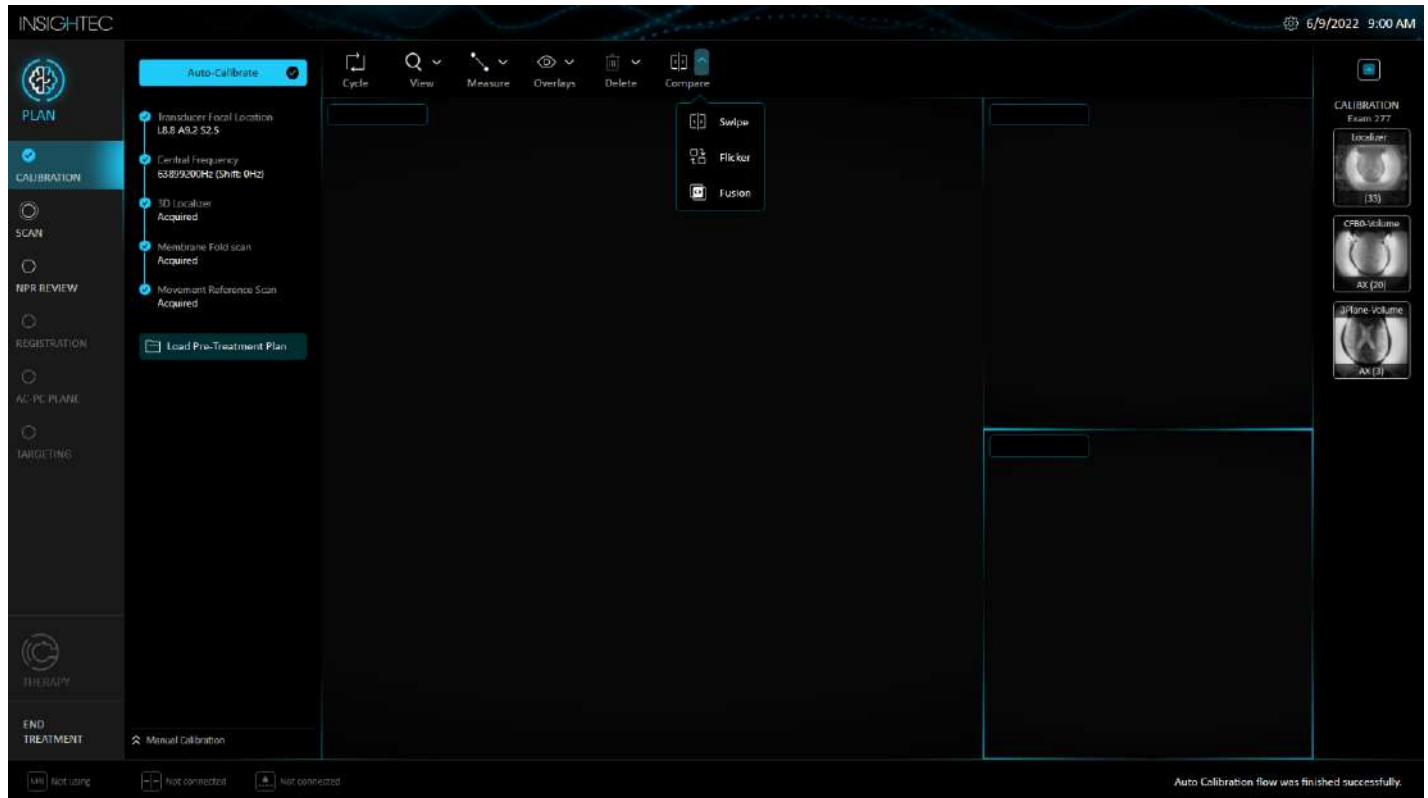

Figure 8-1: Planning Screen

The **Planning** stage is the first stage of the treatment, and it includes all the steps that shall be done to prepare the system for the sonications. For user convenience each step of the Planning phase was arranged into a sub-stage with the actions that operator must perform to proceed to the next step. The Planning phase consists of the following sub-stages: **Calibration**, **Scan**, **NPR approval**, **Registration**, **AC-PC**, and **Targeting**. After completing all these sub-stages, the user can proceed to the **Therapy** stage.



NOTE:

N037

During the **Planning** stage, there are several different treatment flows that can be executed by the operator. This chapter reviews a suggested treatment flow that covers all features available within this stage.



NOTE:

N038

It is suggested to keep the appropriate *Handbook* accessible near the system for a step-by-step checklist of a treatment's planning stage flow.



NOTE:

N108

Throughout the treatment process, automatic locking of the MRI interface is initiated by the software. Only consider unlocking it in case of an essential need or when facing abnormal conditions.

The operator is not obligated to follow the order of this suggested flow but must complete the following tasks to proceed the next stage:

1. **On the MR Console:** Register the Patient (**SIEMENS, PHILIPS**) or open a new Exam (**GE**).
PHILIPS MR: Make sure the Table usage is in "ignore" state.
2. Send the Exablate cradle to the center of the MR bore (**GE:** Landmark, **SIEMENS:** Iso-Center, **PHILIPS:** Lightvisor).
The MR cradle location indicator should show '0mm' on the screen while the second label on the cradle itself should be aligned with the one on the table.
3. Follow instructions in section **3.4.4, Begin Treatment Flow** to enter the treatment's PLAN stage.
4. Click on Auto-Calibrate to initiate the calibration process; See Section **8.3, Calibration Substage**.
5. Upload the Pre-Planning Session (if one exists) into the Exablate Neuro system. Otherwise load only Pre-Tx CT (mandatory).



NOTE:

N107D

The Pre-Planning Session can be loaded only before a sonication was performed.

6. Plan and acquire **MR planning images** (or alternatively plan images on the MR and scan the relevant series from the Exablate workstation).
7. Review and approve the NPR results from the **Automatic Sinus, Calcification and Membrane Folds Detection** algorithm based on the CT image values and Membrane Folds scan.
Review image to define/add sensitive areas that will limit or eliminate the acoustic energy from passing through them by drawing **No Pass Region Contours** on the CT or MR images.
8. Review the automatic **Registration** between the different sets of images in the Exablate workstation. Approve or adjust before proceeding. This process merges the coordinate sets of various images using a controlled registration algorithm. Non-registered images are not available for use in further steps.

9. Review and adjust the **AC-PC** reference points and midline as needed on the Intra-operative images. Approve before proceeding.
10. Determine the desired **Target location** and adjust the location of the transducer accordingly to match the transducer's natural focus to the target.
11. (Optional) Examine the **Movement Detection Reference** images that were taken automatically during the Calibration stage.

8.2. Loading Pre-operative Data

Performing an Exablate treatment requires a CT scan of the patient's skull.

In addition to the CT, it is possible to upload the patient's Pre-operative MR images to provide high-quality anatomic reference images. These may be loaded as part of a pre-planning session or brought in via the image retrieval dialog (for guidelines regarding Pre-operative image acquisition see section **7.2, Pre-operative Image Guidelines**).

8.2.1. Load Planning Session

A pre-planning session can improve treatment time management by allowing the user to perform various tasks ahead of the treatment, as well as provide high-quality reference pre-operative imaging.

Elements carried over from a pre-planning session into the treatment include NPRs (sinuses, calcifications), CT-MR registration, line and area measurements, AC&PC markings and a green fiducial marking pre-operative target placement (distinguished from intra-operative AC&PC and target).



NOTE:

N107D

The Pre-Planning Session can be loaded only before a sonication was performed.

For instructions on how to prepare a **Planning Session** prior to treatment, refer to the **PRE-PLANNING SESSION** Chapter.

1. To Load a ready-made Planning Session, press the '**Load Planning Session**' button. This can be loading during the initial steps of the planning session (Calibration, Scan, NPR Review and

Registration screens)

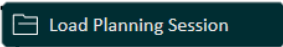

After performing a sonication, the '**Load Planning Session**' button will be disabled.

2. Select the previously prepared **Planning Session** you wish to upload from the open dialog box. Ensure that the date and name of the selected **Planning Session** is the correct one.

Load Planning session

Session Name	Patient ID#	Date	Indication	Target Side	Location	SEIR
Maria Azevharran Ruiz-Cortez Alfonso	4483577924	06 Jan 2021	Essential Tremor	Right	VIM	0.52
Jorge Smith	4583557168	12 Feb 2021	Essential Tremor	Right	VIM	0.48
Donald Finkdepeach	4592577924	06 Jan 2021	Essential Tremor	Right	GPI	0.33
Dianna Lowenstein Arroz	4483577924	06 Jan 2021	Essential Tremor	Right	VIM	0.58
Kenshoo Nakamura	4683577924	12 Jan 2021	Essential Tremor	Left	VIM	0.61
Maria Azevharran Ruiz-Cortez Alfonso	4483577924	06 Jan 2021	Essential Tremor	Right	VIM	0.68
Jorge Smith	4583557168	12 Jan 2021	Parkinsonian Tremor	Left	VIM	0.47
Donald Finkdepeach	4592577924	06 Jan 2021	Essential Tremor	Right	VIM	0.52
Dianna Lowenstein Arroz	4483577924	06 Jan 2021	Essential Tremor	Right	VIM	0.49
Kenshoo Nakamura	4683577924	12 Jan 2021	Essential Tremor	Right	VIM	0.41
Maria Azevharran Ruiz-Cortez Alfonso	4483577924	06 Jan 2021	Neuropathic Pain	Bilateral	VIM	0.39
Maria Azevharran Ruiz-Cortez Alfonso	4483577924	06 Jan 2021	Essential Tremor	Right	VIM	0.30

Dismiss Load Session

Figure 8-2: Example of Planning Session Database Screen



NOTE:

N042

If a previously prepared **Planning Session** has been loaded, its planning images and CT images will appear in the **Pre-operative** and **CT** sections of the **Image Thumbnail Bar**.



NOTE:

N043

Loaded Pre-operative images must be registered before use during a treatment.

8.2.2. Load Pre-operative images during a treatment

To load Pre-operative images during a treatment, open the Image Retrieval Dialog and retrieve the desired images from the hospital network or external storage. See Section **4.3, Image Retrieval Dialog**.



NOTE:

N044

All MR images belonging exams/patients which are not in the active exam will be recognized as Pre-operative.

8.3. Calibration Substage

8.3.1. Calibration Substage Purpose

In this sub-stage, the user shall acquire all the data needed for system calibration.

The calibration process includes:

- ✓ **Transducer Focal Location: Automatically track** and determine the transducer's home position and orientation relative to the patient's anatomy. B1 calibration is performed (if enabled in Profile).

NOTE: The term "B1" referenced throughout this manual is interchangeable with TG in GE systems and Drivescale in Philips systems.
- ✓ **Central Frequency:** Determine and fix the **Central Frequency** that will be used in the MR images throughout the treatment (to minimize imaging and thermal shifts).
- ✓ **3D Localizer scan,** serves as the basis for planning image acquisition.
- ✓ **Membrane Fold Scan,** assists with the automatic detection of membrane-fold-related NPRs
- ✓ **Movement Reference Scan,** assists in detecting patient movement during the treatment.
- ✓ **(Automatic Optional) Planning scan** that will be used later for defining AC-PC points, registration and targeting.

The auto calibration enables the user to sequentially perform all steps automatically by pressing on the Auto-Calibrate button.

All scans performed will be shown in the thumbnail bar under the calibration section.

For advanced calibration options, refer to the **SETTINGS** chapter.



NOTE:

In case the Auto-Calibration process is interrupted, it may be repeated by pressing the "Auto-Calibrate" button, or completed by prescribing the missing steps manually from the "Manual Calibration" tab at the bottom of the Calibration Substage Toolbox.

N096

8.3.2. Calibration Substage Required tasks

During the Calibration Substage, the user shall perform the complete calibration.

After the calibration is completed, the stage is considered as "completed".

8.3.3. Calibration Screen

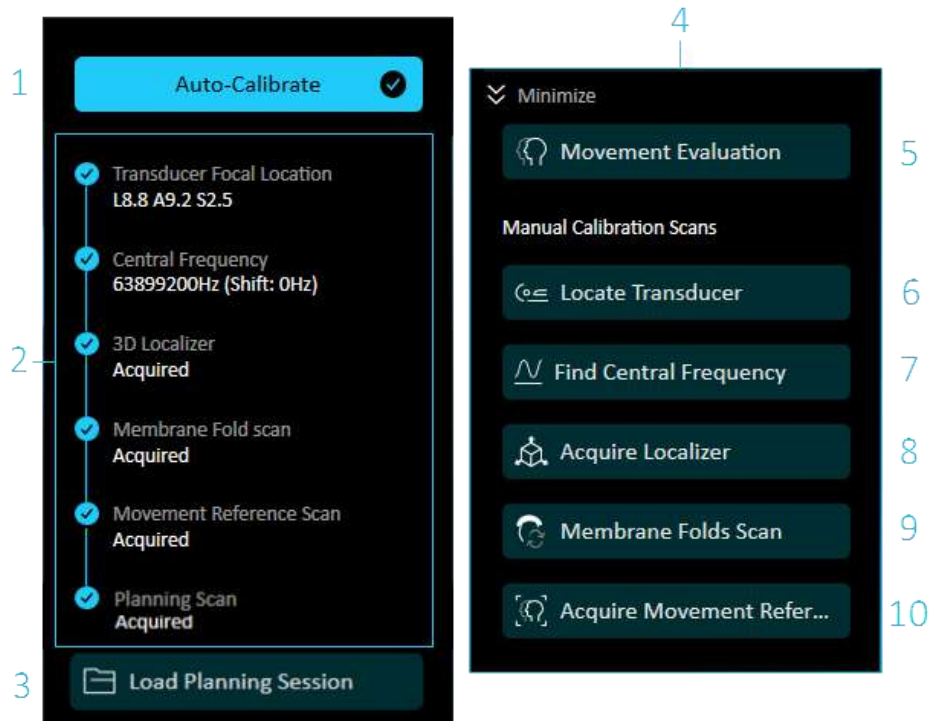

Figure 8-3: Calibration Screen

No.	Name	Description
1.	Auto-Calibrate Button	This button starts the automatic calibration process.
2.	Auto Calibration Bar	Displays the automatic calibration progress. See sections 8.3.4 – 8.3.9
3.	Load Planning Session Button	This button opens the Planning Session Database screen.
4.	Manual Calibration Pull-up Menu	Used for conducting a manual calibration process. Each step of the automatic calibration can be done independently by pressing its manual button in the Pull-up menu.
5.	Movement Evaluation	Press this button to enter the Movement Evaluation Mode (for details see dedicated Movement Evaluation section – 8.9)
6.	Locate Transducer	Press this button to manually calculate the transducer focal location.
7.	Find Central Frequency	Press this button to manually calculate the central frequency.
8.	Acquire Localizer	Press this button to manually acquire the 3D Localizer.
9.	Membrane Folds Scan	Press this button to manually acquire the membrane folds scan.

10.	Acquire Movement Reference	The system is taking reference images automatically. If reference images need to be taken again, press this button to start a new movement detection reference scan. Do not replace reference images without verifying that the patient has not moved unless performing a re-plan.
-----	----------------------------	--

8.3.4. Transducer Location Tracking

The **Transducer Location Tracking** is done automatically as part of the calibration process. The MR performs tracking scans to automatically detect the location of the transducer and cradle and subsequently update their focal coordinates on screen.

Once the tracking procedure has ended, the **Transducer Focal** coordinates are updated.

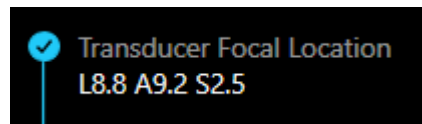

Figure 8-4: Transducer Focal Coordinates

It is possible to perform this step manually by pressing on “**locate Transducer**” button in the “manual calibration” section.



NOTE:

N045

Pressing the Transducer Tracking button updates the transducer location, eliminating the ability to return to the previous calibration, or to display the previous Transducer Focal coordinates.

For manual Transducer Calibration (Research optional) refer to its relevant section in **SETTINGS** Chapter.

8.3.5. Scan and Detect MRI Frequency

Detecting the correct value of the MRI Central Frequency prior to the treatment can reduce thermal imaging shifts during sonications.

This feature enables you to scan and detect the MRI Central Frequency to be used for the scans throughout the treatment. The results will appear on screen. This procedure will be performed automatically by the system during the Auto-Calibration process.

The Scan is automatically repeated if the first scan results exceed the threshold.

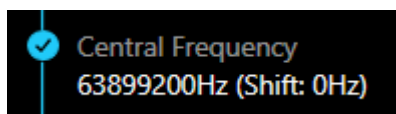

Figure 8-5: Detected MRI Frequency Frame

It is possible to perform this step manually by pressing the “**Find Central Frequency**” button in the “manual calibration” section.

**WARNING:**

W112

Monitoring anatomy images during sonications and switching sonication frequency directions enables the monitoring and management of frequency-related shift.

8.3.6. 3D Localizer Scan

A **3D Localizer** scan is prescribed and acquired automatically as part of the auto-calibration process. This serves as the basis for planning image alignment.

It is possible to perform this step manually by pressing the “**Acquire Localizer**” button in the “manual calibration” section.

The 3D Localizer image series are available for display in ‘Calibration’ and in the ‘Planning Scan’ sub-stages.

8.3.7. Membrane Fold Scan

The membrane folds scan is a short scan which assists with the automatic detection of membrane-fold-related NPRs. It is done automatically during the Auto-Calibration process.

It is possible to perform this step manually by pressing the “**Membrane Folds Scan**” button in the “manual calibration” section and from the NPR substage.

If the scan is repeated, the previous membrane folds images and NPR markings are replaced.

8.3.8. Movement Detection Scan

The **Movement Detection Scan** assists in detecting patient movement during the treatment.

Reference Movement Detection images are automatically acquired by the system during the Auto-Calibration process.

It is possible to perform this step manually or acquire new movement Reference images by pressing the “**Acquire Movement Reference**” button in the “manual calibration” section.

(Optional) During the planning stage, patient movement can be evaluated at the calibration stage by pressing the “**Movement Evaluation**” button.

Refer to Section **8.9, Movement Evaluation**.

8.3.9. Planning scan (automatic optional)

For added convenience, a predefined planning scan similar to detailed in the "Scan Substage" section below can be integrated to the end of the automatic calibration process at the start of the planning stage. Once the scan completes, the "Scan Substage" will be marked as completed.

To activate this feature, navigate to the Settings > Profile section, see section **10.3.1 Planning Scans** and toggle ON the "Auto Acquire Scan" option.

8.4. Scan Substage

8.4.1. Scan substage purpose

In this sub-stage, the user acquires the planning intra-operative images that will be used later for defining AC-PC points, registration and targeting.



CAUTION:

C026D

Re-acquire images if at any point the quality or alignment of the planning images are not satisfactory.



NOTE:

N109

Certain orientations or frequency directions may be disabled or restricted for different scan types within the system. This limitation is applicable across various scan modes including Thermometry, Intraoperative Scans, Lesion Evaluation, and Parallel Imaging (PI).

8.4.2. Scan Substage Required Tasks

During this substage, the user is required to choose the preferred scan type and scan the intra-operative scan. To complete the Scan substage a minimum of one Volumetric sequence or three planar scans (one in each orientation) is required.

8.4.3. Scan Screen

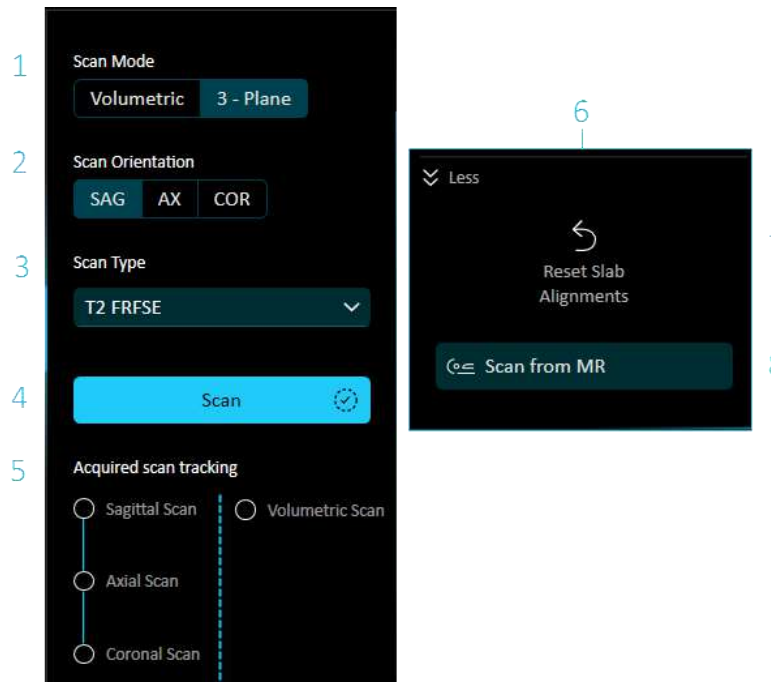

Figure 8-6: Scan Screen

No	Name	Description
1.	Scan Mode	<p>Enables the user to choose the scan type prior to treatment and generate MR series for planning purposes. Two scanning modes are available for the user to select as follows:</p> <ul style="list-style-type: none"> • Volumetric - scans and creates one volumetric MR series. a single volumetric scan is sufficient for a treatment flow. • 3-plane - scan a short acquisition. All three orientations (axial, coronal and sagittal) are required for a treatment flow.
2.	Scan Orientation	Used for selecting the scan orientation: axial, coronal or sagittal. (For some sequences select orientations may be disabled)
3.	Scan Type Drop-down Menu	Used for selecting the scan protocol to be acquired. The protocols are preset and adapted to the site. For advanced options refer to the SETTINGS Chapter.
4.	Scan Button	This button starts the planned scan.
5.	Acquired Scan Tracking	Displays which scan type was acquired: volumetric or 3-plane.
6.	Pull Up menu:	
7.	Reset Slab Alignments	Reset planar scan slabs to be aligned with MR axis. Can help in case the scan slabs become misaligned. Available only in 3-Plane mode.
8.	Scan from MR	<p>Press this button to run the planning images scan, after preparing it on the MR.</p> <ul style="list-style-type: none"> • GE: Press the Auto Pre-Scan button on the MR workstation. Wait until the MR completes the pre-scan. SIEMENS/PHILIPS: Adjust the series. • Press the Scan Prepared Series button on the Exablate Neuro workstation; the planned scan will start to run on the MR. <p>When the scan ends, the new scanned MR series will appear in one of the Exablate Neuro workstation image strips.</p> <p>NOTE: This button enables the running of scans generically for all different scan orientations.</p>

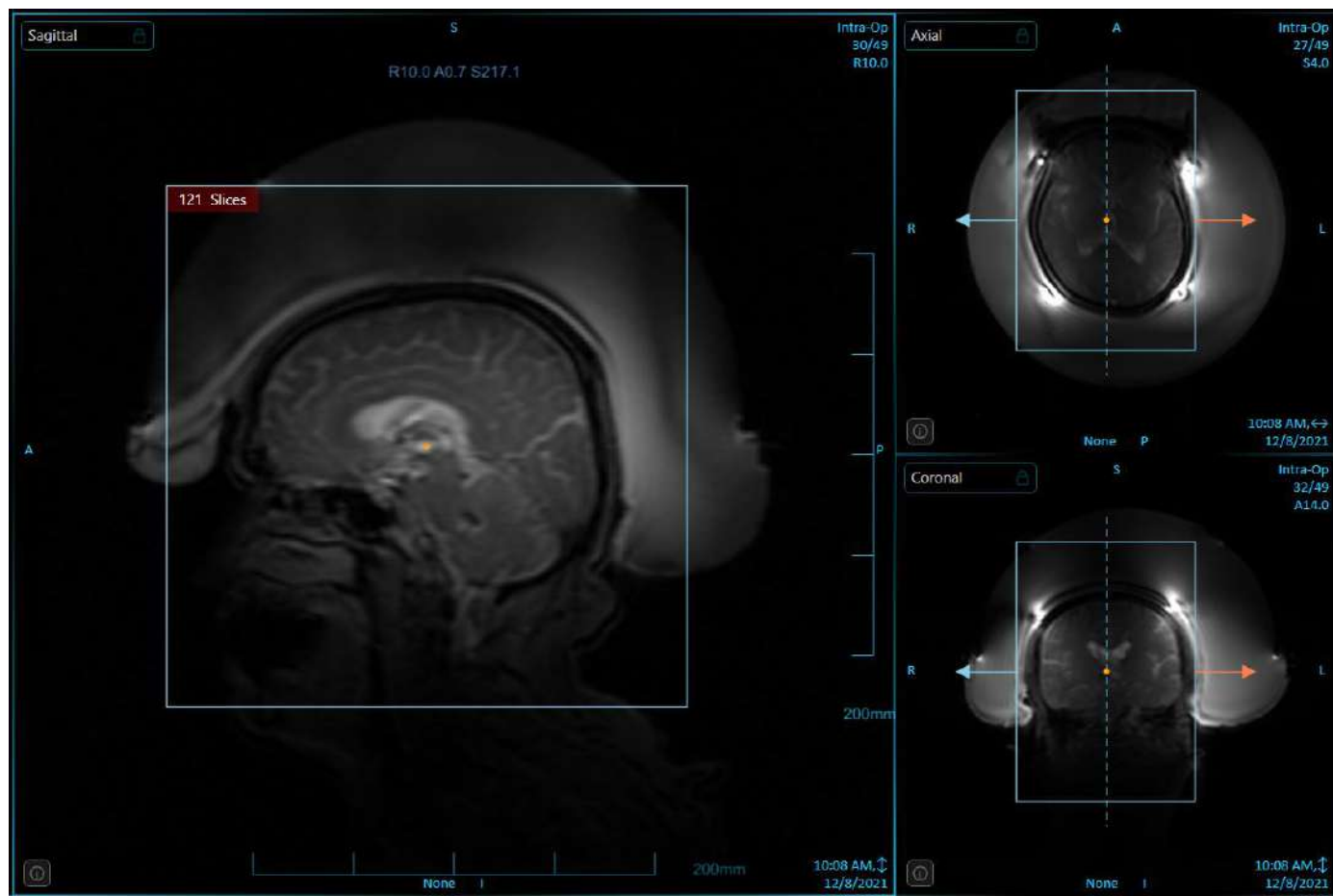

Figure 8-7: Example of Scan Planning

NOTE: Only the 3D localizer and planning scans will be available to be loaded during the scan substage.

8.4.4. Parallel Imaging Overview and Guidelines

8.4.4.1. PI Overview

In Exablate WS9.01, planning and thermometry sequences utilizing Parallel Imaging or PURE capabilities are supported. These sequences are superior in terms of image quality and/or acquisition and phase times. PI based imaging does require Patient Membranes equipped with head coils.

On certain configurations (e.g. GE DV26), PI/PURE image acquisition requires a manual calibration scan in order to be used. See subsection **8.4.4.3**

Attempting to acquire a PI/PURE planning sequence without a calibration will result in an informative pop-up message, while PI thermometry options will not be available until a calibration is performed.



NOTE:

N049

The Manual PI Calibration scan is only necessary when working on certain GE systems.



NOTE:

N051

The PI calibration requirements and limitations may vary per MRI vendor and SW. Contact your InSightec representative for further details.

8.4.4.2. PI in the Profiles Screen

Since calibration is required for PI sequences, they are not displayed in the Profiles screen's thermometry default drop down menus. To reveal PI thermometry options toggle "Show PI Thermometry Scans" to ON. Acquiring a PI Calibration Scan

See Subsection **10.3.7 Calibration (Advanced)**.

8.4.4.3. PI Calibration Scan

In order to perform a manual PI calibration scan:

- Enter the Settings screen while in treatment/DQA mode
- Verify the "Enable Parallel Imaging PI" toggle is set to "ON"
- Ensure the MRI is ready and press "Perform PI Calibration scan". A short scan will be performed.

PI/PURE planning sequences may now be acquired, and PI thermometry sequences will be made available.

8.4.5. Intra-Operative Image Acquisition from the Software

The planning and acquiring of the MR Planning images can be done from the Exablate Neuro software.

The treatment region of interest around the target will be covered by planning images of all three orientations.



CAUTION:

Re-acquire images if at any point the quality or alignment of the planning images are not satisfactory.

C026D

Two scan modes are available:

- Volumetric Scan
- 3-Plan Scans

8.4.5.1. Acquire the Volumetric or 3-plane Scan series

Volumetric scan mode will produce one scan that covers the whole head.

1. Enter the SCAN Plan's substage.
2. Chose **Volumetric / 3-Plane** scan mode.
3. Chose Scan Orientation.
4. Chose Scan Type from drop down menu (e.g. 3D Bravo for volumetric). Scan types are predefined.
5. Adjust the scan range of images. Ensure that the range of images covers the entire skull anatomy.
6. Press the **scan** button to perform the scan with the optimal **Central Frequency** previously determined.
7. For 3-Plan scan mode: perform steps 2-7 for the two other orientation scans.
8. When the MR has completed scanning this series, the set of images will be retrieved automatically and displayed on the **thumbnail** of the Exablate Neuro workstation.
9. Review the images to confirm:
 - That the patient is correctly positioned such that the target is in a treatable position.
 - Carefully check each image to verify that the patient has not moved during imaging.
 - Verify that both Anterior and Posterior Commissures clearly appear on the images.
 - Verify that the actual **Scanning Range** meets the expected one.

8.4.5.2. Define the Scanning Range

A planning scan is defined by its:

1. Location - placement of the FOV as illustrated by the blue frame on the image window with the prospective scan's orientation
2. Scan width (or range) - the volume of the scan, as determined by its thickness, spacing, and number of slices (as shown on the FOV)
While scan sequences whose name is followed by "(SLAB)" have a pre-set scan range, other sequences' scan range may be adjusted by pressing on the arrows next to the slab and dragging to adjust it. Note that maximal and minimal slice number values apply for volumetric and planar scans
3. Tilt - for planar scans only, the user may tilt the scan slab by pressing and moving the slab midline or the "rotate slab" icon.
4. To customize the Scanning Range, the operator can drag the graphic line object to enlarge or reduce the coverage area on the image strips.



NOTE:

N054

It is recommended to select the minimal number of slices required to fulfill the clinical needs, to minimize the expected scanning duration.



NOTE:

N055

Re-scanning an orientation already acquired via the **Scan From MR** button is recommended only if the angle of the relevant orientation has been altered.

5. When all series have been uploaded to the Exablate Neuro workstation, review the images to confirm that:
 - The target to be treated is clearly identifiable.
 - The patient is correctly positioned so that the target is in a treatable position.
 - Carefully check each image to verify that the patient has not moved during imaging.
 - Verify that the actual **Scanning Range** meets the expected one.



NOTE:

N056

- The range of planning images must cover both the AC and PC landmarks

8.4.6. Intra-Operative Image Acquisition: Manual Acquisition (Based on MR User Interface)

The following options are alternatives to acquiring the planning images from the Exablate workstation, based on MR User Interface.



CAUTION:

C026D

Re-acquire images if at any point the quality or alignment of the planning images are not satisfactory.

8.4.6.1. Option A: Acquire all images from MR workstation via 'Scan from MR'

Plan the required planning image sequences using the MR workstation and acquire them from the Exablate workstation via the **"Scan From MR"** button. This will ensure the use of the same MRI Central Frequency as for all other scans throughout the treatment, while retaining active Cradle Tracking data, and allowing the use of planning image protocols not integrated into the WS.

1. Prepare a planning series on the MR. While it is recommended to base the scan on the MR on the pre-built protocols, the user may employ other protocols and parameters (while keeping a slice thickness of 2.0mm or less, zero spacing, and a 512 x 512 matrix).



NOTE:

N050D

Not all scan types are supported.

When prescribing the series:

- Select sequences that clearly show the region of treatment and include the entire skull anatomy.
- Ensure that the range of images covers the desired region of treatment
- Ensure at least one image intersects both the AC and PC anatomical structures.
- If needed, adjust scan parameters such as slice thickness and FOV, to optimize image quality.

For an example of image alignment see **below**:

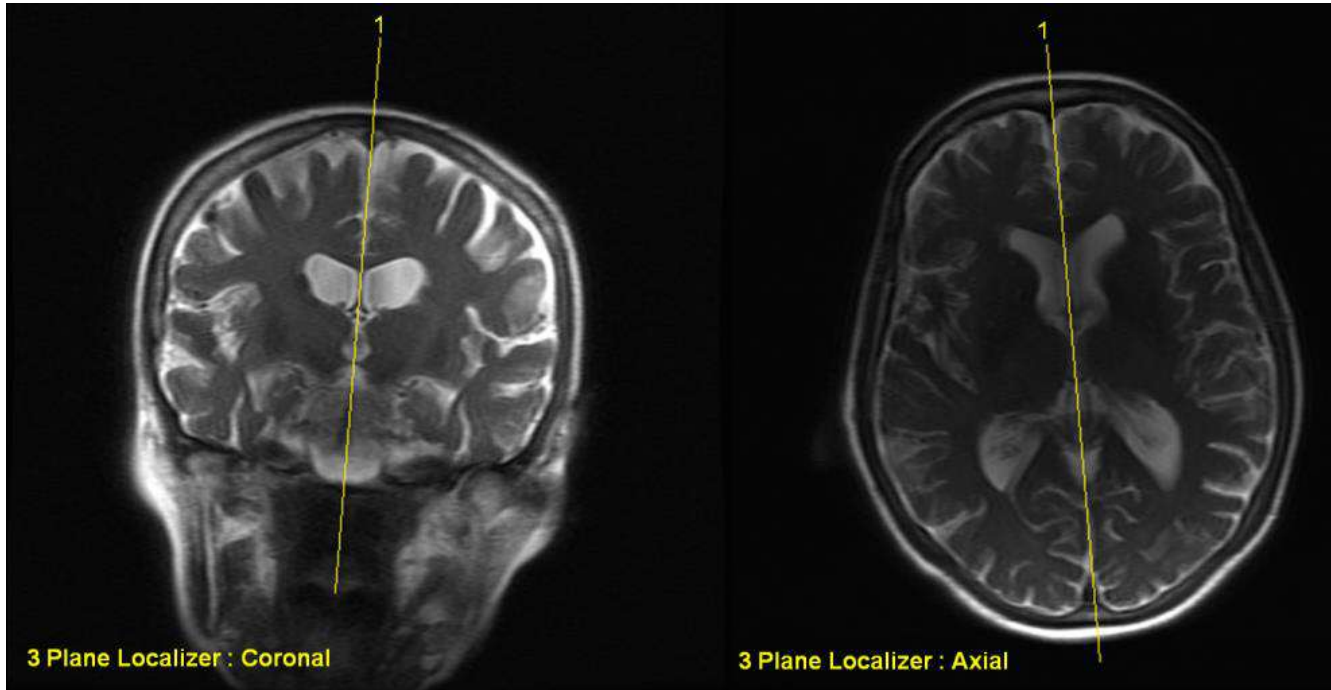

Figure 8-8: Prescription guidelines for Sagittal scan: Through AC-PC and midline

2. When the scan is ready to be scanned, press the **Auto Pre-Scan** (GE) button on the MR workstation or Adjust the series (SIEMENS/PHILIPS).
3. Then press the **Scan from MR** Button:

☰ Scan from MR

4. Pre-determined MR Central Frequency values will be used automatically.
5. As each of the scan series completes, it will automatically populate to the Exablate Neuro workstation and displayed.
6. After acquiring each scan, confirm that:
 - The target to be treated is clearly identifiable.
 - The patient is correctly positioned so that the target is in a treatable position.
 - Closely examine each image and verify that there are no air gaps visible along the entire acoustic path from the transducer to the target.
 - Carefully check each image to verify that the patient has not moved during imaging.

8.4.6.2. Option B: Load intra-operative images from the Image Retrieval Dialog

Loading the planning images using the Image Retrieval dialog may be useful if a series is erroneously deleted or the flow involves a non-human research setting.



WARNING:

W069

This Option is **not recommended** in a clinical setting, as Cradle Tracking will NOT be performed.

1. Press the button to access the Image Retrieval Dialog.
2. Locate the active exam (you may search by name/date/exam number or simply press search to retrieve all available exams)
3. The newly acquired scan series will appear on the **Exam Selection List**.
4. Drag or double click the thumbnail to select the series you would like to upload for retrieval.
5. To change the selection, click cancel and select a different set of images.
6. Press **Load** to upload the images.
7. Selected series will appear in the thumbnail bar in the relevant section in the main screen (MR Series from non-active exams may only be loaded as pre-operative images). For more instructions, see Section **4.3, Image Retrieval Dialog**.
8. After loading the images, confirm that:
 - The target to be treated is clearly identifiable.
 - The patient is correctly positioned so that the target is in a treatable position.
 - Closely examine each image and verify that there are no air gaps visible along the entire acoustic path from the transducer to the lesion.
 - Carefully check each image to verify that the patient has not moved during imaging.

8.5. No Pass Region (NPR) Substage

8.5.1. NPR Substage Purpose

The NPR Substage enables the user to draw the NPR markings on CT and MRI images required for the treatment planning. NPR markings denote areas through which no energy will be transmitted or areas on which the energy density should be followed throughout the treatment. NPR contours should be drawn on all relevant images.

After drawing these contours, the system will automatically update the beam path to each sonication spot and will prevent the beam from passing through the NPR contours.

8.5.2. NPR Substage Required Tasks

During the NPR Substage, the treating physician shall be required to review and approve NPRs (both for MR and CT).

After approving, the stage is considered as “completed”.

8.5.3. NPR Review Screen

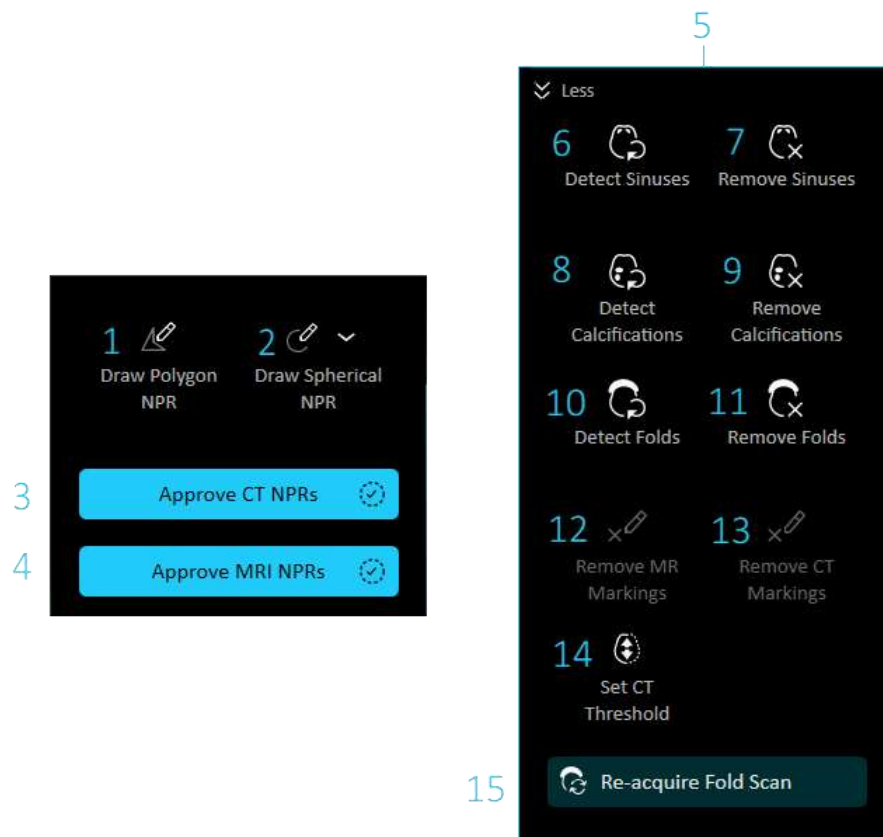

Figure 8-9: NPR Review ToolBox

No.	Name	Description
1.	Draw Polygon NPR	<p>Define NPR (No Pass Regions) as follows:</p> <ol style="list-style-type: none"> 1. Press on the Draw Polygon NPR button; draw NPR contours around the sensitive tissues. 2. If required, continue to define the NPR on additional slices. <p>Move the NPR by pressing it and dragging. Delete the NPR by pressing it and then pressing the Delete button.</p> <p>Polygonal NPRs drawn on adjacent slices before releasing the tool will be merged into a single 3D object.</p>
2.	Draw spherical NPR	Press this button to place spherical NPRs on the image. Choose the desired sphere volume from the drop-down menu.
3.	Approve CT NPRs Button	Press this button to approve the reviewed CT markings on the CT images. Pressing this button is mandatory for proceeding to the registration stage.
4.	Approve MRI NPRs Button	Press this button to approve the reviewed NPR markings on the MR images. Pressing this button is mandatory for proceeding to the registration stage. The button is available only after acquisitions of the Membrane Folds Scan.
5.	Pull Up Menu:	
6.	Detect Sinuses Button	Press this button to automatically detect the sinuses contours in the pre-operative CT image.
7.	Remove Sinuses Button	Press this button to remove the sinuses contours (previously automatically detected) from the pre-operative CT images.
8.	Detect Calcifications Button	Press this button to automatically detect calcifications contours in the image on the pre-operative CT.
9.	Remove Calcifications Button	Press this button to remove the calcification contours (previously automatically detected) from the pre-operative CT images.
10.	Detect Folds Button	Press this button to automatically detect the membrane fold contours on the Membrane Fold Scan images.
11.	Remove Folds Button	Press this button to remove the membrane fold contours (previously automatically detected) from the Membrane Fold Scan images.
12.	Remove MR Markings Button	Press this button to remove the Manual MR NPR markings (previously manually marked) from all the MR images.
13.	Remove CT Markings Button	Press this button to remove the Manual CT NPR markings (previously manually marked) from the pre-operative CT.
14.	Set CT Threshold Button	<p>Press this button to adjust the CT image segmentation, based on bone and air thresholds:</p> <ul style="list-style-type: none"> ● Select the CT image to display it in the selected image window. ● Press this button to change the thresholds of bone and air: <ul style="list-style-type: none"> ❖ Drag the mouse up to increase and down to decrease the bone threshold.

		<ul style="list-style-type: none">❖ Drag the mouse left to increase and right to decrease the air threshold. The change is automatically reflected in all the CT images.
15.	Re-acquire Fold Scan Button	Press this button to repeat the MR Fold scan. The scan is automatically followed by a fold NPR calculation. NOTE: The existing membrane fold images and markings will be overridden.

NOTE: Only CT, MR (Intra-Operative, Pre-operative IF REGISTERED) and membrane folds images are available for loading in the thumbnail bar in the NPR review substage.

8.5.4. Automatic Calcification and Sinus Detection

The system automatically detects the presence of air cavities (sinuses and membrane folds) as well as any calcified structures. This computation is performed using the properties of the CT as well as the membrane fold scan.

Upload the CT scan prior or during this 'NPR Review' step via the **Image Retrieval Dialog**.

The system will identify on the CT images and the Membrane Folds scan:

- **Sinuses** - Air cavities in the skull
- **Calcifications** – Areas of bright tissue within the brain, typically calcified structures.
- **Membrane Folds** – Air cavities formed by the folding of the membrane around the patient's head. Folds are detected by the membrane fold MRI scan done in the Calibration stage.

The system will automatically mark these detected regions with NPRs. Calcifications, sinuses and membrane folds are treated as different entities. Therefore, selecting 'Delete All' will only delete the selected entity's type.

When in the NPR Review stage, make sure to Review the results to verify correct marking of the NPRs and manually complete the NPR contours for full coverage, if required.

If needed (e.g. after a large transducer movement), re-acquire a new Fold Scan to improve the fold marking. The new scan will overwrite the previous Fold Scan and the previous fold NPR marking will be lost.

When loading a **Pre-Planning Session**, the CT and Sinus markings are carried over. Re-running the automatic Calcification and Sinus Detection algorithm will overwrite the previous auto-markings.

Membrane fold marking can only be done during treatment.

At the end of the Review stage, press '**Approve CT NPRs**' and '**Approve MRI NPRs**' to proceed to the next stage.



NOTE:

Calcification markings can be individually or completely deleted independently from Sinus markings

N063



WARNING:

The **Automatic** algorithm can only **assist** the operator in marking the sinuses, calcifications and membrane folds. Therefore, after running this feature, pay strict attention and review all the CT images to ensure that:

W073

- All sinuses, calcifications and membrane folds were identified and marked correctly
- No regions were marked unnecessarily
- After each running of this feature, you must review the computation results

8.5.5. Drawing No Pass Regions (NPRs) Contours

When there is a need to prevent the beam path from passing through sensitive regions, **NPR (No Pass Regions)** contours should be drawn on all relevant images.

After drawing these contours, the system will automatically update the beam path to each sonication spot and will prevent the beam from passing through the NPR contours.



WARNING:

W074

Ensure that you are using both the MR and CT images to carefully identify sensitive regions and mark them with **NPRs**. Particularly, gaps and air folds in the beam path (e.g. calcifications, sinuses, and air cavities)



WARNING:

W075

Drawing **NPR** contours may be used to prevent injury to the patient during treatment. The treating physician should identify and draw the regions where the beam should not pass through.



WARNING:

W076

Make sure to evaluate spot shape and alignment when modifying NPRs substantially.

Examine the sensitive anatomical structures on the images, and draw their NPR contours as follows:

1. Select an imaging strip where the regions that the beam should not pass through are best identified.
2. Press the '**Draw Polygon NPR**' to draw polygonal NPR contours around where sensitive tissues appear in the images. While the tool is active, polygons drawn on adjacent slices will be merged.
3. Press the '**Draw Spherical NPR**' button for drawing spherical NPRs around round sensitive areas. Spheres can be chosen with 1, 2 and 4mm diameters. The larger spheres will normally cover multiple MR image slices.



NOTE:

N064

NPRs can be modified only on their original drawn images.

For CT image segmentation, the thresholds can be changed using the "Set CT Threshold button".

8.6. Registration Substage

8.6.1. Registration Substage Purpose

The purpose of the registration substage is to align all the various imaging "worlds" to the same coordinate system in order to facilitate targeting, focusing and planning.

8.6.2. Registration Substage Required Tasks

To complete the registration substage, the user must register the intra-operative MR images to the reference series (typically the CT).

Note that registration of pre-operative images is not-mandatory, but non-registered images may not be used in subsequent treatment stages.

8.6.3. Registration Screen

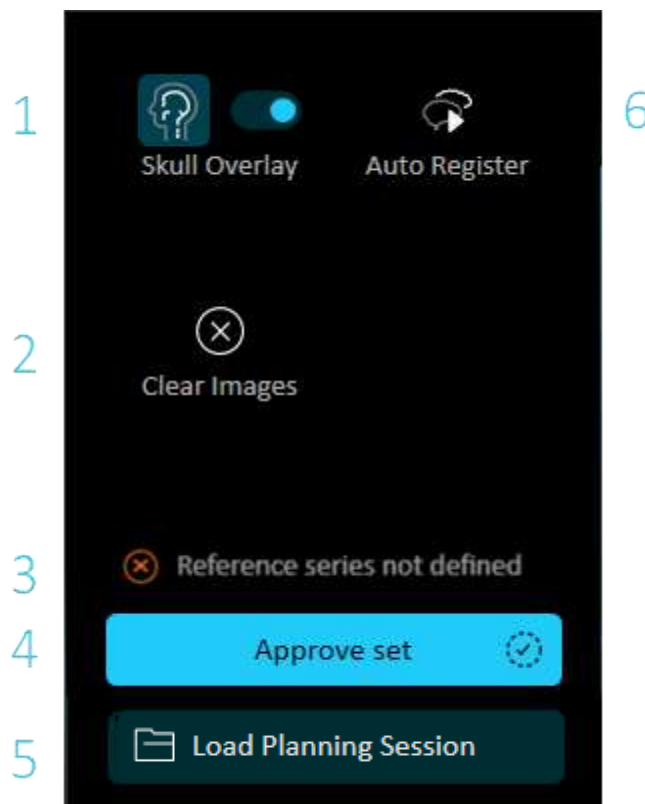

Figure 8-10: Registration Toolbox

No.	Name	Description
1.	Skull Overlay Button	Press this toggle button to display or hide the skull overlay, Same as the one in the overlays menu, duplicated to Registration substage for convenience.
2.	Clear Images Button	Press this button to clear all images from the image windows. This will cancel the ongoing registration for the selected series.
3.	Reference Set	Shows if a series has been set as reference. This is required in order to perform registration. In a standard flow, the reference set is the CT series. See Section 8.6.5.1, Registration reference .
4.	Approve Set Button	Clicking this button approves the reviewed registration. Pressing this button is mandatory for proceeding to the AC-PC Plane stage.
5.	Load Planning Session Button	Press this button to open the Planning Session Database screen.
6.	Auto Register Button	Press this button to activate the automatic registration process. The algorithm will run from the last state available.

NOTE: Only Planning Intra-operative and Pre-operative images will be available to be loaded from the thumbnail bar in the Registration substage.

8.6.4. Registration Substage Thumbnail Image Annotations

	<p>Semi-registered (Registration substage only) – Denotes images for which an auto-registration result has been calculated. When dragged into the windows, the registration results shown are accurate.</p>
	<p>Available for loading – When a series without the “Semi-Registered” annotation is loaded during registration, the results can be inaccurate. Make sure to review the registration before approving the set.</p>
	<p>Registration Approved (Registration substage only) – Images for which registration has been reviewed and approved by the treating physician</p>
	<p>Reference Set (Registration substage only) – Series set to which the system performs a registration with all the other Intra-operative series automatically.</p>

8.6.5. Performing a Registration

8.6.5.1. Registration reference

The system selects one series situated in the thumbnail bar as the reference for the registration. The reference series is marked with the following symbol on it: 

The system performs a registration between the reference series and all the other Intra-operative series automatically.

In a standard flow, the reference series is the CT. The following flow is described in accordance. If no reference is selected registration is not possible and an indication appears above the (disabled) approve registration button

(Not recommended in a standard flow) It is possible to choose another series as a reference by clicking “Set as reference” on the relevant series.

8.6.5.2. Registration flow

The registration is initiated automatically in the background and shown at the beginning of this step and aligns all images in the thumbnail bar:

Pre-operative CT to Pre-operative MR (in the planning stage or in a pre-planning session) and intra-operative MR images.

The registration is shared between all intra-operative images (including calibration images).



NOTE:

N060

In a standard flow, the reference series is the CT. The flow is described in accordance.

1. Review the registration and verify that the registration results accurately match the CT and MR images. Use the Compare tool described in the **TOOLS & OVERLAYS** Chapter.
2. If required, manually adjust the registration between the two series. Adjust iteratively on all three MR orientations until the CT segmentation mask fully corresponds to the anatomy on the MR images, use the Cycle Tool to bring the orientation you want to the main window. Select the green square to move the CT frame, and the lever to rotate it, or press to perform discrete movement/rotation.



WARNING:

W070

Inaccuracy in the registration may generate sub-optimal computation of focusing correction and skull heating temperatures. Verify that the registration results accurately match between CT and MR images.

3. Approve the registration for the set of images by pressing “Approve Set”. The series that were registered to the reference will be marked by the following symbol:  and image windows will be cleared.



NOTE:

N041

Only registered and approved sets of images will be available in the next steps of the treatment.

8.7. AC-PC Plane

8.7.1. AC-PC Substage Purpose

The AC-PC Plane substage enables the user to automatically (or manually) define the required anatomical landmarks for target definition on the MR images: the Anterior Commissure (AC) marker coordinates, the Posterior Commissure (PC) marker coordinates and midline coordinates.

8.7.2. AC-PC Substage Required Tasks

An approved placement of the AC and PC points (and Midline alignment) are required for completion of the AC-PC substage.

8.7.3. AC-PC Plane Screen

In this stage the system displays the AC-PC-ML on dynamically reformatted images and provides tools to evaluate and edit the AC-PC-ML locations.

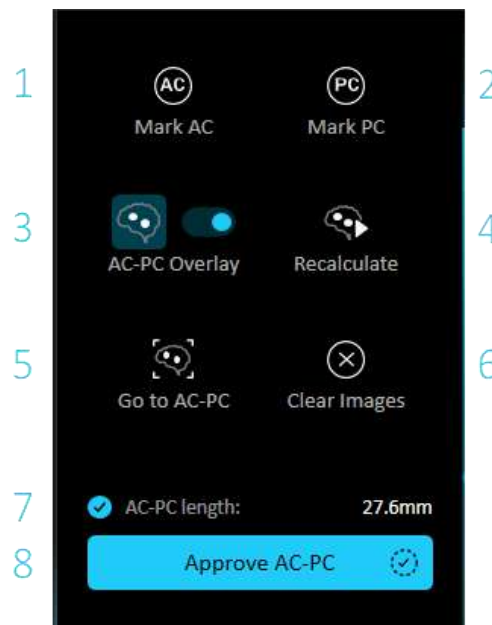

Figure 8-11: AC-PC Plan Toolbox

No.	Name	Description
1.	Mark Anterior Commissure	<p>Press this button to mark the Anterior Commissure on the MR images and to enable the system to align all planning images with the AC-PC plane.</p> <p>To use this marking tool:</p> <ul style="list-style-type: none"> ● Press on the Mark AC button. ● Navigate through the images to find the exact location of the Anterior Commissure. <p>Place the marker on the MR image where the center of the Anterior Commissure is clearly seen.</p>
2.	Mark Posterior Commissure	<p>Press this button to mark the Posterior Commissure on the MR images to align all planning images with the AC-PC plane.</p> <p>To use this marking tool:</p> <ul style="list-style-type: none"> ● Press on the PC Marker button ● Navigate through the images to find the exact location of the Posterior Commissure. <p>Place the marker on the MR image where the center of the Posterior Commissure is clearly seen.</p>
3.	AC-PC Overlay Toggle	Press this button to display or hide the AC-PC points overlay from the image. It is the same as the one in the overlays menu, duplicated for convenience.
4.	Recalculate Button	Press this button to automatically recalculate the AC and PC points on the MR images. In case of a messy reformat misalignment, pressing this button will reset the images and AC PC.
5.	Go to AC-PC Button	Press this button to center the displayed strips on the slice containing AC and PC (Axial, Sagittal) or the central slice between them (Coronal).
6.	Clear Images Button	Press this button to clear all images from the display.
7.	AC-PC length display	Displays the distance between the AC and PC points on the MR images.
8.	Approve AC-PC Button	Press this button to approve the reviewed AC-PC and midline points on the MR image. Pressing this button is mandatory to proceed to the Targeting stage.

NOTE: Only the registered and reference series will be available in the thumbnail bar in the AC-PC substage.

8.7.4. Place the AC-PC and Midline Markers

The system reformats the MR series to create three perpendicular series. This allows for precise finetuning of the AC-PC plane in order to produce three intra-operative planning image series. It determines and

demarcates the AC, PC and midline points on the intra-operative images created by the reformat. The Midline plane will automatically intersect both the AC and PC landmarks.

When entering this step, the main image window will display the reconstructed images and present the AC and PC marks. The midline point is visible on the Coronal orientation. Use the cycle tool to bring the coronal orientation to the main image window.

Changing the AC-PC and midline markers will change the reformatted series on the screen to produce anatomically aligned images. Each movement of one of the markers will simultaneously change the image.

1. Review the **AC and PC Graphic Object** points and ensure that they are aligned with the anatomical Anterior and Posterior Commissure structures on the MR images.
2. If needed, adjust the **AC and PC Graphic Object** points to their correct anatomical positions by dragging them or by using the “Mark AC” and “Mark PC” buttons.
3. Navigate through the coronal reconstructed images to ensure that the **Midline Graphic Object** (marked automatically) is aligned with the anatomical midline of the brain on the MR images. The midline **does not have to run through anatomical midline, but parallel to it.**
4. If needed, adjust the **Midline Graphic Object** point accordingly to its anatomical position. To rotate or change the midline plane, move the **Midline point** to better represent the midline.
5. Approve the AC, PC and midline points by pressing “**Approve AC-PC**”. This is mandatory before proceeding to the Targeting phase.

**WARNING:**

W072

The **Automatic** algorithm is meant to **assist** the operator in marking the AC, PC and Midline points. Please review the proposed locations following every auto calculation thoroughly prior to approval to ensure that all items (AC, PC and Midline) are aligned with their anatomical brain structures.

8.8. Targeting Substage

8.8.1. Targeting Substage Purpose

The Targeting substage is the last one as part of the planning phase. In this stage the user shall be able to plan and add his target (spot) based on previously prepared data from previous substages.

To determine the target, the user may perform measurements on the anatomical images of the patient, or type in coordinates relative to the RAS coordinate system or the location of the PC marker.

In a standard flow, the **ACPC 90 Angle** tools can assist with this. The **AC-PC Angle** is particularly useful for VIM targeting as it will create a 90° line extending perpendicularly from the AC-PC line at a location of 25% anterior to the PC (25% of the AC-PC length) and 14.0mm in length. The default will place this line to the right, targeting the patient's left hemisphere.

The AC-PC 90 angle measurement can appear upon the entrance of the Targeting substage, depending on selected target definitions in the target entrance screen list, refer to the **SETTINGS** Chapter.

8.8.2. Targeting Substage Required Tasks

During the Targeting Substage, the user shall:

- Define a valid target and perform the stop sonication test.
- If necessary, adjust manually the transducer location and press update transducer location.
- Finalize the treatment plan and the target location.

After finalizing, the stage is considered as “completed”.

8.8.3. Targeting Screen

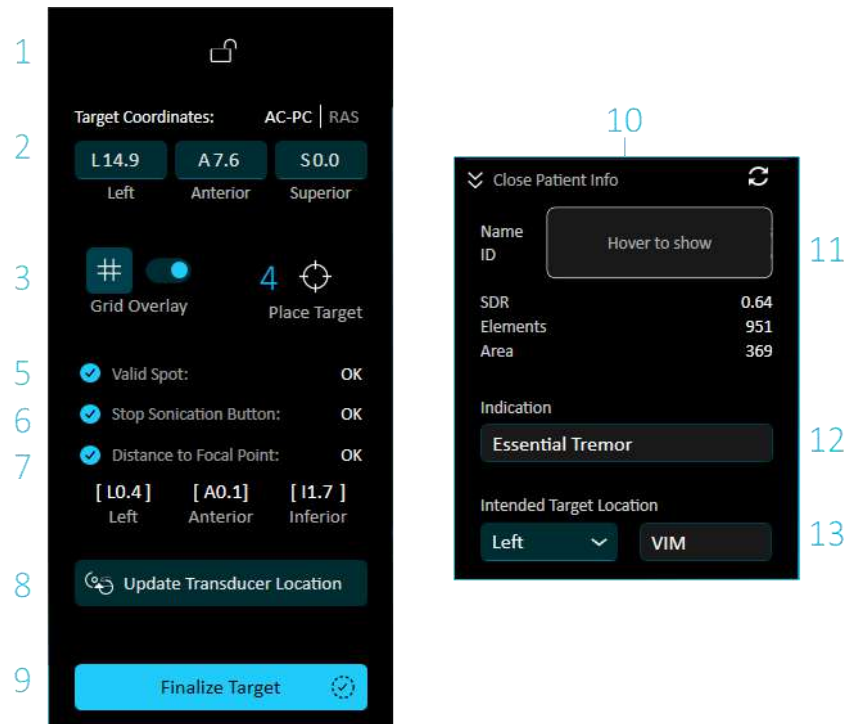

Figure 8-12: Targeting Substage Toolbox

No.	Name	Description
1.	Unlock/Lock Target coordinates	Press this button to unlock and change target coordinates. Coordinates should be locked when not undergoing editing.
2.	Target Coordinates Field	Displays the target in RAS or AC PC coordinates. See Section 8.8.4.1, Typing Target Coordinates.
3.	Grid Overlay	Press this toggle button to show/hide the targeting grid (only displayed on images “Reformatted by AC-PC Coordinates”).
4.	Place Target	Press this button to place your target. This tool sets the target coordinates on the MR image by dragging it to the relevant location. When dragging it over the MR image, the Target Coordinates field, the AC-PC I RAS field and the Distance from Focus to Target field will change in response to the tool movement. The colors of both the Place Target icon and the above-mentioned fields changes. See Section 8.8.4.5, Colors.
5.	Valid Spot Indicator	Indicates that the selected sonication target location is valid for the treatment.

6.	Stop Sonication Indicator	Indicates if the patient presses the stop sonication button to validate its operational status.
7.	Distance from Focus to Target	Displays the transducer focus coordinates relative to the target coordinates.
8.	Update Transducer Location Button	Press this button to recalculate the new transducer location after being manually moved by the operator to a new position. The Transducer overlay will be adjusted accordingly on the MR image.
9.	Finalize Target	Press this button to Finalize the sonication target location and finalize the treatment plan session. Pressing it will "lock" the target. Changing the target will invalidate this approval. Pressing this button is mandatory for continuing to the therapy stage.
10.	Patient Info Pull Up Menu (See Section 8.8.68.8.6, Patient Information):	
11.	General Patient Info	When hovering on the "Hover to show" field, it displays the patient's name and ID, SDR, Transducer's ON Elements, and Available Skull Area.
12.	Indication	Displays the patient's indication
13.	Intended Target Location	Shows the brain side (modifiable) and the targeted anatomy in the brain

NOTE: Only the planning intra-operative images will be displayed and be able to be load on the thumbnail bar in the targeting substage.

8.8.4. Target Determination

There are two different ways to place the target on the Intra-operative)

1. Placing the target manually on the image (See **Placing the Target Manually**)



NOTE:

N061

The target may only be placed on intra-operative MR planning images. To review target location on pre-operative images, make use of "Compare mode".

8.8.4.1. Typing Target Coordinates

The **Target Section** of the Targeting screen enables the user to type in the target location in two different coordinate systems:

- **RAS:** These are coordinates relative to the coordinate system of the MR.
- **AC-PC:** These are coordinates relative to coordinate system defined by the placement of the AC, PC, and midline markers. Its origin (0,0,0) is at the PC.

(**R**: Right (+), **L**: Left (-), **A**: Anterior (+), **P**: Posterior (-), **S**: Superior (+), **I**: Inferior (-))

To switch between the coordinate systems, press on AC-PC or RAS accordingly, see image below.

Once coordinates have been entered in one system, the other will be automatically updated, and a target will appear on the screen. The target on the screen changes automatically for every change in the coordinates.

RAS and AC-PC coordinates can be seen at any point when hovering on the icon in the main image window.

At the end of the target determination, lock the coordinates to avoid any unwanted changes.

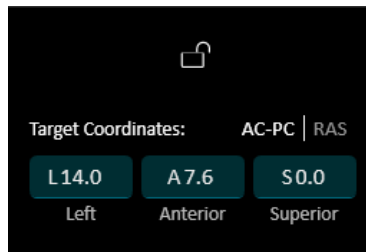

Figure 8-13: Target Coordinates Section

The target marker will change its color according to its validity and will be marked as a Valid or Unvalid spot in the Target section on the screen. See Section 8.8.4.5, **Colors**.

8.8.4.2. Placing the Target Manually

Press the **Place Target** button and then place the marker by pressing the left mouse button on top of the desired anatomical location in the main image window. If needed, use the Grid Overlay for precision when placing target coordinates (Grid Overlay displays in AC PC Coordinates).

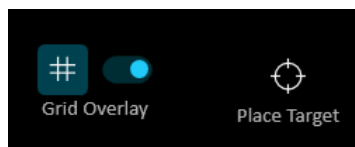

Figure 8-14: Manual Target Placement Tools

The target marker will change color according to its validity and will be marked as a Valid or Invalid spot in the Target section on the screen. See Section 8.8.4.5, **Target Validity Colors**.

8.8.4.3. Adjusting the Target

Regardless of the target placement method, the target may be updated either by dragging it with the mouse or by adjusting the coordinates manually (the other coordinate set will be automatically adjusted). Unlock the target in order to adjusting it. Remember that since the RAS and AC-PC axes are oriented differently, a 1mm adjustment in one may not translate to 1mm in the other.



NOTE:

Placing a new target will overwrite the previous target.

N052

8.8.4.4. Spot Distance to Focal Point

The distance from the target location to the focal point of the transducer has an impact on the effectiveness of the treatment. Make sure the spot distance to transducer focus is validated by the system and within the steering limits.

Criteria for a valid distance to focal point:

- Target coordinates are within an area of **less than a 5mm** radius around the focal point of the transducer
- One of the translation vector coordinates of the spot is within a **5 to 15mm radius** of the Transducer Focus. If the distance is above this threshold, the location is considered less effective but still treatable and the target will be marked in yellow (🟡).

Invalid distance to focal point:

- One of the translation vector coordinates is **more than 15mm** from the Transducer Focal point, and is out of the treatment envelope. The spot is considered non-treatable and will be marked in red (🔴).

A valid spot is necessary to proceed to treatment. To establish an optimal location for energy delivery, a manual movement of the transducer may be necessary, refer to **Section 8.8.5, Aligning the Transducer Focal Location to Target**.

8.8.4.5. Target Validity Colors

3 different possible spot color states indicate the validity of the spot and treatment parameters.

- Green Spot (🟢): The spot and treatment parameters are valid. You can proceed with the treatment.
- Yellow Target (🟡): The spot considered less effective but still treatable.

One of the treatment parameters is not valid. (e.g., energy density / spot distance from transducer focus is above threshold). Review the treatment parameters to improve treatment efficiency.

- Red Target (🔴): Non-treatable spot (e.g. spot parameters are not valid/distance from target etc.).

A valid spot is necessary to proceed to treatment.



NOTE:

When the target is not green, the reason will be displayed on the bottom right of the screen.

N070

8.8.5. Aligning the Transducer Focal Location to Target

While the **Target Center** is the center of the exact anatomical location of the desired region to be treated, the geometrical center of the transducer (**Transducer Focus**) is the optimal location for energy delivery. Therefore, to ensure optimal energy delivery efficiency, the **Target Center** and **Transducer Focus** should be

in the same location. This means that the Transducer location should be adjusted using the positioning slider mechanism.

The Target Section includes the **Distance to Focal Point** translation vector. It specifies the direction and required distance [in mm] the transducer needs to be moved to have the **Transducer Focus** aligned with the desired **Target Center** location.

The translation vector changes its color to align with the target marker (white, yellow, and red).

Adjust the transducer location as indicated by the vector (for specific instructions, refer to Section 0,



Figure 3-26: Philips Landmark Accessory

Mechanical Positioning of the Transducer) and run a Transducer Tracking Scan to ensure that the distance between the Transducer Focus and Target is satisfactory.



NOTE:

The translation Vector will be shown and updated on the Front End Unit Screen inside the MR suite. N062



WARNING:

The **Automatic Tracking** procedure must be repeated after any change of the mechanical positioning unit location by pressing this button. W071

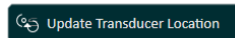

8.8.6. Patient Information

Patient information is accessible from the from Patient Info section in the targeting screen. See image below. It includes the following:

- The Name and ID of the patient as introduced in the MR exam. Slide the pointer on the area to reveal the information.
- Treatment information like the SDR, Elements on and treating area
- Indication as indicated at the entrance of the planning stage
- Intended target Location. The Hemisphere side can be modified and has an impact on spot validity.

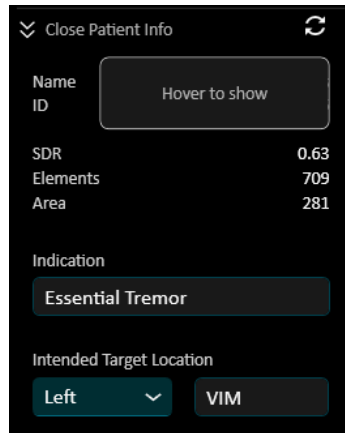

Figure 8-15: Patient Information



NOTE:

Values with squiggles (e.g. SDR: ~0.65) indicate that the results may have changed since last calculated. Refresh the information to update values.

N081D

8.8.7. Stop sonication button check

Before advancing to **Therapy Stage**, confirm that both the patient and the supporting staff have been instructed in the use of the **Stop Sonication** button, and that the patient is holding it and understands how to operate it.



WARNING:

The patient, supporting clinical staff and operator should be instructed to stop the sonication if the patient feels pain, heat or any unexpected sensation and/or if operator recognizes patient's distress, wrong spot location or shape or undesired temperature behavior.

W080



NOTE:

The system will not proceed to **Treatment Stage** without testing the **Patient Stop Sonication** button.

N065

8.8.8. Advancing to Therapy Stage

Before proceeding to therapy stage, check the following:

- The spot is valid

- ✔ Stop Sonication button was checked and pressed by the patient.
- ✔ Distance of the target location to focal point is valid

Press the **Finalize Target** button to finalize the target determination.

Press the **Therapy** button on the main toolbar to advance to the next stage in the treatment.

8.9. Movement Evaluation

Although the patient head is fixed to the transducer with screws, small patient head movements may still occur. As a safety mechanism, an imaging-based patient movement detection algorithm tracks patient movement.

To assess the findings of the movement detection algorithm there is a dedicated screen, the MD evaluation screen, where the operator can observe and compare the MD images.

Reference Movement Detection images are automatically acquired by the system during the Calibration process.

User can enter the movement detection evaluation screen from the following places:

- Calibration substage
- Therapy define substage
- Therapy review substage
- Replay screens
- Movement detected message



WARNING:

W078

Ensure that you monitor patient movement during sonications using the real-time anatomy images to confirm no movement; use the **Automatic Movement Detection** feature as an additional advisory element.



WARNING:

W079

Monitoring patient movement is important to assure accurate sonication targeting.

Monitor the patient movement vector before the sonication and the skull overlay location on anatomical images during the sonication. In case of detected movement go to the movement evaluation screen.

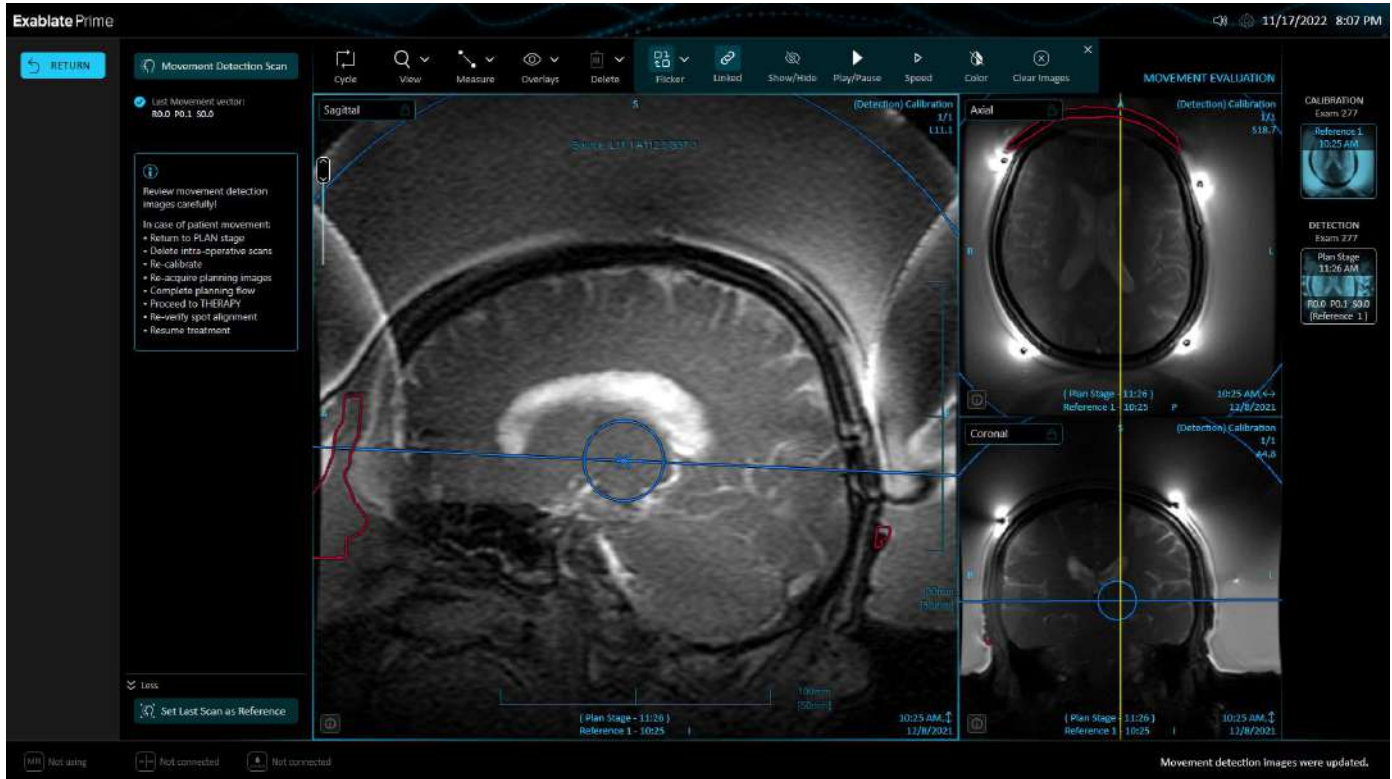

Figure 8-16: Movement Evaluation Screen

After entering the Movement Evaluation Screen, the Flicker Tool will be in play mode. Refer to the Compare tools in the **TOOLS & OVERLAYS** Chapter.

8.9.1. Movement Evaluation Toolbox

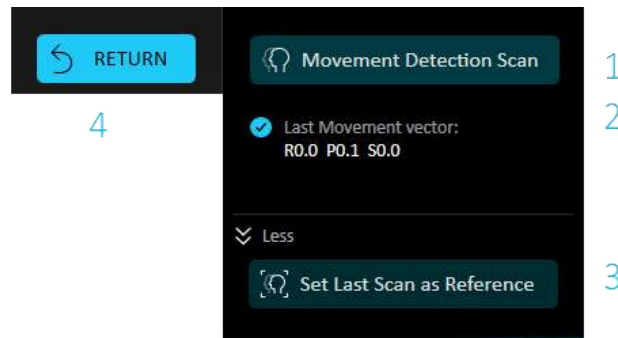





Figure 8-17: Movement Evaluation Toolbox

No.	Name	Description
1.	Movement Detection Scan Button	At any stage during the treatment, movement detection can be done to verify a patient’s position. Press this button to start a new movement detection scan. The system will calculate the movement and inform the user if a significant movement was detected.
2.	Last Movement Vector	The last movement vector shows the system’s calculation of patient movement between the reference and the last movement detection scan.
3.	Set Last Scan as Reference Button	Press this button to set the last movement detection images taken as reference for movement evaluation in the future. They will be added to the thumbnail bar as a new reference, see Section 8.9.2, Movement Evaluation Thumbnail Image Annotations. <div style="display: flex; align-items: center;">  <div> <p>WARNING: W077</p> <p>Setting the last scan as reference should only be done if no patient movement has occurred. In case of real patient movement re-plan the treatment.</p> </div> </div>
4.	Return	Press this button to exit the movement detection evaluation screen.

8.9.2. Movement Evaluation Thumbnail Image Annotations

	<p>Movement detection Reference images (Movement Evaluation screen only) – Denotes the Movement detection reference image number and scan time. If a new reference image is performed and set, the reference number will grow by one. REFERENCE images are found in the CALIBRATION section of the movement evaluation screen's thumbnail bar.</p>
 	<p>Movement detection images (Movement Evaluation screen only) – The thumbnail image denotes:</p> <ul style="list-style-type: none"> • The Movement detection image belonging stage (plan stage or in therapy, the sonication number). • Time of the scan. • Original movement detection vector result. • The reference the movement was calculated for. <p>DETECTION images are found in the DETECTION section of the movement evaluation screen's thumbnail bar</p>

8.9.3. Movement Evaluation

When the **Movement Detection** option is turned ON in settings, the system will automatically perform movement detection imaging and analysis of every sonication, and will alert if the movement is greater than 1.5 mm. If a movement is detected, the evaluated direction of movement will be displayed (point in three axes represents the direction vector). If the estimated movement is above one mm, check movement detection images to verify the movement and open the **Movement Evaluation Screen**.



WARNING:

W083

An automatic algorithm is used for movement detection. This algorithm is designed to assist the operator to identify movement. However, the movement detection option does not replace the operator and does not relieve the operator from responsibility to properly identify movement.

8.9.4. Tracking Movements Manually

At any stage during the treatment, patient position and movement can be detected based on the **Anatomy Real-Time** images (during the delivery of sonications). To assist in manually tracking the patient's position, fiducial markers can be added on the anatomical images at distinct edges as reference markers that will appear on the real-time images (should be intersected with the thermal map plane). Monitor the fiducial markers during the treatment to facilitate the detection of patient movement.

To add these fiducial markers:

1. Select a relevant Planning Image or Movement Detection Reference image in the Main Image window.
2. Add new fiducials from the Measure tool.
3. Point and press on the Selected Main Image window to create a marker on the anatomical edges of relevant structures.
4. Press again at another location to add as many fiducial markers as desired.
5. Repeat in all image orientations. If required, move or delete the fiducials.

8.9.5. Steps in case of patient movement

In case of detected patient movement, re-plan the treatment by the following steps:

- Return to Plan stage
- Delete intra-operative scans from the thumbnail bar.
- Re-calibrate in the calibration substage.
- Re-Acquire planning images in the Scan Substage.
- Complete planning flow as described in planning stage.
- Proceed to Therapy stage.
- Re-verify spot alignment.
- Resume treatment.

This page is intentionally left blank for double-sided printing.

9. TREATMENT: THERAPY STAGE

9.1. Overview

The **THERAPY** stage is the stage where sonications are prescribed and treatment is delivered to the patient. The sonication cycle is comprised of three distinct substages:

- **Definition (Define substage)**
- **Sonication (Sonicate substage)**
- **Review (Review substage)**

It also includes the following sub-modes:

- **Pre-sonication**
- **Online sonication replay**
- **Movement Detection and Evaluation screens**
- **Treatment Report**

The transitions between these substages are controlled by the sequential progression of sonication steps. Pressing the **Sonicate** button triggers substages **Define** and **Sonicate** to appear. Once a sonication ends, the user is automatically transferred to the **Review** substage. Upon approval or rejection of the sonication results, the user is returned to the **Define** substage to plan for the next sonication, if needed. This progress along the treatment and the substages of the Therapy is displayed in the **Navigation Bar**.

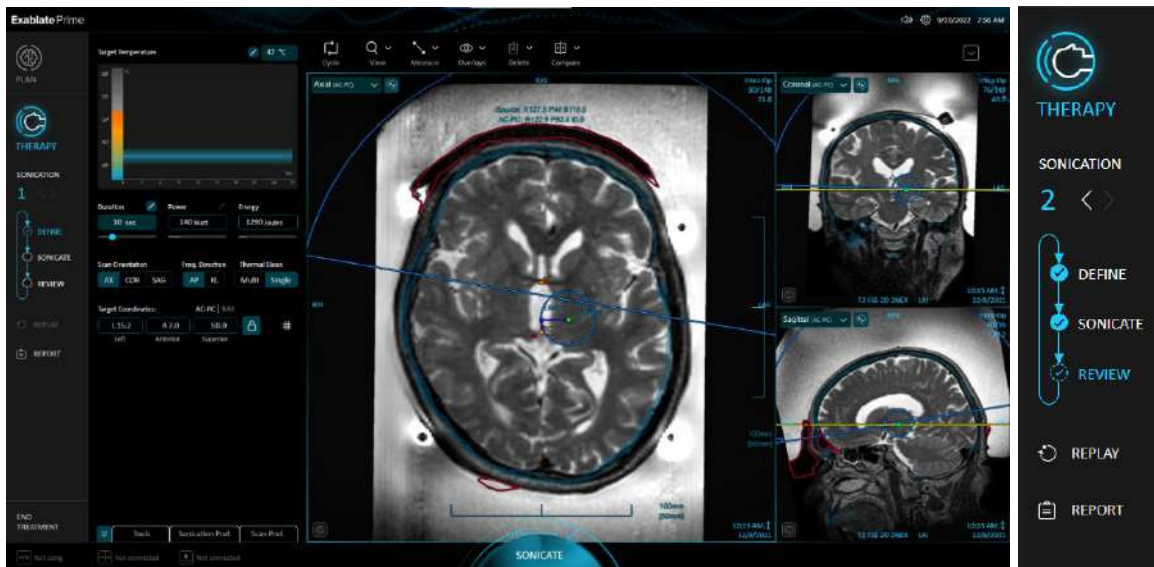

Figure 9-1: TREATMENT: THERAPY STAGE

The screen layout of the **Therapy** substage differs slightly from the **Plan** substage. The **substage toolbox** area is wider, at the expense of the **image thumbnail bar** which is now collapsible.

The **image windows** and **image viewer toolbar** retain their functionality.

Note that loading images via the **image retrieval dialog** is not possible while in the **Therapy** stage.

Navigation back to the **PLAN** stage is only possible from the **Define** substage.

9.1.1. Therapy Stage Navigation Bar

No.	Name	Description
1.	PLAN	Return to PLAN stage. (Available only during the DEFINE substage)
2.	THERAPY	Indicates that THERAPY is the active stage
3.	Current sonication index	The sonication number about to be performed. Type the index of a previous sonication to observe it in REPLAY mode.
4.	Sonication chevrons	Click to navigate to previous sonications (enters REPLAY MODE).
5.	Therapy substage indication	Passive element: Indicates the currently active Therapy stage substage. (In the accompanying image: DEFINE substage)
6.	REPLAY button	Entering REPLAY MODE will display the previous sonication. (Not available during the SONICATE substage)
7.	REPORT button	Open the treatment Report for observation. (Not available during the SONICATE substage)
8.	End Treatment	Unlock and press to End the treatment and return to the Entrance Screen. (Available only during the DEFINE substage)



Figure 9-2: Therapy Stage Navigation Bar

9.1.2. Therapy Stage Image Thumbnail Bar and Image Types

The button on top of Thumbnail Bar no longer opens the image retrieval dialog, rather, it serves to expand and collapse the Image Thumbnail Bar. It can be collapsed and expanded by pressing the button.

Non-registered images are not displayed in the Image Thumbnail Bar during the Therapy substage.

A new image type called THERMAL images is shown during the SONICATE and REVIEW substages, as well as in REPLAY mode.

These are images acquired during the sonication or images derived from them:

- Anatomy: Images meant to emphasize anatomy, a different image for each sonication phase
- Thermal: Temperature representation: the brighter a pixel, the hotter it is.
- PRF Anatomy: This method of image reconstruction is based on published work¹. A single PRF Anatomy image per thermal slice is created at the conclusion of a sonication and is therefore available for viewing in the REVIEW substage and in REPLAY mode.

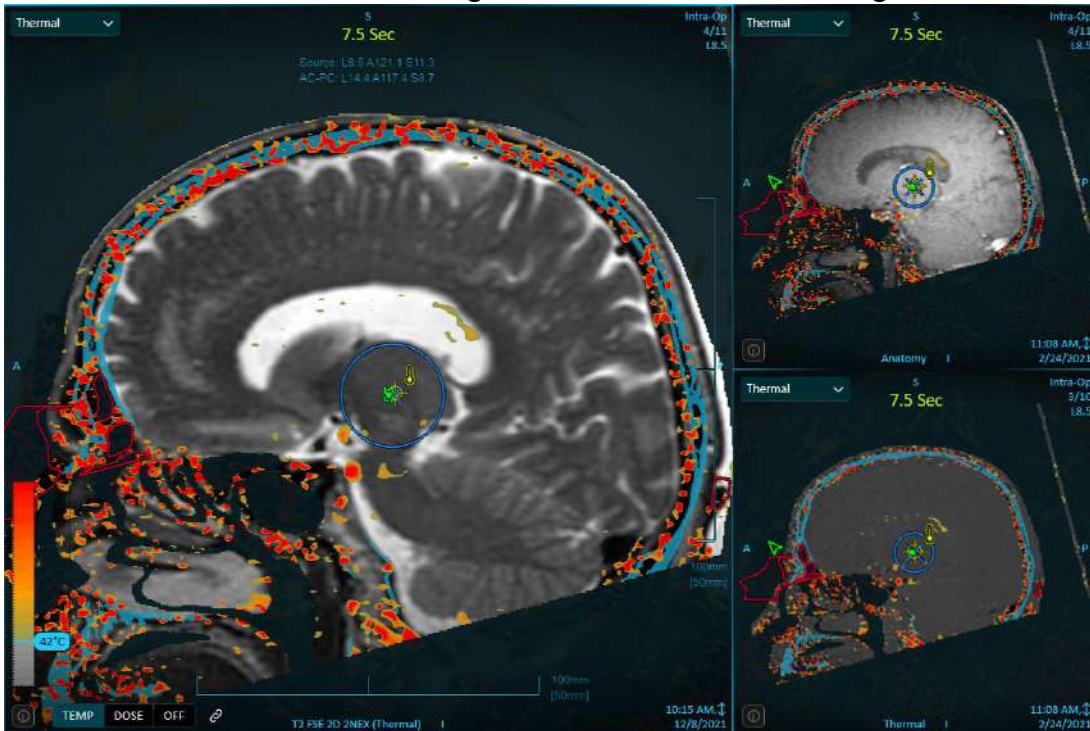

Figure 9-3: Sonication stage image window layout (Sagittal sonication)

Additionally in the REVIEW substage and in REPLAY mode, planning images (intra and pre-operative) can be reformatted into the “thermal” plane, so that it aligns to the thermal slice location and tilt.

¹ N. McDannold, P. Jason White and G. Rees Cosgrove, "Using Phase Data From MR Temperature Imaging to Visualize Anatomy During MRI-Guided Focused Ultrasound Neurosurgery," in *IEEE Transactions on Medical Imaging*, vol. 39, no. 12, pp. 3821-3830, Dec. 2020, doi: 10.1109/TMI.2020.3005631.

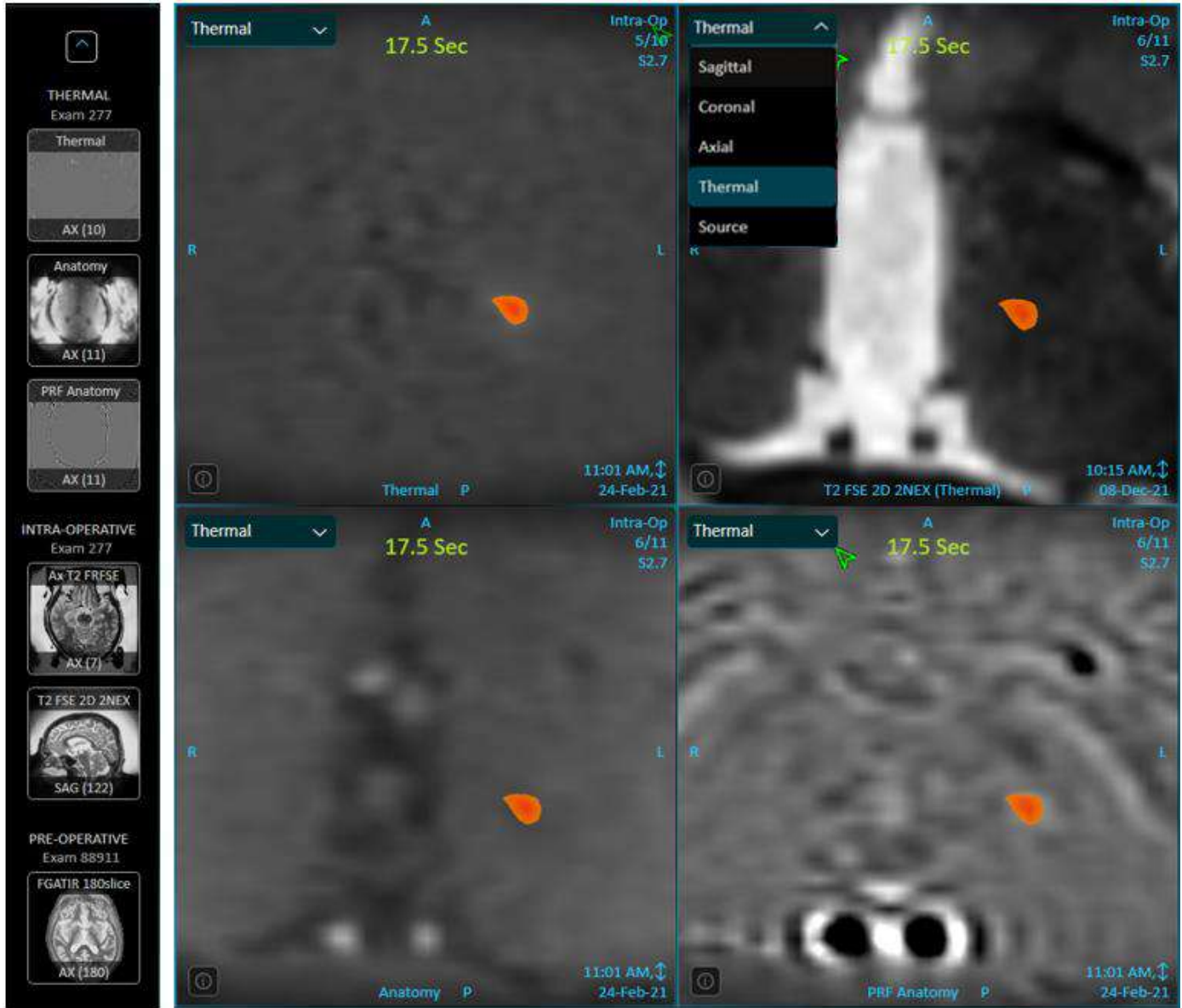

Figure 9-4: Thermal Image Types

9.1.3. Thermal Image Controls

When a THERMAL image type (as defined above, including thermally reformatted planning images) is loaded into the main image window, the thermal image controls are available.

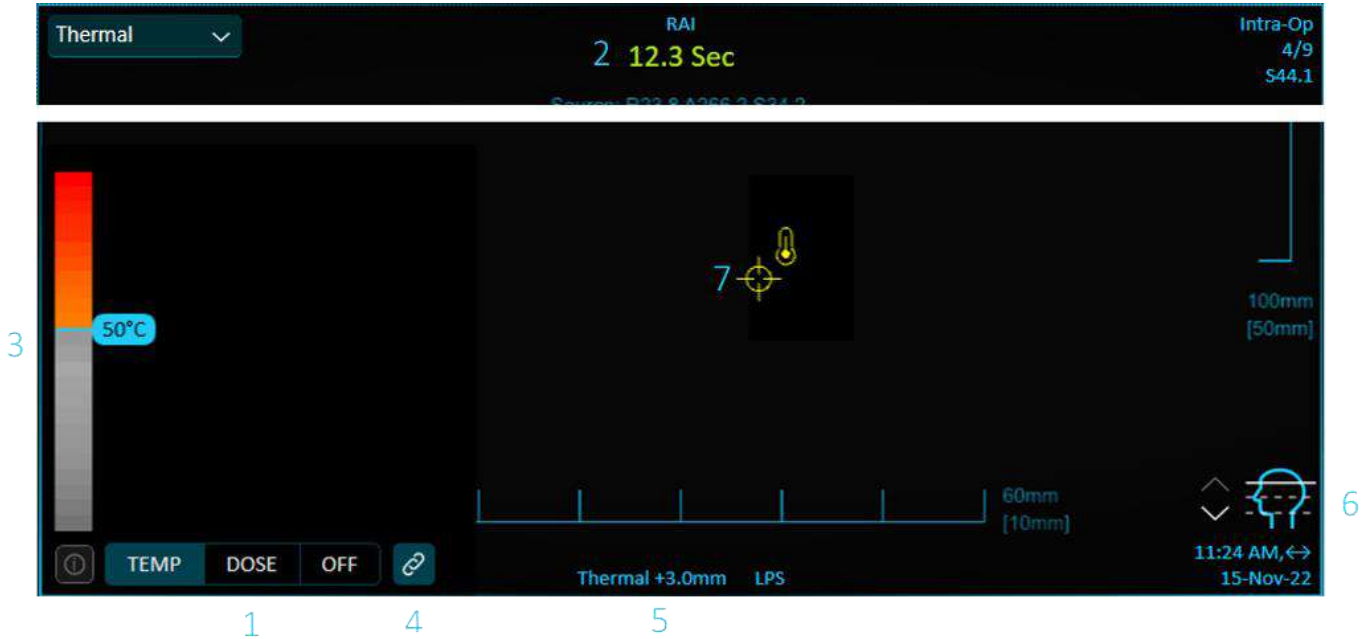
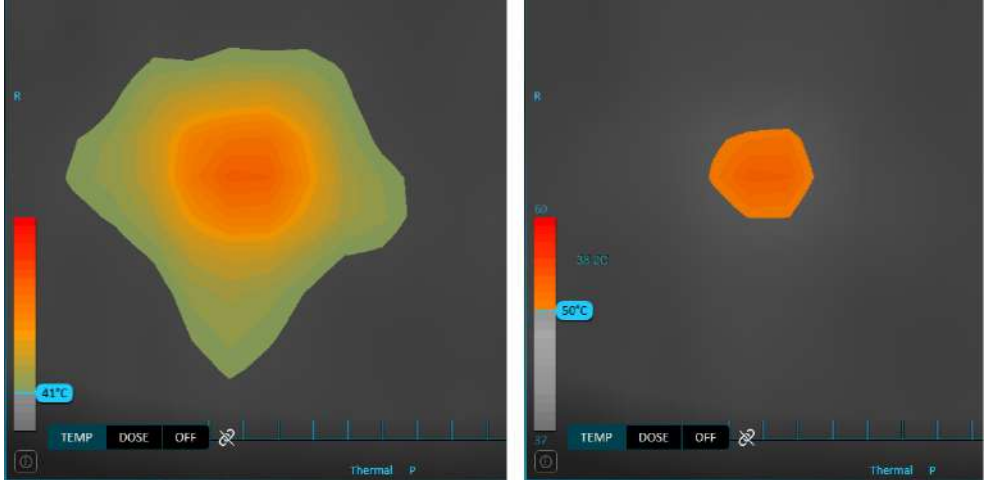
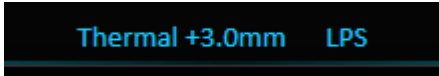



Figure 9-5: Thermal Image Controls

No.	Name	Description
1.	Thermal overlay toggle (Main window only)	<p>Toggles the thermal overlay display mode between “Temperature data (TEMP)”, “Current sonication dose (DOSE)” and OFF.</p> <p>In TEMP mode, a mask is applied on the thermal image to remove thermal noise from the image outside of the skull area.</p>

2.	Thermal phase timepoint (Main window only)	The point of the sonication's duration the currently displayed thermal phase image is centered around.
3.	Temperature overlay cutoff bar	<p>When the thermal overlay toggle is toggled to TEMP, the Temperature overlay cutoff bar appears for the user to define the minimal threshold for the thermal overlay display.</p> 
4.	Linked phase scrolling toggle	When the button is pressed, all thermal images will update to display the same thermal phase.
5.	Slice location (Multi slice only)	<p>When observing a non-central multi-slice thermometry image, the scan name annotation also displays the distance between the shown slice and the central slice:</p> 
6.	Slice selector (Multi slice only)	<p>When observing a multi-slice thermometry image, this controller enables toggling between the various slice locations. The displayed slice is indicated by the full line, whereas the other slice locations are presented as dashed lines.</p> <p>Moving between slices is done by clicking the chevrons or the icon itself.</p> 
7.	Thermal Graph Pinpoint Cursor	The thermal graph pinpoint cursor defines the point for which the Thermal graph is displayed.



NOTE:



N072

For multi-slice thermal scans, the central slice is displayed. Pressing the **Up** and **Down** arrows allows the user to navigate through the different slices of the temperature maps. An annotation on the bottom of the selected main image indicates the scan location along the perpendicular axis.

9.1.4. Therapy Stage Overlays

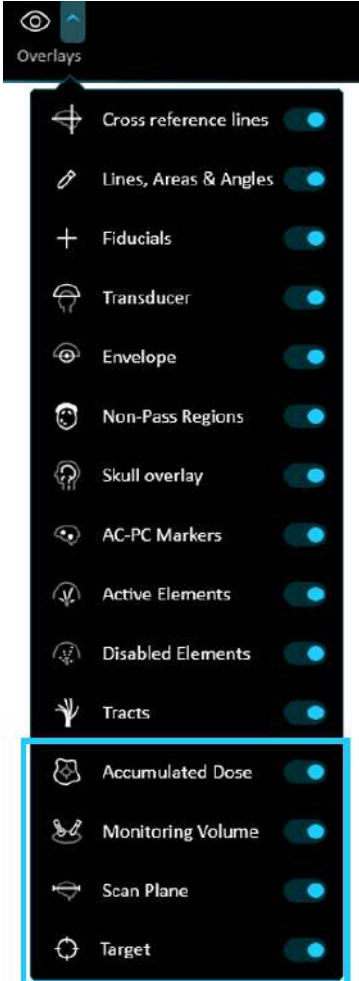
While in the Therapy Stage, three additional overlays are added to the Overlay drop down menu:

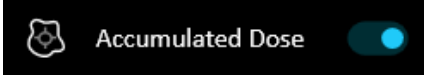
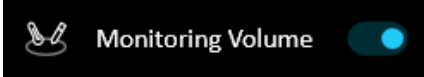
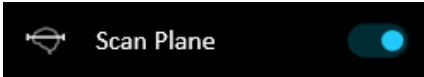

No.	Name	Description
1.	Accumulated Dose	Toggles the display of the accumulated thermal dose outlines (pink and purple) on and off. 
2.	Monitoring Volume	Toggles the display of thermal monitoring volume's outlines (Orange) on and off. 
3.	Scan Plane	When toggled ON, dark blue line intersects the images to demonstrate thermal scan plane location and tilt. 
4.	Target	Press this button to hide/display the target overlay. It automatically activates when transitioning between sonication stages. 

Note that the settings of the Therapy overlay toggles will remain unchanged if returning to the PLAN substage, but they may not be changed in the PLAN stage scenes.

9.1.5. Temperature Graph

9.1.5.1. Temperature Graph Features in the Define Substage

The temperature graph is used to set the target and limit temperatures in the Define substage:

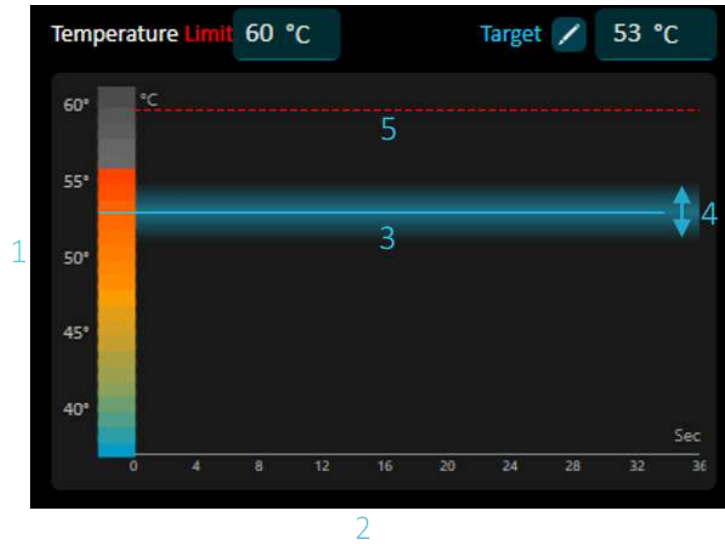

Figure 9-6: Temperature Graph

No.	Name	Description
1.	Temperature axis and bar	The colored values denote the predicted range for the manually set Power/Duration parameters (see definitions in Section 9.4, The Define Substage). Scale will adjust upwards of 60°C to fit the requested/limit temperature if needed.
2.	Duration axis	Horizontal axis represents sonication duration, including post-sonication cold phases.
3.	Target temperature line	Denotes the target/predicted peak AVG temperature for the upcoming sonication (see definitions in Section 9.4, The Define Substage).
4.	Target temperature range strip	Displays acceptable deviation range for the predicted temperature.
5.	Temperature limit line	Displays the temperature limit value for the “Thermal Loop” mechanism. (See definitions Section 9.4, The Define Substage).

9.1.5.2. Temperature Graph Features in the Sonicate and Review Substages and Replay Mode

The temperature graph enables the evaluation of heating over time across multiple points of interest both during and after the sonication.

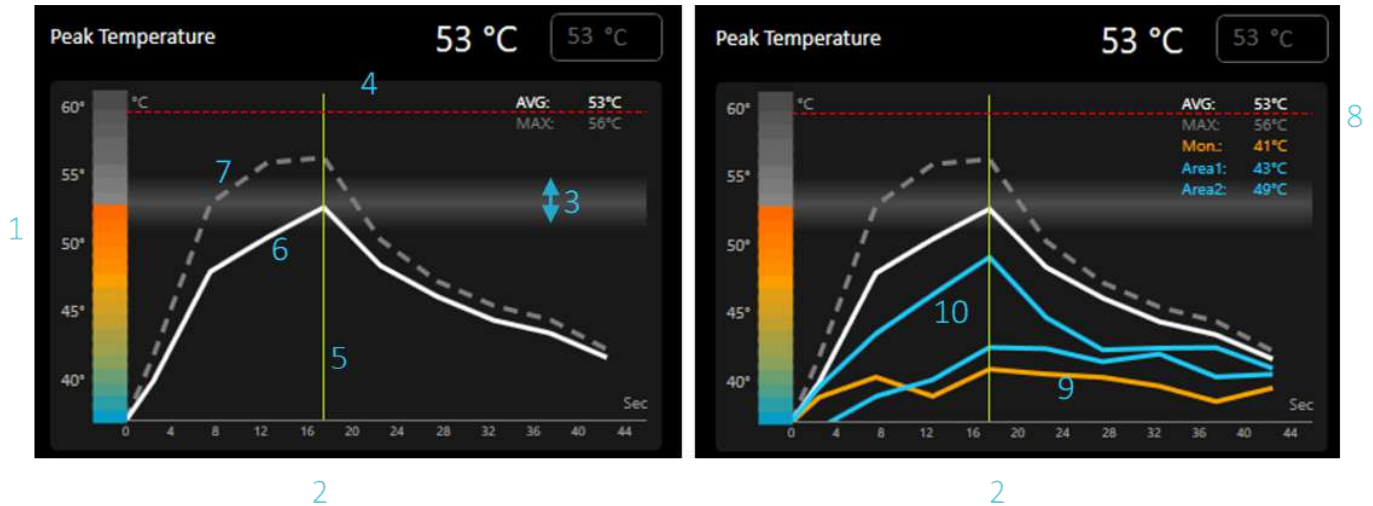

Figure 9-7: Temperature Graph Features

No.	Name	Description
1.	Temperature axis and bar	Colored up to the Peak Temperature of the displayed point. Scales upwards from 60°C to 100°C based on the displayed point’s peak MAX temperature.
2.	Duration axis	Scaled to the actual duration of the sonication and post-sonication cold phases
3.	Target temperature range strip	Displays the predicted Target temperature range for the displayed sonication
4.	Temperature limit line	Displays the temperature limit value for the “Thermal Loop” mechanism. (see definitions in Section 9.4, The Define Substage).
5.	Displayed phase line	Intersects the temperature graphs at the timepoint corresponding to the displayed timepoint on the active image. If the image in the active window is not of a “Thermal” orientation, the line will not be shown.
6.	Peak AVG temperature line	Solid white line. The average temperature of a 3x3 grid centered around the Thermal Graph Pinpoint Cursor, over time. This is considered the value to look at, as single voxel measurements are more prone to artifacts and noise.
7.	Peak MAX temperature line	Dashed grey line. The temperature at the individual voxel selected by the Thermal Graph Pinpoint Cursor over time. Useful for determining measurement quality and distinguishing between actual heating and a noisy measurement.

8.	Localized peak MAX and AVG values	The maxima of the MAX and AVG temperature lines at the current Thermal Graph Pinpoint Cursor location (not to be confused with the Global sonication Peak (AVG) temperature).
9.	“Peak AVG voxel in monitoring volume” temperature line	Solid orange line. The AVG temperature curve of the hottest voxel contained within the Temperature monitoring volume (as auto marked by a fiducial).
10.	“AVG temperature in area” line	Solid teal line. Displays the Average temperature of all voxels within a drawn area, vs time. Multiple Area graphs are supported (up to 5 at the same time).

The information on the graph corresponds to the Thermal Graph Pinpoint Cursor location on the active window. If the image on that window is no longer Thermal, the graph retains its information until the cursor is moved.

9.2. Therapy Stage Warnings and Cautions



WARNING:

W084

Before each sonication, confirm that the water system is functioning properly and that:

- There are no water leaks from the transducer by visually inspecting the transducer area.
- The blue **Circulation indication LED** on the operator's console is not flashing. A flashing light indicates an error, such as abnormal pressure levels or a suspected leak.
- Degassing level is normal and PPM value is less than 1.5.



WARNING:

W093

- Remind the patient to stop sonication when feeling pain or heat.
- If any undesired signs appear, the **Stop Sonication** button must be pressed immediately.



WARNING:

W092

In case of an unanticipated system action or patient reaction, the operator, the supporting clinical staff or the patient can immediately stop the system with the **Stop Sonication** button.



WARNING:

W085

In case of patient movement or repositioning, you must return to the **Plan Stage**, scan new planning images, and create a new plan based on these new images.



WARNING:

W088

Confirm a moderate, gradual increase in energy between sonications with respect to the current treatment stage energy in which a hot spot was observed.

**WARNING:**

W087

The measured temperature assumes a background temperature of 37°C. In the case of a different true baseline temperature, please adjust the baseline temperature.

**WARNING:**

W086

In the case of abnormal system behavior, unexpected thermal maps, temperature rise, or the inability to see or understand thermal maps, abort the sonication and treatment immediately.

- Before sonicating:
 - If there is a need to increase treatment energy, do so in gradual steps and monitor any thermal rise after each sonication.
- During the sonication:
 - Monitor the temperature maps during the sonication. If an unexpected thermal rise is found outside the target location, stop the sonication.
 - If there is a need to stop the sonication process, press the Stop Sonication button.
- After sonicating:
 - Carefully examine the thermal images and the thermal dose contours after each sonication to avoid possible damage to unintended tissues.
 - Monitor the thermal rise at the target location, and at the relevant pass zone with special attention to the interface at the skull and other sensitive regions.

9.3. Treatment Flow and Approach

9.3.1. Iterative Treatment Approach

The Exablate treatment strategy relies on methodically increasing the temperature at the target, gradually passing through specific temperature levels to ensure proper and safe targeting and treatment outcomes.

9.3.1.1. 'Align' Level – up to 46°C



WARNING:

W096

This is effectively the beginning of the treatment; select the spot parameters cautiously. Refrain from using >400W for your first sonication.



NOTE:

N078

- The default scan orientation will be axial.
- Initial parameters for first sonication, aiming to reach 44°C, are based on the default sonication duration and max 400W limitations.

Alignment sonications are used to perform Geometric Verification, confirming that the thermal spot can be identified and is located at the intended location at non-lesional temperatures (see details below).

9.3.1.2. 'Verify' Level – up to 50°C

Thermal Spot Verification is used to confirm that the tissue response and physiological feedback are as expected, prior to using a permanent lesioning temperature.



WARNING:

W097

Once suitable parameters for treatment have been determined, physiological feedback is as expected and an acceptable spot size is achieved, switch to **Target Ablation** mode.

9.3.1.3. 'Treat Low' Level – up to 55°C

Target stimulation and ablation at low temps is used to deliver therapeutic energy to tissues in order to achieve an initial permanent response to confirm location and effect are as expected.

Switching to **Target low** levels will generate an initial prediction of the spot parameters that will theoretically increase the level of the peak temperature to be within 51° to 55°C.

9.3.1.4. 'Treat High' Level – up to 63°C

Target ablation at high temps is used to deliver therapeutic energy to tissues to confirm the creation of the required lesion as expected.

Switching to **Target Ablation** treatment level will generate an initial prediction of the spot parameters that will theoretically increase the level of the peak temperature to be within 55 to 63°C

9.3.2. Geometric Verification

Geometric Verification is used to confirm that the thermal spot can be identified and is located at the intended location. To ensure proper tissue targeting and to avoid injury to non-targeted tissue, geometric verification must be performed prior to ablative sonications.

If needed, SPOT ALIGNMENT can be performed to adjust the targeting and compensate for detected offsets.

The **Adjust** function (in the REVIEW substage's TOOLS tab) corrects the transducer's electronic position according to the offset between the sonication location and the target, as defined by the user based on the thermal spot's location.

Note that spot adjustment is reset upon calibration or significant transducer movement.

9.3.2.1. Geometric Verification warnings and cautions



WARNING:

W090

Accurate transducer alignment calibration at the start of the treatment is critical.



WARNING:

W089

The geometric verification procedure must be repeated if one or more of the following incidents occur during treatment:

- Repositioning of the transducer or updating **Plan Stage** parameters
- Modifying CT/MR registration
- Patient movement is detected, and new planning images are loaded
- No **Pass Region** polygons have been modified
- Thermal hot spot is not seen on thermal imaging sequence during treatment.
- Spot placed in new target location



WARNING:

W094

Exercise extreme caution before performing an adjustment:

- If an adjustment is required, it must be performed. However, do not perform an adjustment unless you can clearly see the entire hot spot and are certain that the adjustment is necessary.
- If the adjustment is over 2 mm, before performing it, perform another sonication with a different orientation (that shows the same direction), to confirm the necessity of the adjustment.
- Failure to do so may increase the risk of unintentionally treating non-targeted tissue.

**WARNING:**

W095

Do not continue with the treatment if a hot-spot is not adequately visible and confirmed to be well-aligned with the planned target, in all three dimensions.

**NOTE:**

N077

- Targeting accuracy is correlated with thermal imaging quality. This allows the system to detect any incongruency between the thermal spot center and the actual lesion location with an accuracy of 1mm.
- Target accuracy is affected by the CT of the skull and the targeted tissue.

9.3.2.2. Geometric Verification Procedure

To perform Geometric Verification, ensure that the spot is centered around the target (within 1.0 mm) along all three axes (R-L, S-I, A-P). This typically requires 2-3 sonications.

In case an offset is found, perform a SPOT ALIGNMENT CORRECTION and repeat the sonication to verify alignment. Verification should be performed at low ("alignment") temperatures of up to 46°C.

9.3.2.3. Spot Alignment Correction Instructions

1. Every sonication has a pre-set frequency direction, along one of the plane's main axes. If a hot spot can be adequately identified, verify that it is within 1.0 mm of the planned location along the phase direction. If it is, continue with verifying its location on other orientations.
2. If the hot-spot is over the 1.0 mm margin, select the CORRECT SPOT ALIGNMENT button, then press on the hot-spot center in the Selected Image window to adjust it to the correct position.
3. Upon the pop-up message for spot location adjustment, the default setting varies based on the thermometry type used. For MEMP-based thermometry, the "ignore frequency direction" checkbox will be unchecked by default, allowing the spot correction in both orientations. Conversely, for TMAP, it'll be checked by default, limiting the correction to the phase direction only. As needed, this checkbox can be altered when prompted by the pop-up message, although it's not recommended for TMAP-based thermometry.

9.3.3. General Sonication Flow

**WARNING:**

W091

Always adhere to the sonication safety instruction as defined herein.

Failure to do so may result in patient injury

1. Verify that the patient is comfortable.

2. Examine the desired sonication spot:

- When highlighted in green, the spot is valid and may be treated.
- When highlighted in yellow, the spot is either above the energy density on one of the **NPR's**, or it crosses the threshold of energy density on the skull. Cautiously try to optimize the location and/or the orientation. Check the parameters and assess if the clinical situation allows this sonication.



NOTE:

N074

When the untreated spot is not green, the reason is displayed in the information box at the top-right corner of the screen when you press on the spot.

3. Based on the examination of the actual dose, previous sonication performance and patient feedback, determine the sonication plan:

- Adjust sonication parameters: **Energy, Duration, Frequency, Time Extension.**
- Confirm that the estimated external and internal temperatures are adequate.
- Change thermal scan parameters (MR protocol, scan orientation, frequency direction).

4. Press the **Sonicate** button to apply the ultrasound energy.



CAUTION:

C029

If the sonication parameters prescribed by the user have exceeded the system's performance or safety limits, updated parameters will be presented before sonication starts.

5. Right before energy delivery, **Tracking** and **Movement Detection** scans are performed, and the system automatically detects if patient or transducer movement has occurred.

6. During sonications, the following factors should be monitored:

- Patient discomfort or abnormal reactions
- Energy transmission, as displayed by the energy bar
- Spectrum signal during the transmission of acoustic energy
- The evolving temperature rises during sonication

7. After sonicating, the Therapy DEFINE substage screen will appear with the actual thermal dose contour. Review the results:

- Drag the cursor around the image and evaluate the temperature graphs. Change the accepted peak temperature if needed.
- Analyze the thermal results near the skull and the thermal dose in the sonication area.
- Toggle Background Temperature Correction OFF/ON to evaluate the image quality.
- If the resulting temperature map is deemed unreliable, toggle the reject sonication button to reject the measured thermal dose and accepted peak temperature.

8. Press the ACCEPT & CONTINUE button (or REJECT & CONTINUE, if rejected) to return to the DEFINE substage and plan the next sonication OR conclude the treatment.



NOTE:

N075

After continuing to the next sonication, you will not be able to edit the **Accumulated Measured Dose** of previous sonications or the **Accepted Peak Temperature** for the **Treatment Levels (Temperature Estimator)**.

9. Repeat the procedure until all planned sonications have been performed, or alternatively repeat the selected spot until you have reached the desired clinical outcome (for a single target). Changes to the treatment plan are possible at any stage during treatment.
10. Observe previous sonication information and images in the REPORT or REPLAY mode as needed.

9.3.4. Ending a Treatment Session

After the treatment session, the patient may be released from the treatment table. Verify that:

1. The cradle is pulled out of the MR bore.
2. The water is drained from the transducer and Transducer is moved superiorly.
3. The patient is released from the frame holder and membrane.
4. The Head frame is removed.
5. The patient is examined in the recovery room.



CAUTION:

C030

Exit (and shutdown) the workstation at the end of the last session of the day.



WARNING:

W098

Adhere to the handling, and cleaning instructions for coils and membranes as detailed in the 'Patient Membrane and Coil Handling Procedure' (Section **Patient Membrane and Coil Handling Procedure**). Failing to comply with the above may result in reduced imaging quality, water leakage, cross-contamination, burns and electrocution risk.



CAUTION:

C047

To comply with Cleaning and Disinfection requirements, residual water may not be left in the Front End. Make sure a FE drain is performed at the end of each treatment (following transducer drain, before discarding of the water).

9.4. The Define Substage



Figure 9-8: Define Substage Screen

9.4.1. Define Substage Overview

The DEFINE substage provides the means to prepare and plan a sonication prior to the actual delivery of energy.

It encompasses the following elements and controls:

- Define substage toolbox, which includes:
 - Predicted/limit temperature graph
 - Sonication parameters
 - Scan orientation parameters
 - Target coordinates
 - Collapsible preference and tool tabs
 - Tools Tab
 - Sonication preferences tab (including advanced sonication controls)
 - Scan preferences tab (including advanced scan controls)
- SONICATE button
- The navigation bar enables the user to review the treatment summary REPORT or review previous sonications by entering enter REPLAY.

9.4.2. Define Substage Toolbox Controls

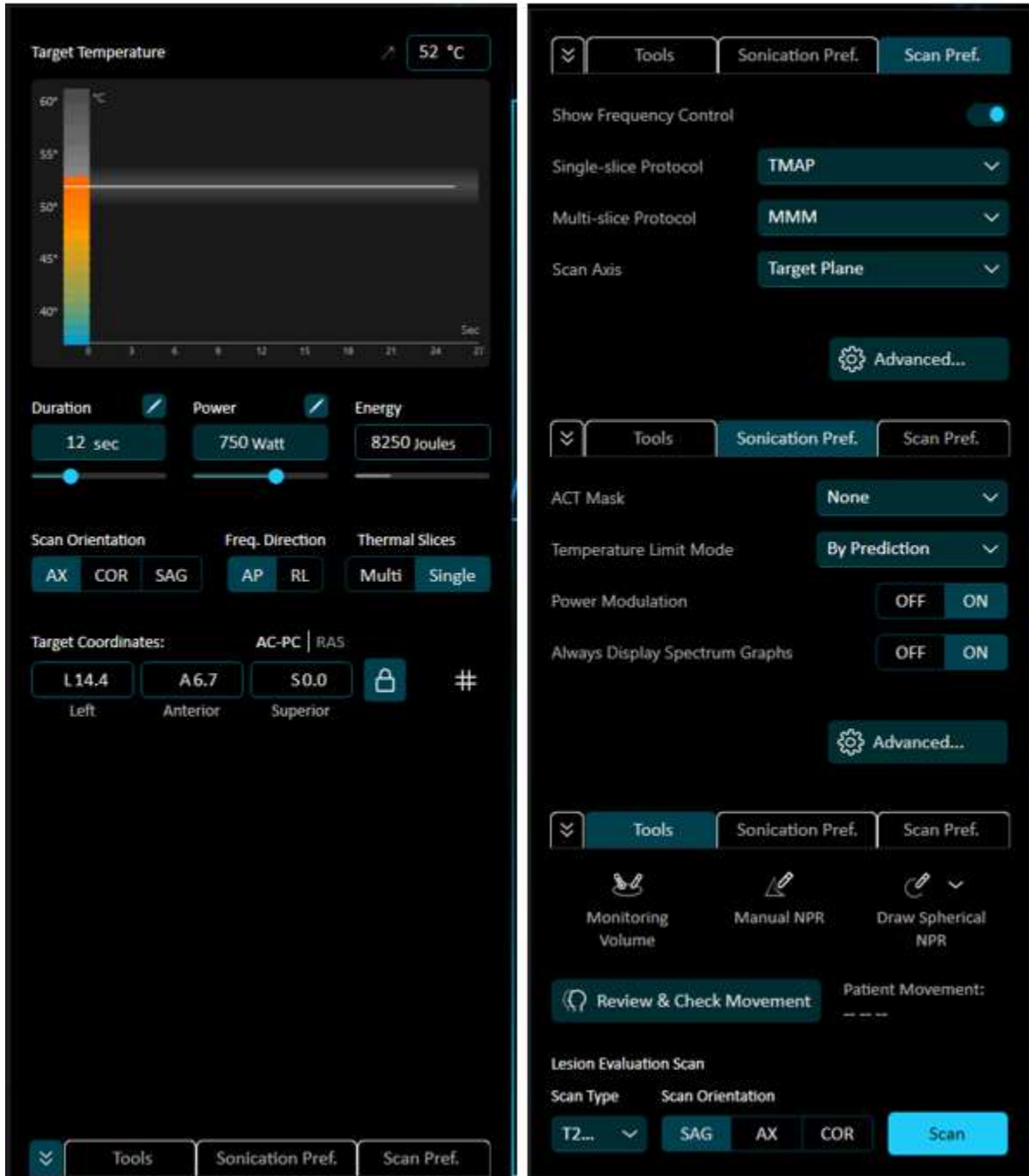

Figure 9-9: Define Substage Toolbox Controls

9.4.2.1. Sonication Parameter Control

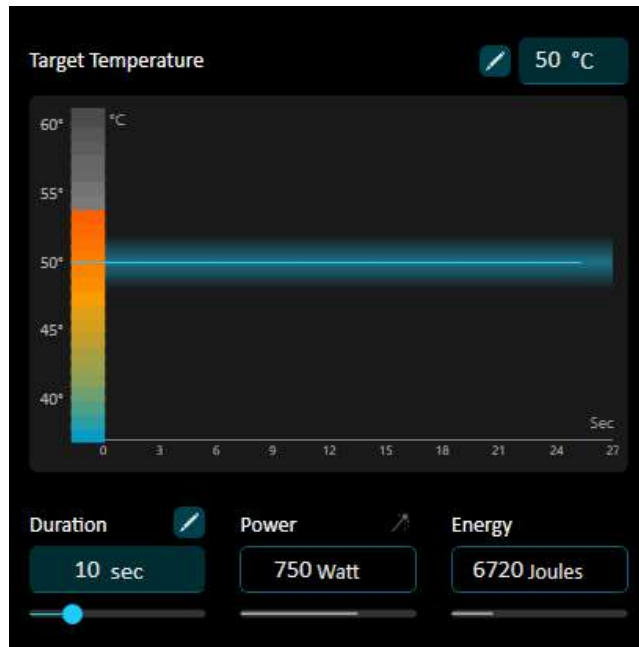

Figure 9-10: Sonication Parameter Control

The sonication parameter controls customize a sonication’s Target temperature, power and duration.

Exablate Prime’s prediction algorithm relies on two manually defined parameters to suggest the most suitable value for a third parameter. To toggle a “manually set” field as “automatically calculated,” press the “pen” icon. This field then becomes represented by a “magic wand” icon, its respective data field loses its colored background, and it becomes non-editable.

For example, in the image above, the system provides a suggested power of 750W to reach a specific temperature (50°C) in a specified duration (10 seconds).

The horizontal line on the graph marks the target/predicted temperature, including a “fuzzy margin” of $\pm 2^{\circ}\text{C}$. When the target temperature is “manually set” the line turns teal and can be dragged manually. The temperature can also be adjusted directly by clicking/typing in the parameter box.

Power and duration may be adjusted by clicking/typing in their respective parameter boxes, or by dragging the blue dot on the bar below them. Maximum power and Duration range values may be extended in the “Advanced Sonication Preferences” menu.

When selecting the sonication duration, a green dot will appear in the corner of the duration field, indicating the closest match to a thermal image’s phase.

The Energy field is non-editable. The projected energy calculation accounts for the gradual power ramp at the start of a sonication, hence why it is not a direct multiplication of the Power and Duration.

The temperature range bar is grey for temperatures for which no calculated suggested value exists. Extending the other manual parameters may enable higher temperatures to be reached.

A warning sign appears in the top right corner of the temperature graph if the predictor fails to suggest parameters, or if the prediction suffers from low certainty.



CAUTION:

C028

Verify the desired sonication parameters before performing a sonication. Unintended sonication parameters may result in ablation of unintended tissue. Check the temperature estimation and confirm spot location before each sonication.

If the sonication parameters prescribed by the user have exceeded the system's performance or safety limits, updated parameters will be presented before sonication starts.

9.4.2.2. Temperature Limit Mode

In addition to the Target temperature, an additional “Temperature Limit” value may also be defined.

During sonications, the temperature in the target area is being monitored using real-time thermal imaging. If temperatures exceed the maximum defined temperature value, the system will automatically cease energy transmission, while the MR scan will continue as prescribed. If this occurs prior to the penultimate thermal phase, it is also accompanied by an informative pop-up message. This is known as the “Thermal Loop” mechanism.

Three Temperature Limit modes are supported:

- By Prediction – The Temperature Limit is set to one degree (°C) above the Target Temperature.
- Manual - The Temperature Limit, represented by a dotted red line, can be set by typing a value into the Temperature limit parameter box, or by dragging the dotted red line.
- By Level - the temperature limit can be set via a drop down to four predefined values:
 - Align – 46°: The hot spot center location is being evaluated and adjusted.
 - Verify – 51°C: Tissue response and transient physiological feedbacks are expected.
 - Treat Low – 55°C: Therapeutic energy delivered to tissues that require low temperatures.
 - Treat High– 62°C: Aims to reach an adequate temperature level within the target that will ensure permanent, controlled lesioning of the anatomical structure.

The limit is represented by a dotted red line on the target temperature graph.

The Temperature limit mode can set from the “Profiles” tab of the “Settings” screen or changed from the “sonication preferences” menu in the Therapy Define substage (during a treatment).

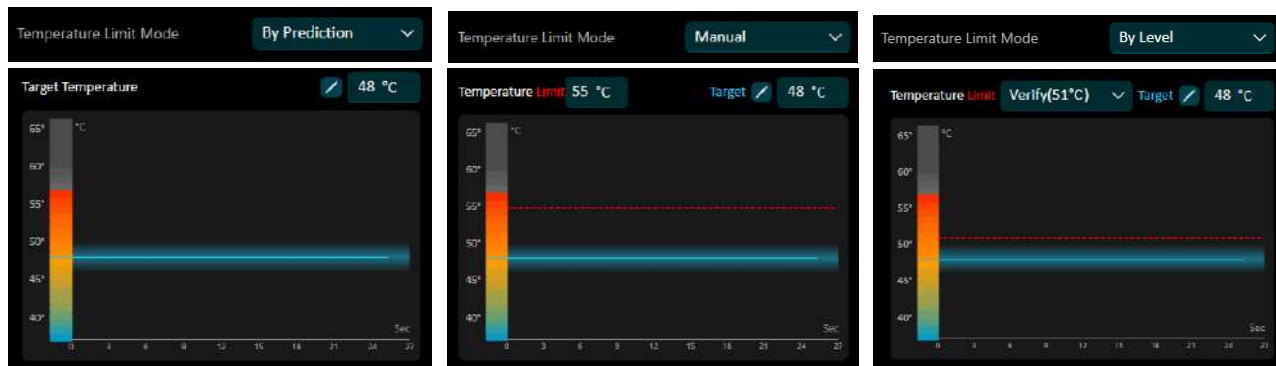



WARNING:

W101

Always select your treatment level or temperature according to the desired sonication outcome.

Note that the sonication halt based on a temperature limit will always lag approximately half a phase behind energy emission, thus the final temperature may be several degrees above the threshold.



WARNING:

W081

When aiming to increase target temperatures, use a moderate, gradual increase in energy with respect to the previously observed peak temperature at the target.



WARNING:

W082

The temperature limit mechanism is meant to keep temperatures within the intended limits as per treatment stage. Exercise caution when increasing the temperature limit value.

9.4.2.3. Parameter Prediction Modes and Constraints

By default, the parameter predictor model is set to “Default” mode which provides the aforementioned prediction. However, it can also be set to “simplified” mode which utilizes the linear predictor used in previous Exablate neuro versions, and does not support predictions of Power or Duration, only Temperature. The parameter prediction model can be changed from the “Profiles” tab of the “Settings” screen, or from the “advanced sonication preferences” menu in the Therapy Define substage (during a treatment).

Note that the prediction accuracy for the first three sonications is slightly lower (as the prediction adapt based on performed sonications). Sonications which are rejected in the Therapy Review substage are not taken into account for the predictions.

9.4.2.4. Thermal Scan parameters

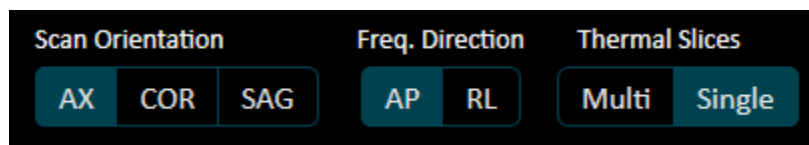

These controls allow the user to prescribe the desired orientation and type of the upcoming thermal scan.

The orientation can be set to Axial, Sagittal, or Coronal, and the scan’s frequency direction can also be toggled. The user may also toggle between single slice and multi-slice thermometry (if available).

Note some thermal sequences are limited in terms of available orientations and frequency directions.

For advanced thermal scan settings see the Section **9.4.3.4, Scan Preferences Tab**.



WARNING:

W113

Switching between scan orientations and frequency directions is important in order to obtain an optimal estimation of heating position, shape, and size.

9.4.2.5. Target coordinates

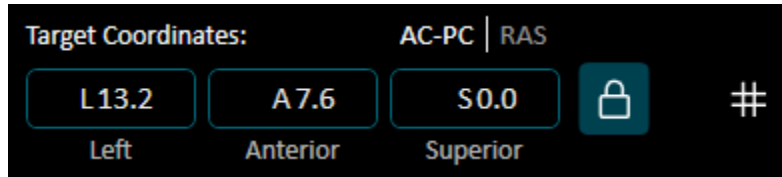

The target coordinates may be unlocked, which enables changing the target location by typing or clicking the coordinate boxes, or by dragging the target.

The change to the target location when compared to the previously sonicated target is displayed below the target coordinates, based on the selected coordinate system (AC-PC/RAS).

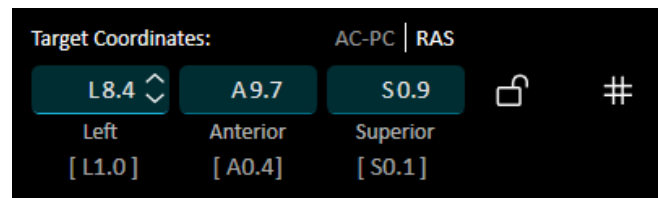
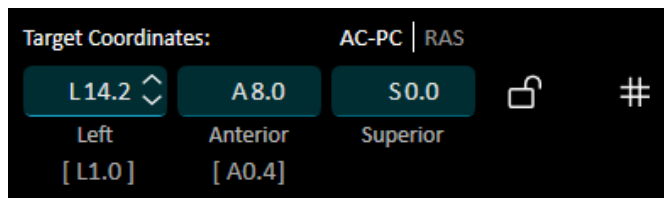

NOTE:

Pay attention to signs while inserting the spot coordinates (i.e., L/R, A/P and S/I).

N067



CAUTION:

Make sure you confirm the spot's location with the MR images after manually inserting a set of coordinates.

C027

The targeting grid overlay may be toggled ON (if the displayed images are reformatted by the AC-PC plane).

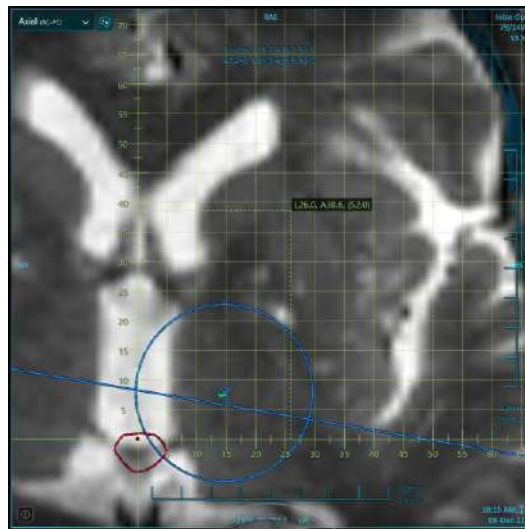

9.4.3. Define Substage Toolbox Tabs

9.4.3.1. Tools Tab

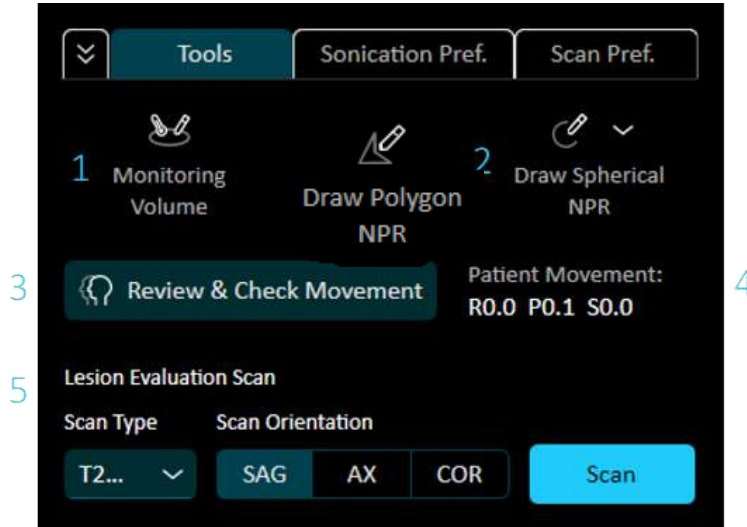

Figure 9-11: Define Substage Tools Tab

No.	Name	Description
1.	Monitoring Volume	<p>Use this feature to add a 3D region in which the temperature rise will be monitored during the sonication. Draw a closed contour region on one or more of the MR images. The hottest AVG temperature curve in the volume will be plotted (vs time) on the temperature graph. That voxel will also be auto marked with a fiducial.</p> <p>Note that all drawn shapes will be considered as a single volume.</p>
2.	Polygon NPR / Spherical NPR	Use these buttons to Add NPR markings, just like those in the NPR substage.
3.	Review & Check movement	Enter Movement Evaluation & Review screen (see Section 8.9.1, Movement Evaluation Toolbox)
4.	Patient Movement Vector	Displays the last calculated patient movement detection vector
5.	Lesion evaluation scan controls	Define orientation and protocol and initiate a Quick Lesion evaluation scan centered around the target and spanning 8-12 slices. This scan is considered as belonging to the previous sonication.

9.4.3.2. Sonication Preferences Tab

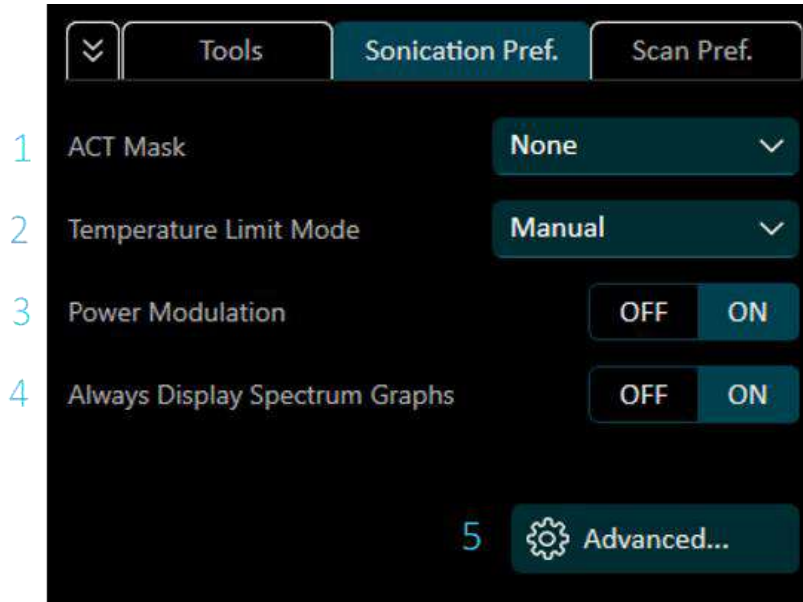

Figure 9-12: Sonication Preferences Tab

No.	Name	Description
1.	ACT Mask	The ACT Mask file determines the amplitudes and the phases of the transducer elements. ACT Masks are typically used to address spot distortion. See section 117 4.2.1.1 Transducer Map
2.	Temperature Limit Mode	Toggle between the three Temperature Limit Modes (see subsection 9.4.2.2, Temperature Limit Mode in section 9.4, The Define Substage) The default Temperature Limit Mode can be set in the Profiles screen.
3.	Power modulation	Toggle Power modulation ON/OFF. When ON, the system will reduce power automatically until the acoustic signal falls below the threshold. The system then will try to increase power again while keeping the acoustic signal below the threshold. When OFF the system will automatically stop energy transmission if the acoustic signal crosses the predefined thresholds. Note that the threshold for stopping a sonication on account of cavitation is the same regardless of this toggle's state. The default Power Modulation setting is defined by the selected Profile.
4.	Always display spectrum graphs	When ON, the spectrum graph is always displayed during sonications. The Default setting is defined by the selected Profile.

5.	Advanced...	Open the Advanced Sonication Preferences Menu (see below)
----	-------------	---

9.4.3.3. Advanced Sonication Preferences Menu

All parameters remain set until adjusted again or starting a new treatment from the main menu.

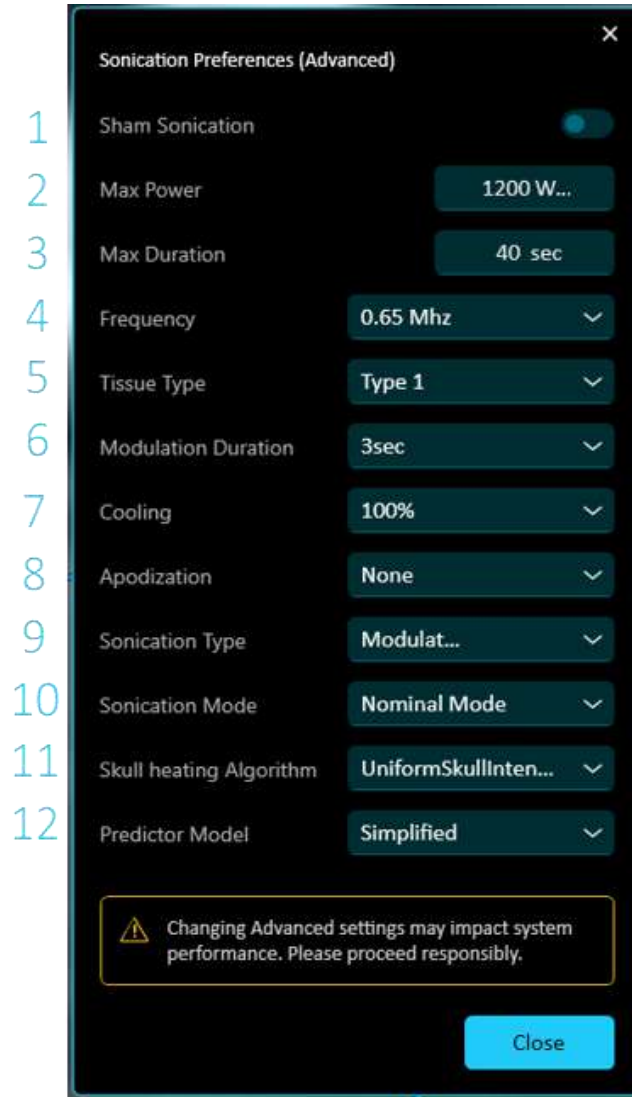

Figure 9-13: Advanced Sonication Preference Menu



WARNING:

W099D

Improper use of **Advanced Option Mode** may degrade the quality of treatment and may even result in personal injury. Do not alter these settings without consulting your InSightec representative.



WARNING:

W100

Before pressing 'Sonicate' for a Sham sonication, ensure that the planned sonication power displayed on screen does not exceeds 1 Watt.



NOTE:

N083

The cavitation halt safety thresholds for both tissue type settings are identical.

No.	Name	Description
1.	Sham Sonication	Zero energy sonication, if required (e.g. for Sham treatment in blinded double arm study). When Sham is set to ON, power and duration are forcibly set to 0.
2.	Max Power	Set the maximal power limit for the sonication power parameter box and slider. See the Sonication Monitoring and Control (Advanced) section to set as default.
3.	Max Duration	Set the maximal duration limit for the sonication duration parameter box and slider. See Sonication Monitoring and Control (Advanced) section to set as default.
4.	Frequency	It is possible to slightly change the Exablate transducer's transmission frequency. Since every Exablate installation is already calibrated per site, this is not recommended.
5.	Tissue type	<p>There are two options for tissue type:</p> <ul style="list-style-type: none"> • Mode 0 – For use when treating complex tissue (boundary areas, near scars or for unknown or previously untreated tissue types, for example under clinical trials). In this mode, the system has lower thresholds for spectrum-based power modulation. • Mode 1 – when treating approved indications, away from any anatomical, the user may switch to Level 1. Level 1 Tissue Type sonications allow for more variability in the acoustic signal prior to power modulation, and can therefore be used, for example, to overcome stutters in the power increase ramp. <p>See Sonication Monitoring and Control (Advanced) section to set as default.</p>
6.	Modulation Duration	When “Power modulation” is set to ON, this setting defines the maximal duration a sonication can extend beyond the original prescribed Duration in order to reach the prescribed energy. See Sonication Monitoring and Control (Advanced) section to set as default.
7.	Cooling	Allows adjustment of the scaling of cooling times between sonications. The cooling time between sonications is automatically calculated according to the actual energy applied and sonication parameters, and should not be decreased.
8.	Apodization	This determines the effective transmitting area of the transducer. Select an Apodization Percentage to determine the effective transmitting area of the transducer out of the total active elements.

9.	Sonication Type	For use by Research or Advanced users, after consulting your application specialist. Prior to Research/Advanced training use only 'Modulated Sonication'.
10.	Sonication Mode	For use by Research or Advanced users, after consulting your application specialist. Prior to Research/Advanced training use only 'Nominal Mode'
11.	Skull heating algorithm	For use by Research or Advanced users, after consulting your application specialist. Prior to Research/Advanced training use only 'UniformSkullIntensity'
12.	Predictor Model	Toggle between "Default" and "Legacy" temperature prediction models. See "Parameter prediction modes and constraints" for details. See Sonication Monitoring and Control (Advanced) section to see as default.

9.4.3.4. Scan Preferences Tab

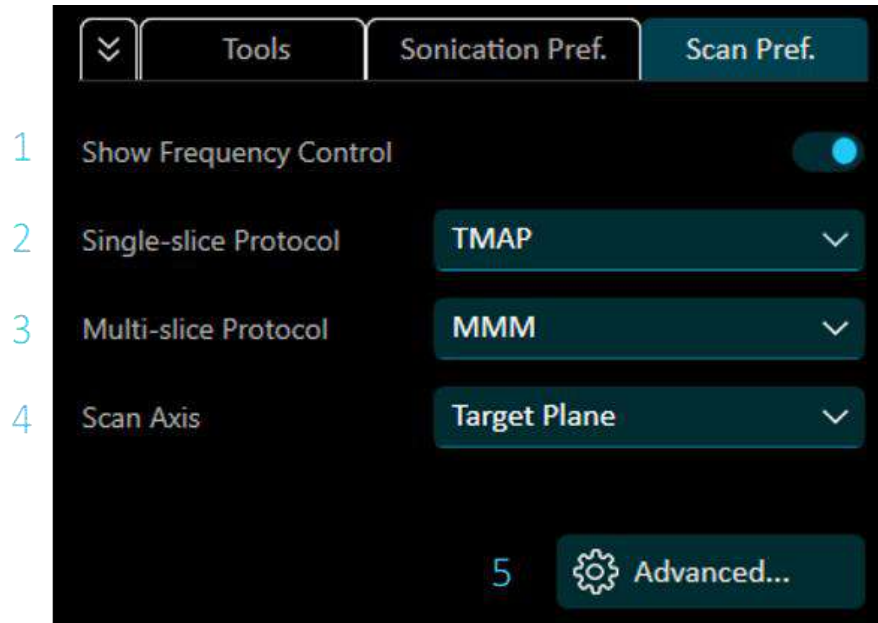

Figure 9-14: Scan Preference Tab

No.	Name	Description
1.	Show frequency control	Toggle the display of the Thermal scan frequency direction toggle. Note this cannot be turned off for single echo thermal protocols.
2.	Single-slice Protocol	Select the thermal protocol associated with the “Single” selection in the Thermal Scan Parameters
3.	Multi-slice Protocol	Select the thermal protocol associated with the “Multi” selection in the Thermal Scan Parameters (if applicable)
4.	Scan Axis	Thermal images can either be acquired by a coordinate system aligned to the MRI Plane (Scanner RAS) or by the target plane (AC-PC Plane effectively). The default Scan Axis preference can be set in the Profiles screen.
5.	Advanced...	Open the Advanced Thermal Scan Preferences Menu (see below)



NOTE:

N068

For each selected sonication, the thermal scan lines are automatically displayed on the screen, to demonstrate thermal scan plane location and tilt.

9.4.3.5. Advanced Thermal Scan Preferences Menu

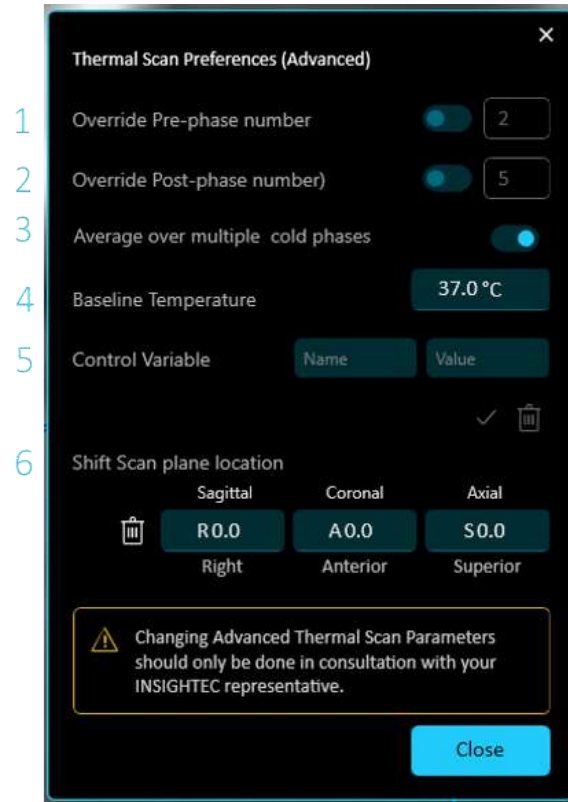

Figure 9-15: Advanced Thermal Scan Preferences Menu

No.	Name	Description
1.	Override Pre-Phase Number	Change the number of cold phases acquired prior to energy delivery
2.	Override Post-Phase Number	Change the number of cold phases acquired following energy delivery
3.	Average over multiple cold phases	Toggling Average over multiple cold phases ON will cause the system to take an average baseline reading over all pre-sonication phases.
4.	Baseline Temperature	The default is normal body baseline temperature. Change this value to the temperature of the organ treated.
5.	Control Variable (GE MRI Only)	Enter Control Variable Name and value and press “V” to apply it for the thermal scan. The tooltip hover above the “trash can” icon presents all activated CVS. Pressing it resets the CV list.
6.	Shift scan plane Location	Shift the different Thermal scan orientation planes



CAUTION:

Changing Advanced Thermal Scan Parameters should only be done in consultation with your InSightec representative.

C046

9.4.4. Sonicate Button



The sonicate button initiates the sonication sequence.

Pressing the SONICATE button means that target location, scan and sonication parameters are set and can no longer be altered for the active sonication.

9.4.4.1. Sonicate Button availability

For the SONICATE button to be available the following conditions must be met:

- The target coordinates are LOCKED
- The spot is valid (see Section 8.8, **Targeting Substage** for definitions)
- MRI and Device are in READY state
- The previous sonication's cooling period is complete

9.4.4.2. Sonication validation

Once the sonicate button is pressed, various calculations and checks are performed, which may result in the following warnings and pop-ups [with these options]:

- The predicted temperature rise is too steep [Abort sonication/Continue]
- Measured PPM value in water is above threshold [Abort sonication/Continue]
- Measured water temperature value is above threshold [Abort sonication/Continue]
- Calculated Power is lower than requested power [Abort sonication/Continue]
- Local energy density is above the recommended value [Abort sonication/Continue]

Additionally, if the SONICATE button is pressed immediately after a change in sonication parameters, or if there is a delay in parameter calculation, the following dialog is displayed in order to make sure these are the requested parameters and intended target temperature.



NOTE:

N069D

- A minimum of 700 elements ON is advised for an effective treatment.
- Available Skull area should exceed 200 cm²



NOTE:

N079

- If the spot appears red, it is invalid and cannot be sonicated.
- If the spot appears yellow, try to optimize the location and/or the orientation.

9.5. The Sonicate substage

9.5.1. Sonicate Substage Overview

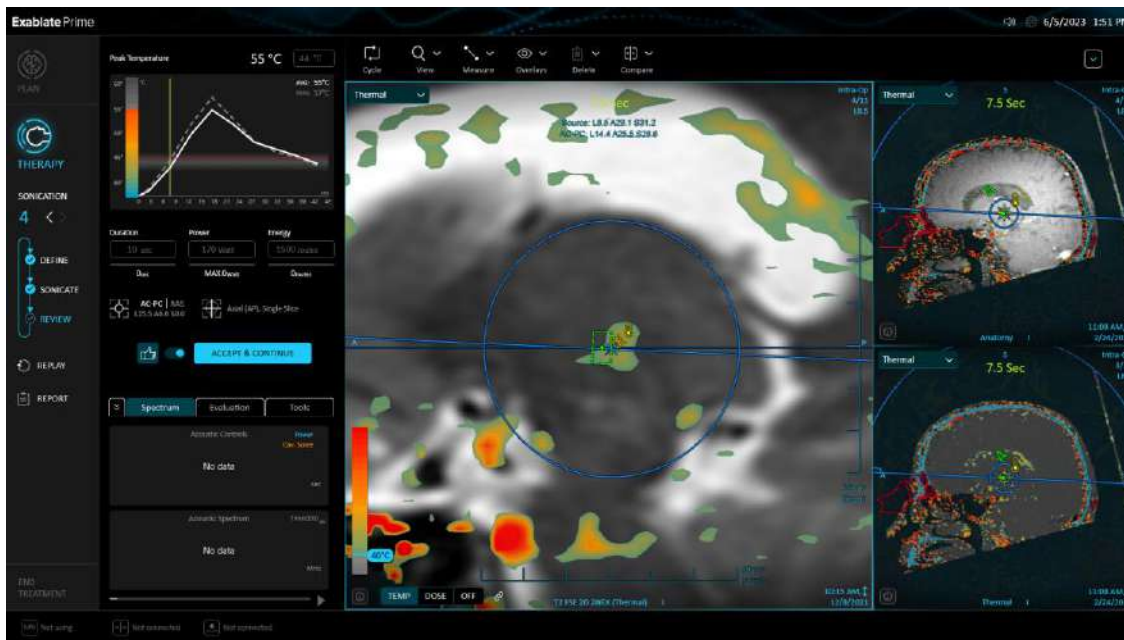
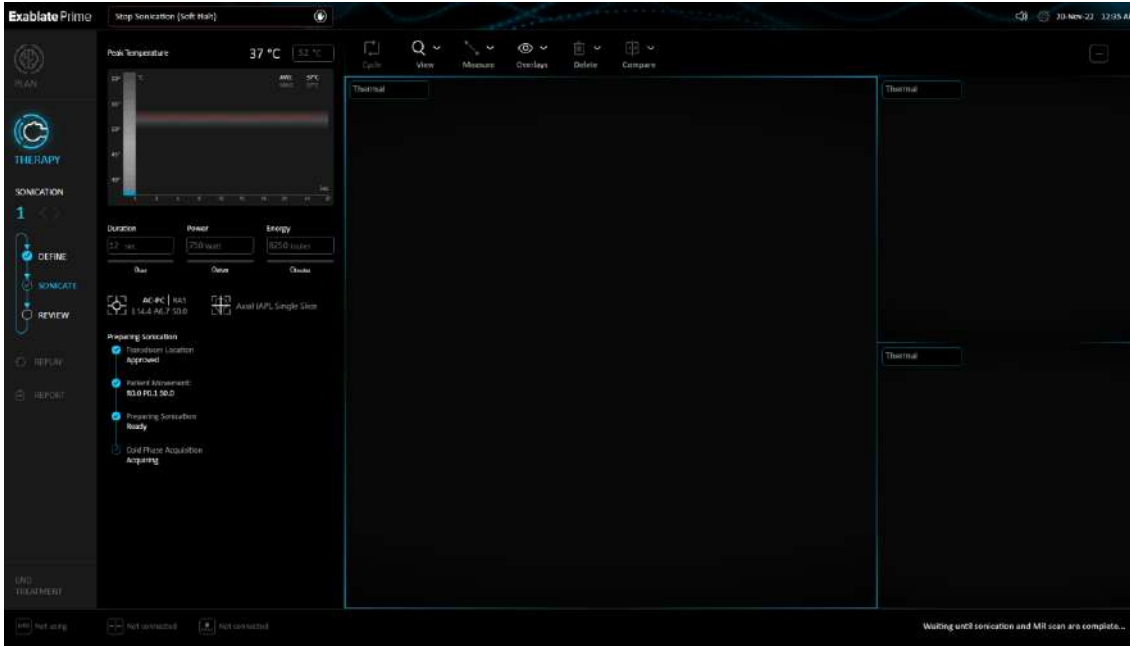

9.5.1.1. Sonicate substage phases

The SONICATE substage is initiated by pressing the SONICATE button and includes the following phases:

- Pre-sonication
 - Transducer movement check
 - Patient movement check
 - Sonication Preparation
 - Pre sonication cold phase acquisition
- Active Sonication: Energy is delivered to the target location. Thermal images are automatically retrieved and loaded into image windows at set intervals.
- Post sonication cold phase acquisition: Energy is no longer being delivered. Thermal images are automatically retrieved and loaded into image windows at set intervals. The temperature and acoustic spectrum are monitored in order to ensure cooldown and assess the thermal measurements quality.

9.5.1.2. Sonicate Toolbox component overview

- Dynamic Temperature graph
- Sonication parameter and progress information
- Target coordinate information
- Thermal scan information
- Pre-sonication progress indicators (During pre-sonication only)
- Collapsible dynamic acoustic spectrum graphs (from start of energy delivery)

All of the above are non-interactive elements, meaning they serve to present information, but cannot affect the sonication.

Additionally, a **“Stop Sonication” (soft halt)** is located above the substage toolbox during the sonication. It differs from the Console’s stop sonication button by the fact that it does NOT stop the MR scan. This is the same behavior as a thermal loop or cavitation detection halt.



9.5.1.3. UI limitations

- The image thumbnail bar is collapsed and locked
- Navigation bar
 - No navigation to PLAN stage or REPLAY mode,
 - cannot END TREATMENT
 - cannot open REPORT
- The SETTINGS screen is disabled
- Image Viewer Toolbar
 - The CYCLE button is disabled
 - DELETE, MEASURE and COMPARE are unavailable
 - The TRANSDUCER MAP cannot be opened

9.5.2. Sonicate Substage Toolbox Controls



Figure 9-16: Sonicate Substage Toolbox

No.	Name	Description
1.	Stop Sonication (Soft Halt)	<ul style="list-style-type: none"> Pressing this button during the pre-sonication flow shall abort the sonication fully and return the user to the DEFINE substage – it will not count as a sonication. Pressing this button once pre-sonication cold phase acquisition has commenced (or later) shall stop power delivery and transition the sonication directly to post-sonication cold phases acquisition, followed by the REVIEW substage.
2.	Peak Temperature	 <p>The value in gray is the predicted maximal temperature as set in the DEFINE substage. The value in white is the current calculated peak (MAX AVG) temperature for this sonication.</p>
3.	Thermal Graph	Displays the measured temperature development at the temperature pinpoint cursor's location (AVG and MAX) as well as peak temperature in any Temperature Monitoring Volumes. For further details see below.
4.	Sonication progress bars	 <p>The values in gray are the sonication parameters as set in the DEFINE substage. The values in white are the current Power and accumulated Duration and Energy in the sonication, and they are dynamically updated throughout the sonication. The white bars represent the current/defined ratio.</p>
5.	Target and Thermal Scan information	 <p>These fields display the target coordinates (in RAS or AC-PC coordinates) and the thermal scan's orientation, frequency direction, and type (single/multi slice).</p>

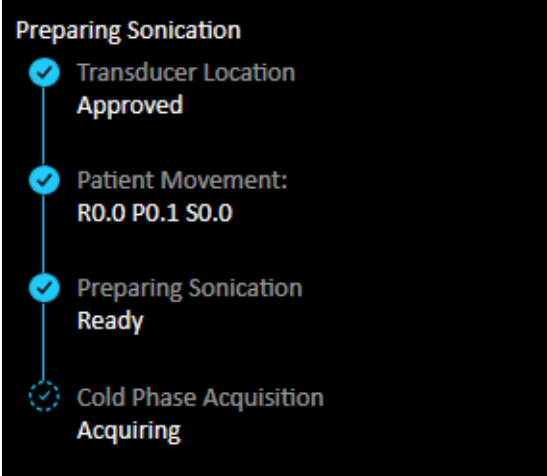
<p>6. Pre- Sonication Progress (During Pre-Sonation only)</p>		 <p>The pre-sonication progress follow up bar displays the current phase of the pre-sonication flow, as well as each steps result.</p> <ul style="list-style-type: none"> • In case of scan failures the user is alerted and the sonication is aborted • If Transducer movement is detected the user is alerted and the sonication is aborted • If suspected patient movement is detected, the user is alerted and invited to review movement detection images. The sonication is aborted. <p>If a sonication is aborted during the Pre-sonication phase it does not count as a sonication.</p>
<p>7. Spectrum Graphs (During Sonication only)</p>		<p>Displays spectral and modulation activity during a sonication (once the pre-sonication phase is complete). Is collapsible and it's default state is defined by the selected profile of in the Sonication Pref. tab in the DEFINE substage.</p> <p>For further details see below.</p>

9.5.3. Temperature Graph

The temperature graph is updated constantly throughout the sonication. For specific temperature graph definitions see relevant chapter in Define stage overview section.

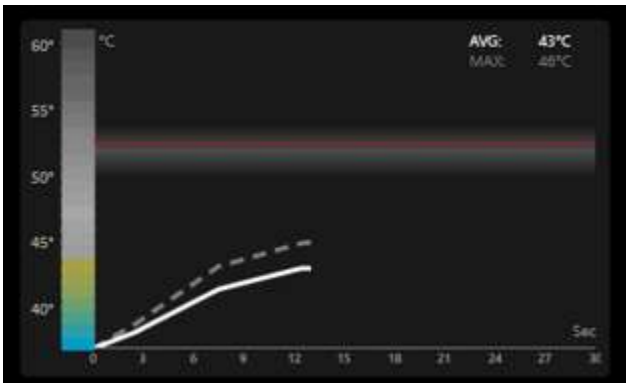

NOTE: N073
 The graph may be used to display the temperature history of any location by moving the cross-shaped cursor with the mouse.

9.5.4. Spectrum graphs

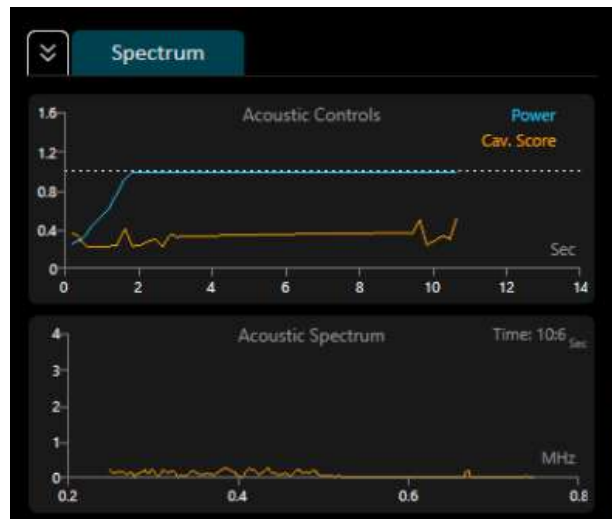

Figure 9-17: Spectrum Graphs

The **Acoustic Spectrum** and the **Acoustic controls** graphs assist in detecting the creation of micro-bubbles associated with cavitation effects and observing the systems’ response to such information.

Acoustic Spectrum Data – presents the spectrum of frequencies that are transmitted back to the transducer. Elevated signal around 0.3-0.4 kHz may indicate cavitation activity. Note the treatment frequency is filtered out of this graph.

Acoustic Controls (Levels) – present two graphs:

- **Spectral Energy Score** – displays the intensity of the spectrum frequencies at each time point (orange/yellow line).
- **Power Percentage** – displays the normalized actual transmitted power for each time point throughout the sonication (green line).

Acoustic Spectrum with high values in the range of half the transmitting frequency; indicates the possibility of cavitation effects and will result in a **Spectral Energy Score** above the dashed horizontal line. If this occurs during sonication, the system will react depending on the current Acoustic mode:

- If **POWER MODULATION** is set to **OFF**, it will cease energy transmission, while the MR scan will continue as prescribed.
- If **POWER MODULATION** is set to **ON**, power will be reduced automatically until the **Spectral Energy Score** will be below the threshold. The system then will try to increase the power again while keeping the spectral energy below the threshold.

The initial state of the graph (open/collapsed) is defined by the selected Profile and can be adjusted from the **SCAN PREF.** tab in the **DEFINE** substage.

9.5.5. Sonication Halts

There are two types of sonication halts.

- A **full halt** is when both the active sonication (i.e. power delivery) and the accompanying MRI scan are halted. Possible reasons for full halt:
 - Stop sonication button press (User, Physician, Front End)
 - MRI Failure
- A **soft halt** is when power delivery is halted but rather than stop the accompanying MRI scan, additional cold phases are acquired. Possible reasons for a soft halt:
 - Cavitation halt
 - User has pressed the “Stop sonication (Soft Halt)” button
 - HW malfunctions

The benefit of the soft halt is that it enables the operator to observe the full thermal curve, without the risk of “losing” the peak measurement.

Following both types of halts (or a successful sonication completion), the Therapy flow progresses to the REVIEW substage.

9.6. The Review substage

9.6.1. Review Substage Overview

The REVIEW substage provides the means to evaluate the results of the current and previous sonications. It is very similar to the SONICATE stage screen, with the following changes/additions:

- The image thumbnail bar is available
- Addition of “PRF Anatomy” image type
- “Evaluation” and “Tools” tabs are made available (see below)
- Movement Evaluation mode is available (view only, no option to perform a scan)
- Cooling countdown is displayed

As in the DEFINE substage, the navigation bar enables the user to review the treatment summary REPORT or review previous sonications by entering enter REPLAY.

9.6.2. Review Substage Toolbox Controls

The review substage toolbox is nearly identical to the SONICATE substage’s toolbox. With the following notable additions:

- A “Stop sonication (Soft Halt)” button is no longer displayed, as the sonication is complete
- The Accept/Reject toggle and appropriate Continue button are added to the toolbox.
- Two additional tabs join the toolbox: “Evaluation” and “Tools”
- The measured parameter bars and values display the final sonication parameters (delivered) vs. the grey, prescribed (or requested) values. Do note that the Power displayed below the requested power is the peak measured (or MAX) power.



Figure 9-18: Review Substage Toolbox

9.6.3. Image windows and loading

At the entrance to the REVIEW substage, the images windows appear as they were at the end of a sonication, centered on the hottest plane and phase detected during the sonication.

All registered images can be used to evaluate the sonication results in the various orientations, and the PRF anatomy images are added to the image thumbnail bar.

The thermal image controls are available, enabling the user to observe heating and predicted (current and accumulated) doses.



CAUTION:

C049

The hottest phase at the center of the heated should automatically be displayed upon entrance to the REVIEW substage. Ensure that the temperature graph cursor is centered at the proper location and the image window is displaying the peak temperature phase.

9.6.4. Review Substage Toolbox Controls

9.6.4.1. Spectrum Tab

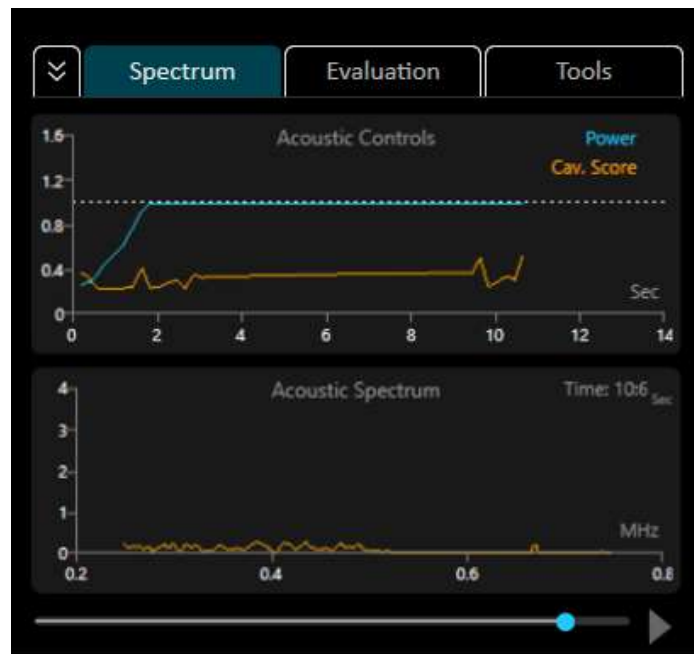

Figure 9-19: Review Substage Spectrum Tab

The spectrum tab is similar to its functionality in the Sonication substage, but it has an additional control at the bottom to scroll to specific timepoints during the sonication. Pressing “Play” will replay the entire graph repeatedly.

9.6.4.2. Evaluation Tab

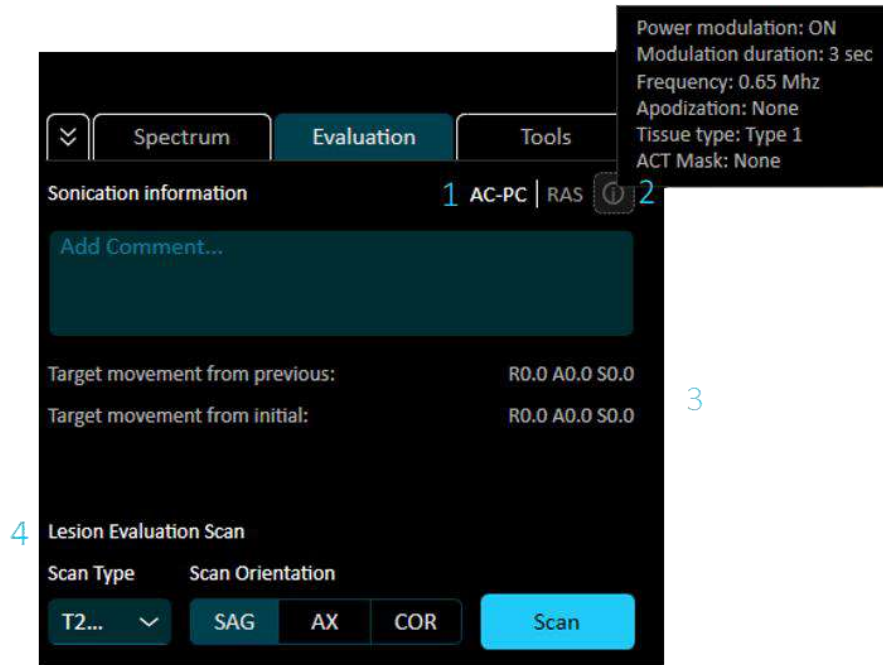

Figure 9-20: Review Substage Evaluation Tab

The evaluation tab includes additional information regarding the current sonication, and the ability to add a comment that can later be observed in REPLAY mode or the REPORT .

No.	Name	Description
1.	AC-PC/RAS toggle	Toggles the coordinate system on which the target movement vector is based
2.	Info hover icon	Displays additional information upon hover
3.	Target movement vectors	Displays the difference (movement) from the previous and initial target coordinates to the currently sonicated location.
4.	Lesion evaluation scan	Prescribe a lesion evaluation scan. Identical to the controls found in the DEFINE substage.

9.6.4.3. Tools Tab

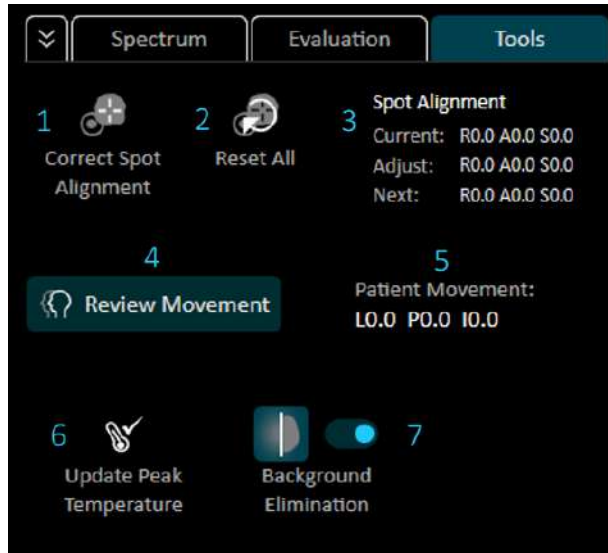

Figure 9-21: Review Substage Tools Tab

No.	Name	Description
1.	Correct Spot Alignment	Used in order to fine tune focusing. If a thermal spot is not centered on the target (>1.0mm), press the “Correct Spot Alignment” button and place the cursor at the center of the heated area. The system will attempt to correct its plan in order to account for this shift in ensuing sonications. Note the ability to ignore the correction along the frequency direction (recommended for TMAP based thermometry as it is prone to frequency shifts).
2.	Reset All	Cancel all spot adjustments performed since the start of the treatment.
3.	Alignment coordinates	Current: Adjustment during sonication Adjust: Proposed adjustment Next: Accumulated adjustment for the next sonication.
4.	Review movement	Opens the Movement Review mode screen. It is akin to the Movement evaluation screen, but there is no option to detect movement with a new scan.
5.	Patient movement vector	The last movement calculated prior to the sonication.
6.	Update Peak Temperature	Sets the peak sonication temperature to the Peak AVG temperature at the cursor’s current location.
7.	Background Elimination	The Background Elimination feature aims to correct artifacts in the background temperature resulting from various imaging artifacts,

		<p>Toggling the feature ON applies background temperature correction, according to a Background Mask which covers as large an area as possible on the temperature map of brain tissue, while avoiding skull area and air cavities displayed (mask is transparent).</p> <p>The Peak Temperature, temperature maps and graphs are updated.</p> <p>The Default Background Elimination is set to ON by default, but if toggled otherwise, the change is carried over to the next sonication.</p>
--	--	--

9.6.5. The cooling countdown display



Following a sonication, the Exablate system calculates the required time to cool down the patient’s skull.

This remaining cooling duration is displayed on screen in the REVIEW and DEFINE substages.

The next sonication may not be performed until this duration has passed (the Sonicate button is unavailable).

Note that active cooling does not prohibit the user from proceeding to the DEFINE substage, returning to the PLAN stage screens or ending the treatment.

9.6.6. Accepting or rejecting a sonication



After carefully reviewing the sonication outcomes, determining the peak temperature, and adding comments if so desired, it is time to proceed to the next sonication or end the treatment.

As long as the thermal information seems reliable, press the toggle button on and ACCEPT AND CONTINUE.

By pressing this button you accept the following **Thermal Outcomes** from this sonication:

- Measured **Thermal Dose** accumulation.
- Accepted **Peak Temperature**.

If the thermal data or dose projection suffer from artifacts and are deemed unreliable, toggle the reject sonication button and press REJECT & CONTINUE, (if rejected), this means that the sonication results and dose will not be used for accumulated dose or parameter prediction calculations.

This page is intentionally left blank for double-sided printing.

10.SETTINGS

Settings can be accessed from the **Navigation Bar** on the lefthand side of the **Entrance Screen**. The settings dialog is a dialog that enables the user to define and save some of the customizable treatment parameters and functionalities. Each user can define these parameters according to their preferences and save them to be used in subsequent treatments.

These settings provide the user with the ability to perform actions that may be used during treatment but are not necessarily part of the standard treatment flow. Some of these actions include customizing MR operations, water system operation, connection to the site network, Trackers use, and changing the Calibration mode.

10.1. Overview



WARNING:

W099D

Improper use of **Advanced Settings** may degrade the quality of treatment and may even result in personal injury. Do not alter these settings without consulting your InSightec representative.

There are three different Settings tabs: System, Profile and Entrance Screen List. Refer to the corresponding section for more information.



NOTE:

N040

The system's preset treatment profiles cannot be deleted from the list, and if edited they must be saved with different names.

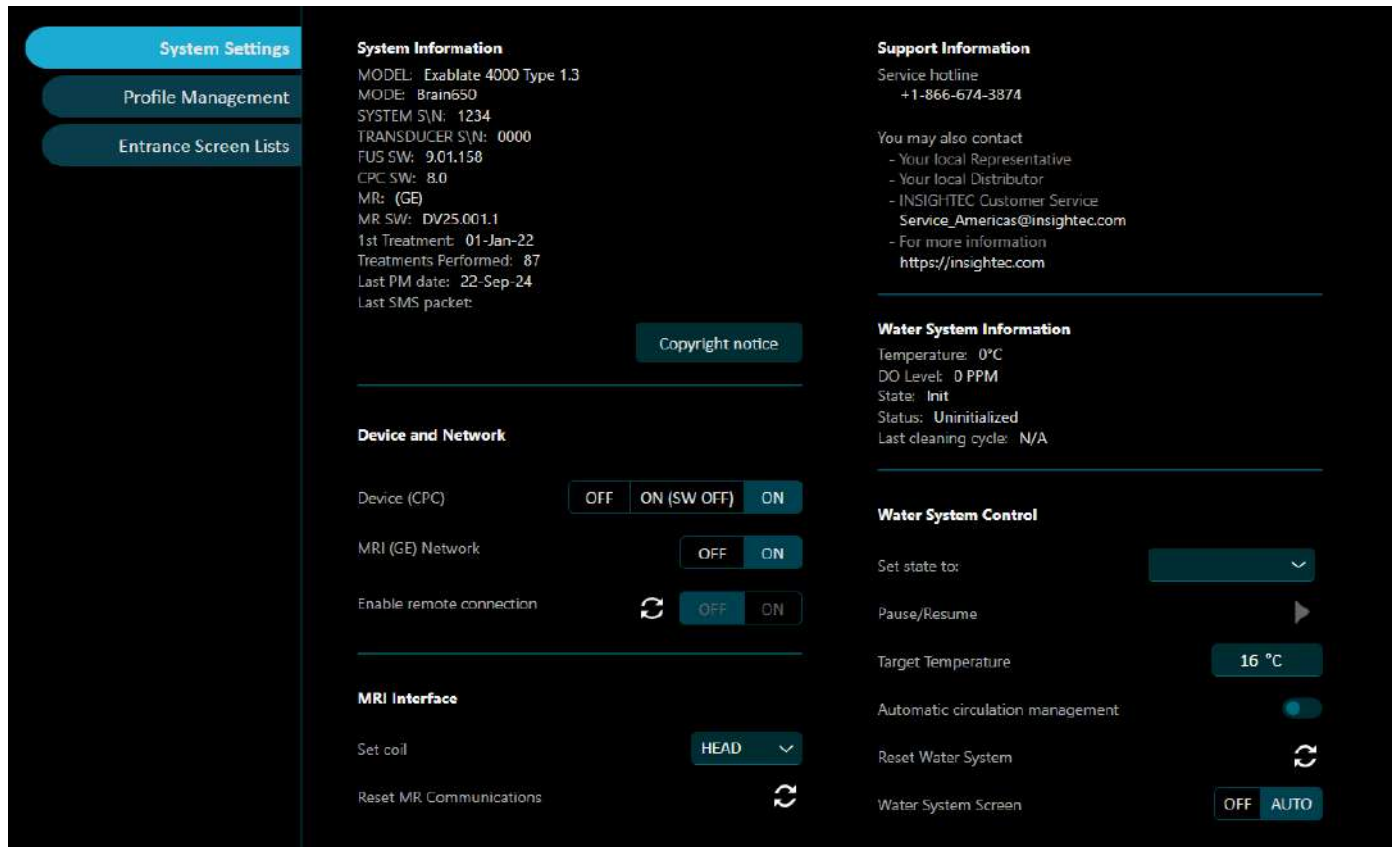

Figure 10-1: Settings Screen

10.2. System

The System Tab aggregates information about the system including general information, Device and Network, MRI Interface, Support Information, Water System Information and Water System Control. Refer to the relevant section for more details.

10.2.1. System Information

System information will display system characteristics including:

- Model
- Mode
- System Serial Number
- Transducer Serial Number
- FUS Software Version
- CPC Software Version
- MR Type (Manufacturer, 1.5T or 3T)
- MR Software version
- First treatment date with the system

- Total number of treatments performed
- Date of last Preventative Maintenance performed
- Last SMS Packet

Copyright Notice: Press this button to review the list of open-source software that components of the product may incorporate or be distributed with.

Copyright notice

10.2.1.1. Copyright Notice

Certain parts of this system may incorporate – or be distributed with – selected open-source software. Pressing the **Copyright Info** button will open a text file listing such software.



NOTE:

N104

Information regarding the system can be found in System Settings from the treatment mode as well on the bottom of the screen.

10.2.2. Device and Network

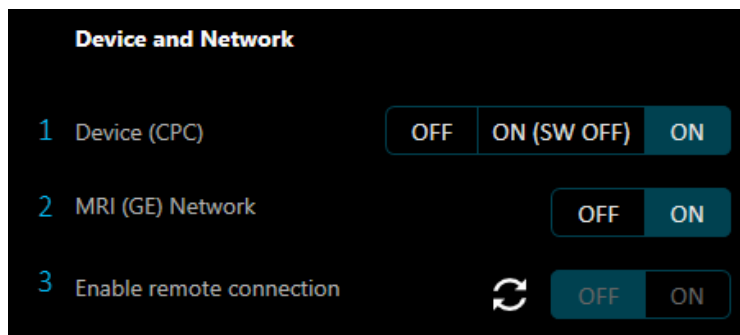



Figure 10-2: Device and Network Section

No.	Name	Description
1.	Device (CPC)	Toggle OFF to shut down the device. Once Shutdown completes (see Device Status bar). Toggle ON to power on the device. ON (SW OFF) is a state in which the device PC is on, but its software is OFF. This enables access to system logs and files without powering up elements in the MR room.
2.	MRI (GE) Network	Note this control is only available systems with GE MRI

		<p>Toggle ON to connect the MR to the hospital network.</p> <p>Toggle OFF to disconnect the MR from the hospital network.</p> <p>The MR system should be disconnected from the hospital network during a treatment. In case of an urgent need to transfer data, use this option to connect/disconnect the MR to the site network.</p> <div style="display: flex; align-items: center;">  <div> <p>CAUTION:</p> <p>Do not treat the patient while the MR is connected to the hospital network.</p> </div> <div style="margin-left: auto; text-align: right;"> <p>C031</p> </div> </div>
3.	Enable remote connection	Toggle the ON button to enable remote connection. Toggle OFF to block disable remote service and support connection capabilities.

10.2.3. MRI Interface

Reset MR Communications by pressing the reset (two arrow) button . Upon being pressed, the system will restore the connection between the Exablate system and the MRI For supporting systems – set the active coil type.

10.2.4. Support Information

In case there is a need for external support, refer to Section **10.2.4, Support Information** as described in the picture below.

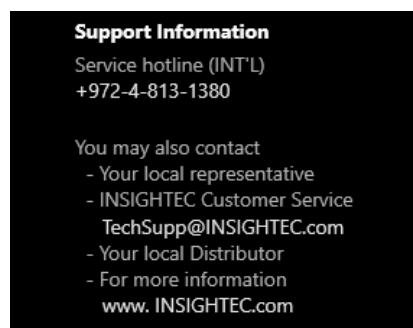

Figure 10-3: Support Information

10.2.5. Water System Information

The Water System Information Section shows in real time the water system characteristics as shown in the picture below.

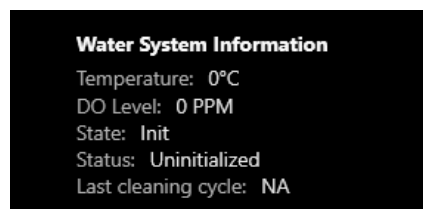

Figure 10-4: Water System Information

10.2.6. Water System Control

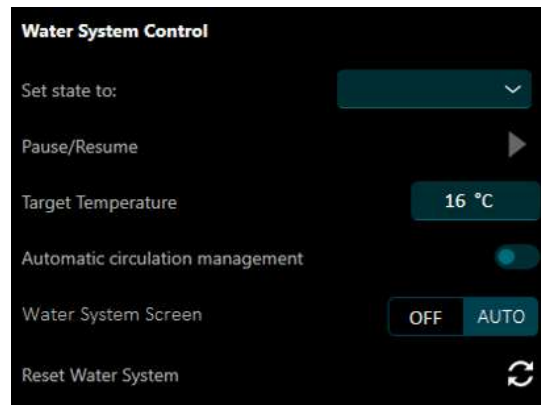

Figure 10-5: Water System Control Section

No.	Name	Description
1.	Set state of water system	Toggle down in this field to set system to either degassing (before treatment or DQA) or circulation (therapy) mode.
2.	Pause/Resume	When play button is displayed, press to begin circulation (in either degassing or circulation mode.) Press again when pause symbol is displayed to pause circulation.
3.	Target Temperature	Change the value within the target temperature field to desired therapy stage water temperature.
4.	Automatic Circulation Management	This feature is used to automatically control water circulation during a treatment to prevent artifact in MR images from erroneous circulation during scanning. Toggle the slider on to set the system to automatically pause circulation during scanning or sonication, and to resume circulation after scanning or sonication is complete.
5.	Water System Screen	This button enables to turn ON/OFF the Front End screen.
6.	Reset Water System	Press the two arrow cycle button to reset the water system when it is in an error state (due to pressure, secondary flow issues, or a vacuum error) according to the water system status indicator. Water system will return to “circulation paused” state. Press the two arrow cycle button again to restart circulation.

10.3. Profile Management

The Profile Management Tab enables users to create/modify a treatment profile. A treatment profile allows the user to configure and save multiple treatment preferences such as planning scan type, thermometry scan type, and lesion evaluation (intra-operative) scan type to be used during a treatment. Refer to the corresponding section for more details.

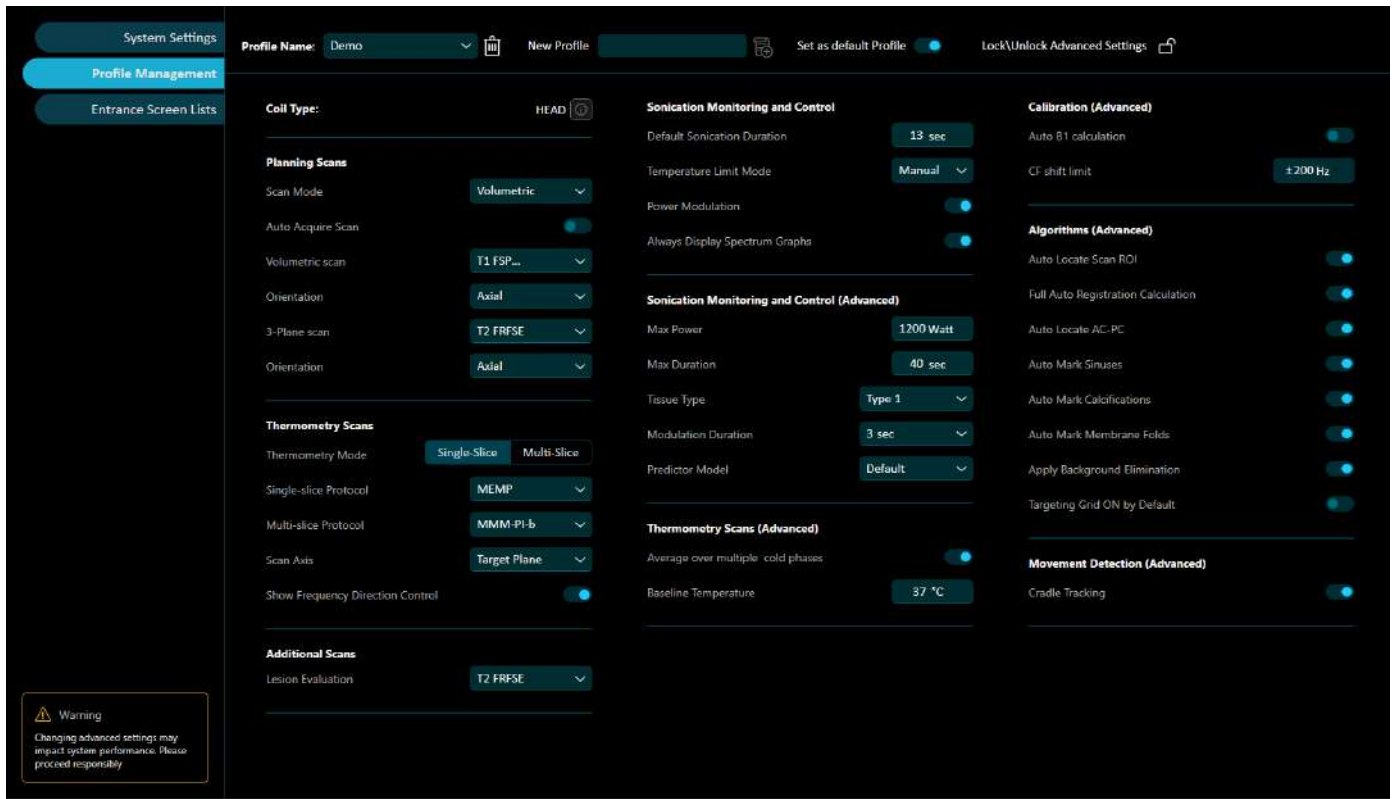

Figure 10-6: Profile Management screen

No.	Name	Description
1.	Profile Name	Existing profiles are located in the Profile Name field. <ul style="list-style-type: none"> Toggle down to select a profile and view/change the selected scan types associated with that profile. To delete an existing profile, toggle and select the profile you wish to delete. Then press the bin button.
2.	New Profile	To add a new profile, type in a profile name and then press the Add Profile button

3.	Set as Default Profile	The default profile is automatically loaded when the system is first powered on. This original default profile is pre-set and non-editable. To set a different profile as the subsequent default, toggle down to the desired profile in the Profile Name field and then toggle the Set as Default Profile slider ON.
4.	Lock/Unlock Advanced Settings	To modify other treatment settings such as Sonication Monitoring and Control, advanced Thermometry scan settings, scan calibration, advanced algorithms, and movement detection, press the lock icon.

10.3.1. Coil Type Display (If applicable)

On 3T systems supporting dual coil options – the profiles displayed shall be aligned with the active coil selection ,as defined in the system settings screen.

10.3.2. Planning Scans

In the Planning Scan Box, it is possible to set the automatic scan parameter that will be defaulted in the specific profile chosen for the treatment. See below.

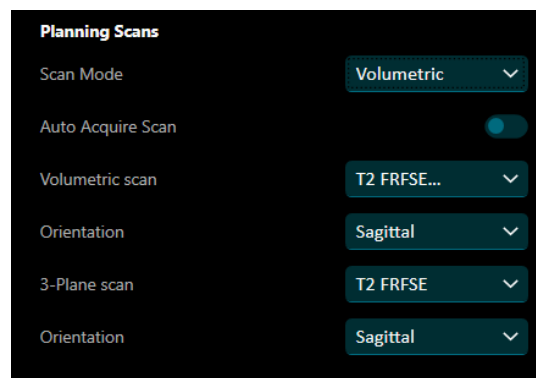

Figure 10-7: Planning Scan Settings

- Toggle down in the **Scan Mode** field to choose between a **Volumetric** or **3-Plane** planning scan acquisition protocol.

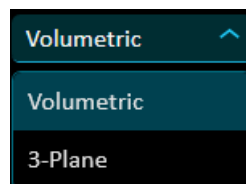

Figure 10-8: Scan Mode Selection

- To have a volumetric planning scan automatically run after the auto calibration is performed, toggle the **Auto Acquire Scan** setting to **ON**.
- For a volumetric scan, choose from the drop-down menu between the different existing scan protocols and set the desired acquisition orientation to axial, sagittal, or coronal.

- For a 3-Plane scan, choose from the drop-down menu between the different existing scan protocols and set the desired acquisition orientation to axial, sagittal, or coronal.

10.3.3. Thermometry Scans



Figure 10-9: Thermometry Scans Settings

- In the Thermometry mode, select either single-slice or multi-slice thermometry protocol.
- For single slice thermometry, choose the required protocol from the drop down menu (if applicable).
- For multi slice thermometry, choose the required protocol from the drop-down menu (if applicable).
- If a PI Calibration scan was performed during a treatment session, PI imaging options will be available in the scan protocol drop-down menus (if applicable).
- Scan Axis – sets the thermometry to image either at the target plane (along AC-PC plane) or along the MR axis
- Show Frequency Direction Control – Toggle the display of the Thermal scan frequency direction toggle. Note this cannot be turned off for single echo thermal protocols.

10.3.3.1. Thermometry Scans (Advanced)

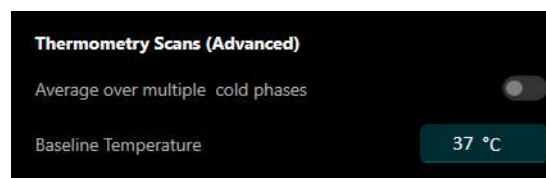

Figure 10-10: Thermometry Scans (Advanced)

- Toggling Average over multiple cold phases ON will cause the system to take an average baseline reading over all pre-sonication phases.
- **Baseline Temperature** – Edit this field to assume a different baseline body temperature. This value should otherwise be defaulted to 37°C.

10.3.4. Additional Scans

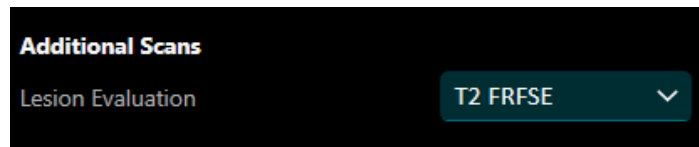

Figure 10-11: Additional Scans

Select a preference scan for type of lesion evaluation (intra-operative) from the drop-down menu.

10.3.5. Sonication Monitoring and Control

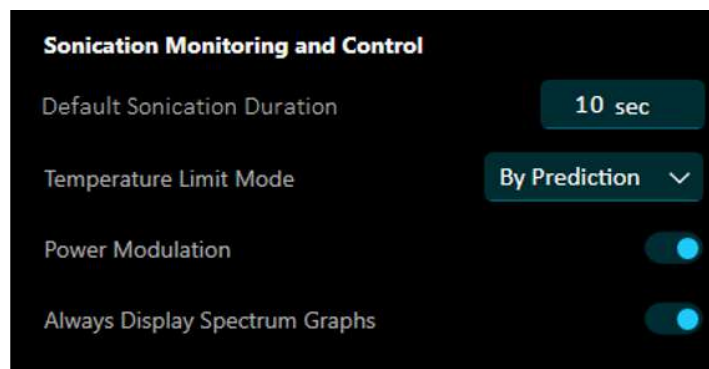

Figure 10-12: Sonication Monitoring and Control

- Choose your preferred default duration for the initial sonication.
- Set preference on temperature limit mode:
 - Toggle between the three Temperature Limit Modes (see subsection **9.4.2.2, Temperature Limit Mode** in section **9.4, The Define Substage**)
- **Power Modulation** – Toggle Power modulation ON/OFF.
 - When ON, the system will reduce power automatically until the acoustic signal falls below the threshold. The system then will try to increase power again while keeping the acoustic signal below the threshold.
 - When OFF the system will automatically stop energy transmission if the acoustic signal crosses the predefined thresholds.
 - Note that the threshold for stopping a sonication on account of cavitation is the same regardless of this toggle's state.
- **Always Display Spectrum Graphs** – Set the toggle ON to have the acoustic signal graphs displayed during a sonication. Toggle OFF to have these graphs hidden during a sonication. Even if the toggle is set to OFF in settings, the user may toggle them back on at any point during the sonication.

10.3.6. Sonication Monitoring and Control (Advanced)

Note: These settings should not be modified without consulting an InSightec representative.

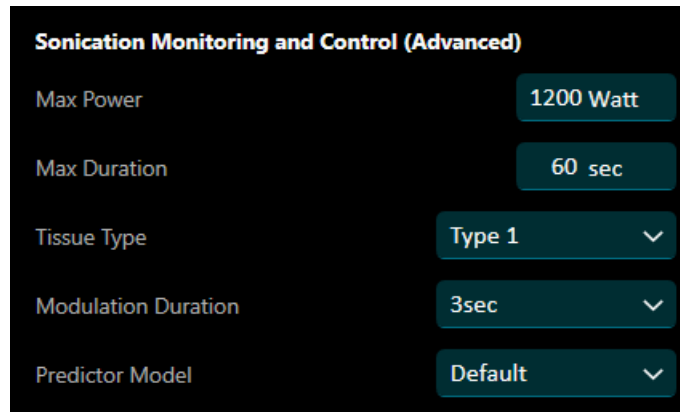

Figure 10-13: Sonication Monitoring and Control (Advanced)

Set the upper limits for sonication parameters (Power and Duration), tissue type, allowed modulation duration, and preferred predictor model.

- **Max Power** – Maximum power allowed to be prescribed for a sonication. This value is set to 1200 Watts by default.
- **Max Duration** – Maximum duration allowed to be prescribed for a sonication. This value is set to 60 seconds by default.
- **Tissue type** – Sets the limit for power modulation as a function of acoustic signal detected.
- **Modulation Duration** – Sets allowable time extension for a sonication that experiences power modulation to reach desired temperature or deliver full amount of energy prescribed.
- **Predictor Model** – Set to Default or Simplified.

The **Default** predictor model provides can suggest Power or Duration and is based on an adaptive temperature prediction algorithm. whereas the **simplified** model is similar to the predictor present in previous Exablate Neuro software versions and is based on a simpler temperature prediction model.

10.3.7. Calibration (Advanced)

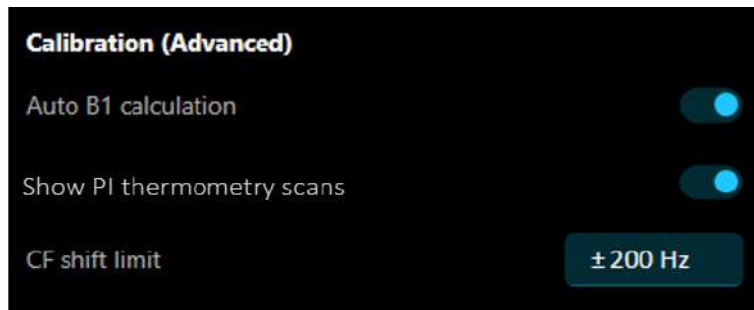

Figure 10-14: Calibration (Advanced)

- **Auto B1 Calculation** – Toggle OFF to disable the B1 calibration. If the auto calibration is performed without the B1 calibration, the B1 cannot be performed during the whole treatment.
- **Show PI Thermometry Scans** – Since calibration is required for PI sequences, they are not displayed in the Profiles screen’s thermometry default drop down menus. To reveal PI thermometry options toggle “Show PI Thermometry Scans” to ON.
- **CF Shift Limit** – Enter desired maximum central frequency shift allowed. If during auto calibration, CF shift is determined to be above this set value, scan will re-run a second time. A CF with a shift above the set value is not accepted and the system will alert in this case.

10.3.8. Algorithms (Advanced)

The algorithm toggle sections allow the user to determine which algorithms will be automatically preformed throughout the treatment flow.

Note that even if toggled off, all algorithms (except auto scan ROI detection) can be run on demand from the Treatment stages' UI.

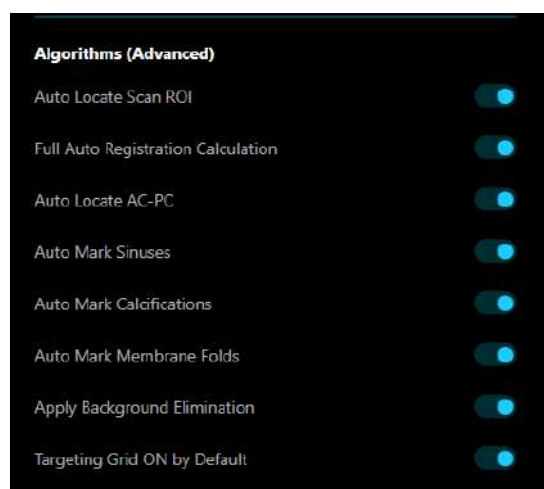

Figure 10-15: Algorithms (Advanced)

- **Auto Locate Scan ROI** – Toggle ON to have the preferred planning scan automatically detect slice range and position.
- **Full Auto Registration Calculation** – Toggle ON to have CT-MR registration automatically run once the patient CT is loaded and the planning scan is complete. Toggle OFF to manually start the auto registration of the CT to MR.
- **Auto Locate AC-PC** – Toggle ON to have AC and PC automatically placed once the planning scan is complete. Toggle OFF to manually place AC and PC on planning scan images.
- **Auto Mark Sinuses** – Toggle ON to have sinuses automatically marked with a no pass region once the CT is loaded.
- **Auto Mark Calcifications** – Toggle ON to have calcifications automatically marked with no pass regions once the CT is loaded.
- **Auto Mark Membrane Folds** – Toggle ON to have membrane folds automatically marked with no pass regions once the membrane fold scan is complete.
- **Apply Background Elimination** – Toggle the initial state of the background elimination algorithm (See 9.6.4.3 Tools Tab)
- **Targeting Grid ON by Default** – Toggle the initial state of the Targeting Grid tool upon entrance to the Targeting Substage.

10.3.9. Movement Detection (Advanced)

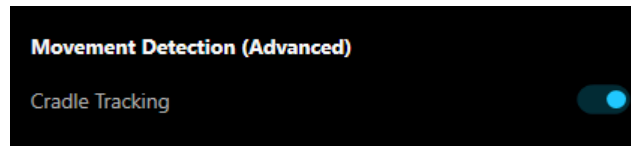

Figure 10-16: Movement detection (Advanced)

Cradle Tracking is another movement detection protocol used with systems that have an STC configuration. Toggle OFF to disable this cradle tracking protocol.

10.4. Entrance Screen Lists

The Entrance Screen List tab enables the user to edit the fields available when the system is first powered on: Username List Management, Target Location List Management and Indication List Management. Refer to the relevant section for more details.

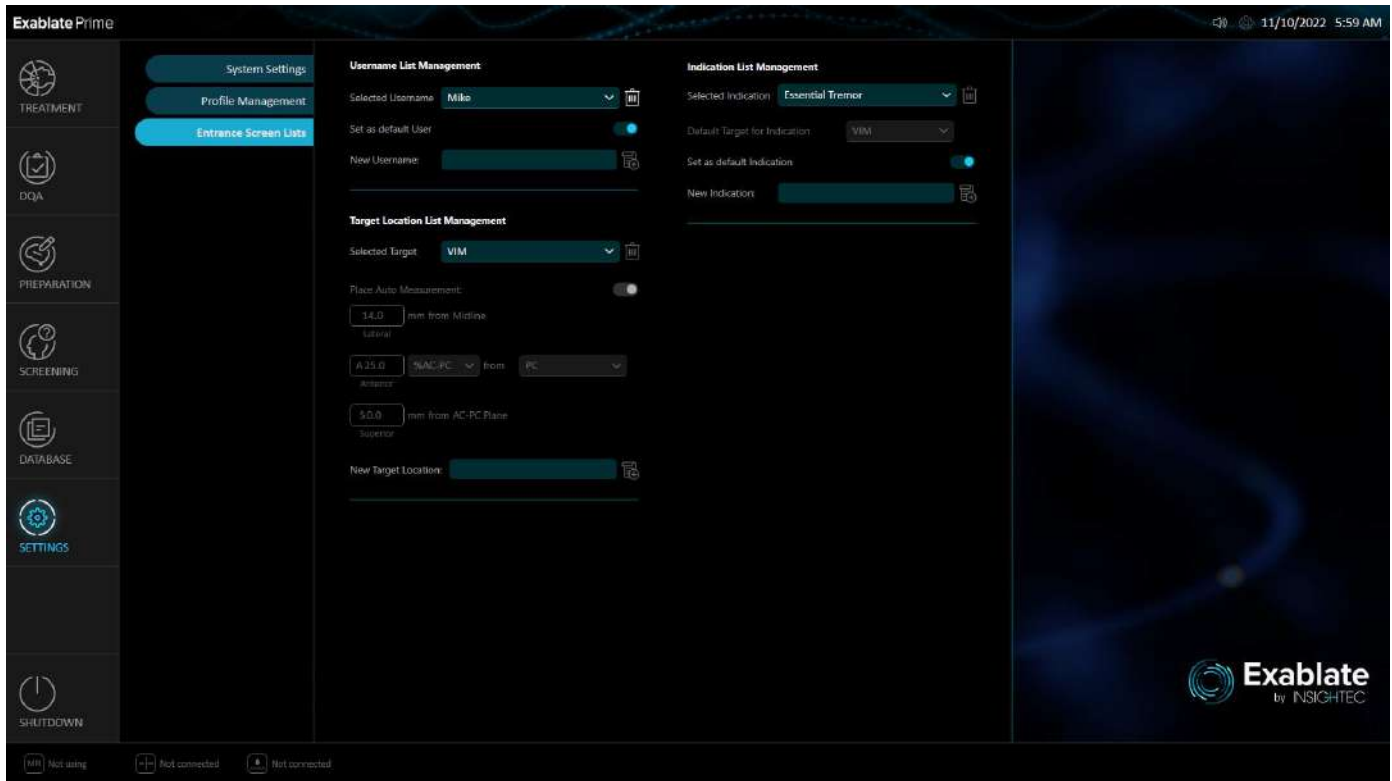

Figure 10-17: Entrance Screen List Management Screen

10.4.1. Username List Management

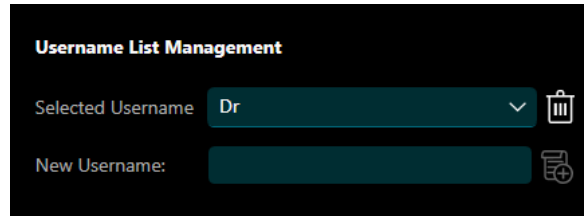



Figure 10-18: Username List Management

- Username refers to the treating physician.
- To delete a username, toggle the dropdown menu for Selected Username, select username to delete, then press the bin icon.
- To add a new username, enter a name into the field and then press the add list item icon. 

10.4.2. Target Location List Management

Define the default coordinates of different anatomical targets in the **Target Location List Management** section.

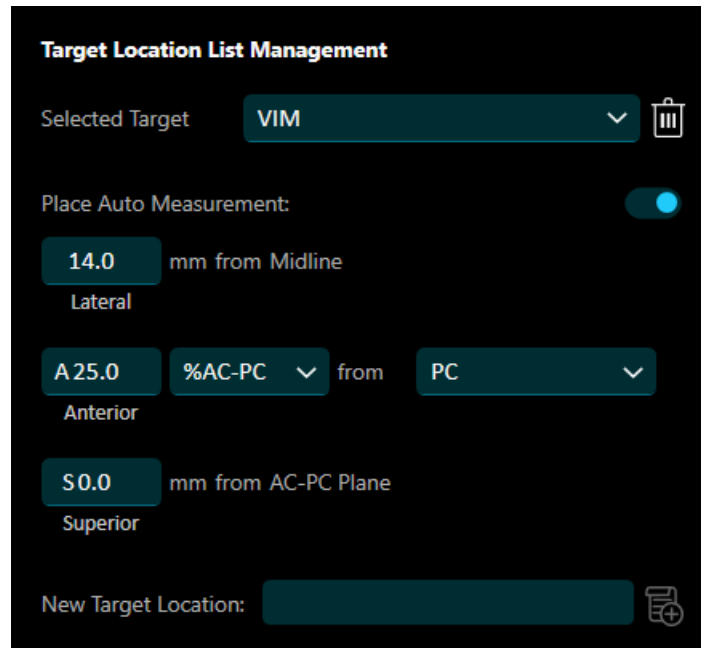



Figure 10-19: Target Location List Management

- To edit the coordinates of a target, select the target from the drop-down menu. Once a target is selected, define laterality, anterior-posterior aspect from PC, AC, or MCP defined by percentage or millimeters, and superior-inferior aspect from the AC-PC plane.

- To add a new target, enter the target name in the New Target Location field then press the add list item icon. 
- To delete a target, select a target to delete from the drop-down menu, then press the bin icon. 

10.4.3. Indication List Management

Define which anatomical targets are associated with different clinical indications under Indication List Management.

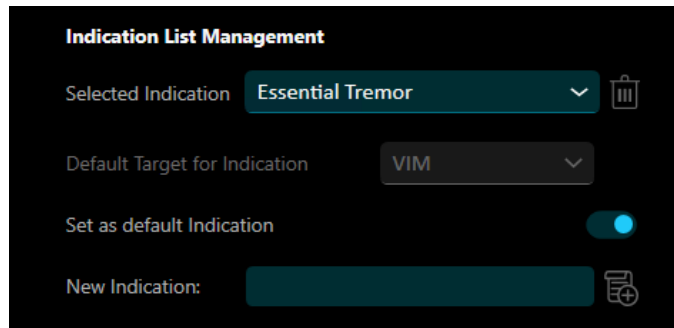

Figure 10-20: Indication List Management

- To change which target is associated with an indication, make sure that the target has been defined under Target Location List Management. Then use the drop-down menu for Selected Indication to select an indication and choose the Default target for Indication.
- Toggle the Set as Default Indication to ON to have the selected indication populate automatically when the system is first powered on.
- To define a new indication, enter the name of the indication in the New Indication field and press the add list item icon.

10.5. System Settings (Treatment Mode)

Settings are accessible from the treatment (Plan & Therapy) and DQA stages.

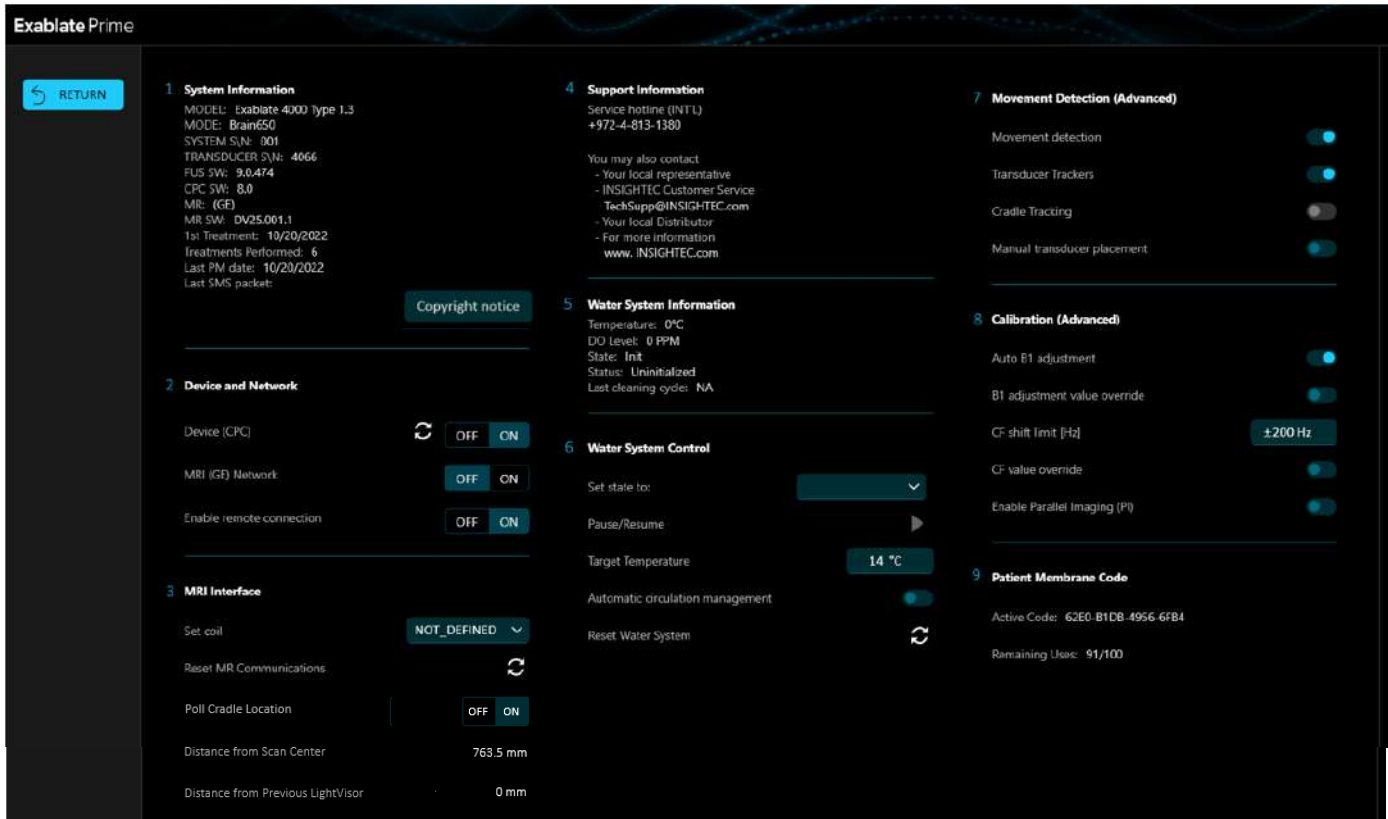

Figure 10-21: System Settings Screen (During Treatment and DQA)

No.	Name	Description
1.	System information	This section shows system information, see section 10.2.1, System Information .
2.	Device and Network	This section enables the user to control Device and Network communication, see section 10.2.2, Device and Network .
3.	MRI Interface during treatment	See Section 10.2.2, MRI Interface As well as an additional option to poll the MR cradles location in PHILIPS systems.
4.	Support Information	This section shows information about system support. See section 10.2.4, Support Information .
5.	Water System Information	This section shows information about the water system, see Section 10.2.5 Water System Information .

6.	Water System Control	This section enables the user to control the water system, see Section 10.2.4, Water System Information .
7.	Movement Detection (Advanced)	See Section 10.3.9, Movement Detection (Advanced) .
8.	Calibration (Advanced)	See Section 10.5.3, Calibration (Advanced) .
9.	Patient Membrane Code	View the current membrane information including: <ol style="list-style-type: none"> 1. The code 2. Remaining uses See Section 3.4.3, Patient Membrane Code .

10.5.1. MRI interface

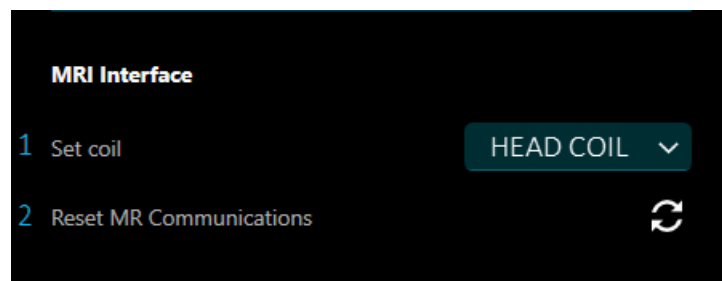

Figure 10-22: MRI Interface Section

10.5.1.1. Set MR Coil

For 3T sites, a default and an alternative coil are defined during the installation process. The **Set Coil** procedure is performed when there is a need to switch between these coils during a treatment. The typical use case would be scanning with the MRs integrated body coil instead of the InSightec Head Coil in case of imaging issues.

- Select the coil you want to use from the drop-down menu; the system will automatically define the MR coil in use as the alternative coil. From this point on, all scans will be performed using the alternative coil.
- To return to the default coil definitions, select the correct coil or exit the treatment.

10.5.1.2. Reset MR Communications

Press the **Reset MR Communications** button to refresh the connection between the FUS WS and the MRI.

10.5.2. Movement Detection (Advanced)

The Advanced Options are not part of the standard flow and changing them can be dangerous for the patient.

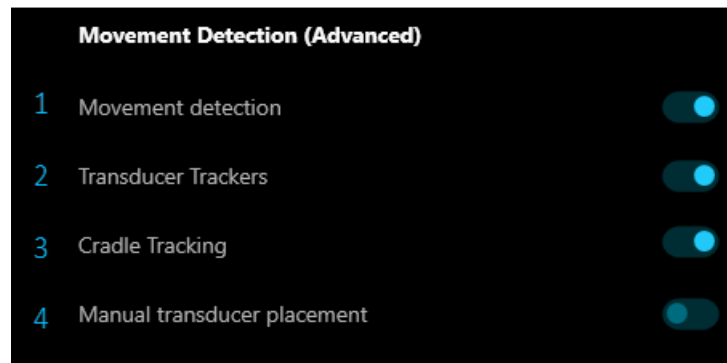

Figure 10-23: Movement Detection (Advanced) Section

10.5.2.1. Movement detection

Movement Detection – toggle this OFF to disable the Movement Detection scan performed before every sonication.



WARNING:

Movement detection is ON by default and turning it off in a clinical setting is strongly discouraged.

W067

10.5.2.2. Disable/Enable Transducer Trackers

The default option is ON. Therefore the **Calibrate** stage will be performed with trackers and a tracker scan will be performed before each sonication.

Press the same button to toggle it **OFF**.



NOTE:

This option should only be used during the treatment in case of repeated tracker scan failures, or repeated occurrences of false transducer movement errors.

N057

10.5.2.3. Disable Cradle Tracking

In setups where cradle tracking is irrelevant, it may be disabled by setting **Cradle Tracking** to **OFF**.

This means that a corrected Helmet System relative coordinate system will no longer be displayed on the MR images, and any change to cradle location will be regarded as Patient Movement. **Patient** and **Transducer Movement Detection** algorithms will remain **Active**.

See subsection **10.5.2, Movement Detection (Advanced)** in section **10.3, Profile** to set the cradle tracking to OFF by Default.



WARNING:

W102

Disabling Cradle Movement Detection increases the risk for miss-targeting and is highly discouraged in a clinical setting

10.5.2.4. Manual Transducer Placement (Research Optional)

If it becomes necessary to perform calibration without relying on tracking information, the calibration can be set to **Manual** mode. In Manual mode the calibration screen buttons are changed accordingly.

This option is for research purposes. For more information, contact your InSightec representative.

10.5.3. Calibration (Advanced)

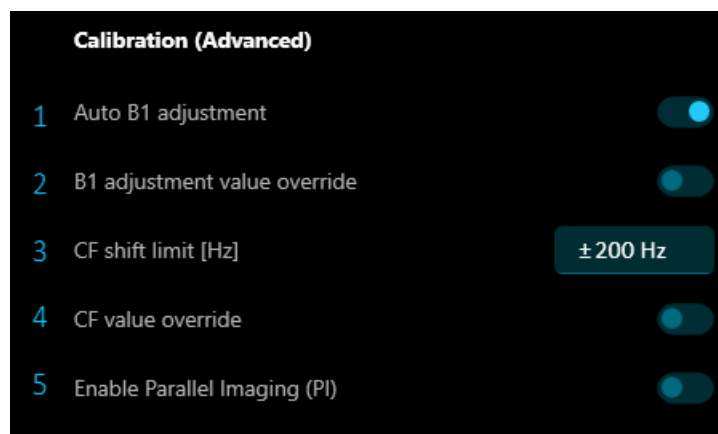

Figure 10-24: Calibration (Advanced) Section

- **Auto B1 Adjustment** – Automatically maps and sets the B1 value for subsequent scans
- **B1 Adjustment Value Override** – If it is determined that the B1 value is best utilized at the same value, toggle ON to manually set B1. Only available if Automatic B1 adjustment has been performed.
- **CF Shift Limit** – If the MR Central frequency scan shift value exceeds this limit, MR Central Frequency scan will automatically run again until the shift value is below the limit. Press the field to modify the CF Shift limit.
- **CF Value Override** – Override the shift value found during the normal MR Central frequency scan.
- **Enable Parallel Imaging (PI)** – Enables the acquisition of a PI calibration scan. Once the calibration scan was performed, PI-supporting thermal scans will be seen in the list during treatment.

10.5.4. Exit System Settings (Treatment)

To leave **Settings**, press the **RETURN** button on the side of the screen; the system will transition to the stage that was active prior to entering **Settings**.

This page is intentionally left blank for double-sided printing.

11. REPLAY MODE

11.1. Overview

Two Replay Modes are available:

- **Online:** Replay of previous sonications during an active exam, accessed from the treatment itself while the treatment is still active. See Section **11.3, Online Replay**.
- **Offline:** Replay of a previous treatment session can be accessed from **Data Management** by selecting and double clicking it (see the **DATA MANAGEMENT** Chapter and the **Offline Replay** Section).

For both modes, once **Replay mode** is initiated, the screen will appear similar to the **Review Substage** in the **Therapy Stage** (As Replay mode is purely an observation mode, tools such as spot adjustment correction or peak temperature update are no longer available, and Evaluation comments may not be edited) screen displaying the results of the last performed sonication. This way the operator can observe the acquired temperature maps and the temperature graph of all previous sonications.

Note that some edit tools in replay are no longer available.

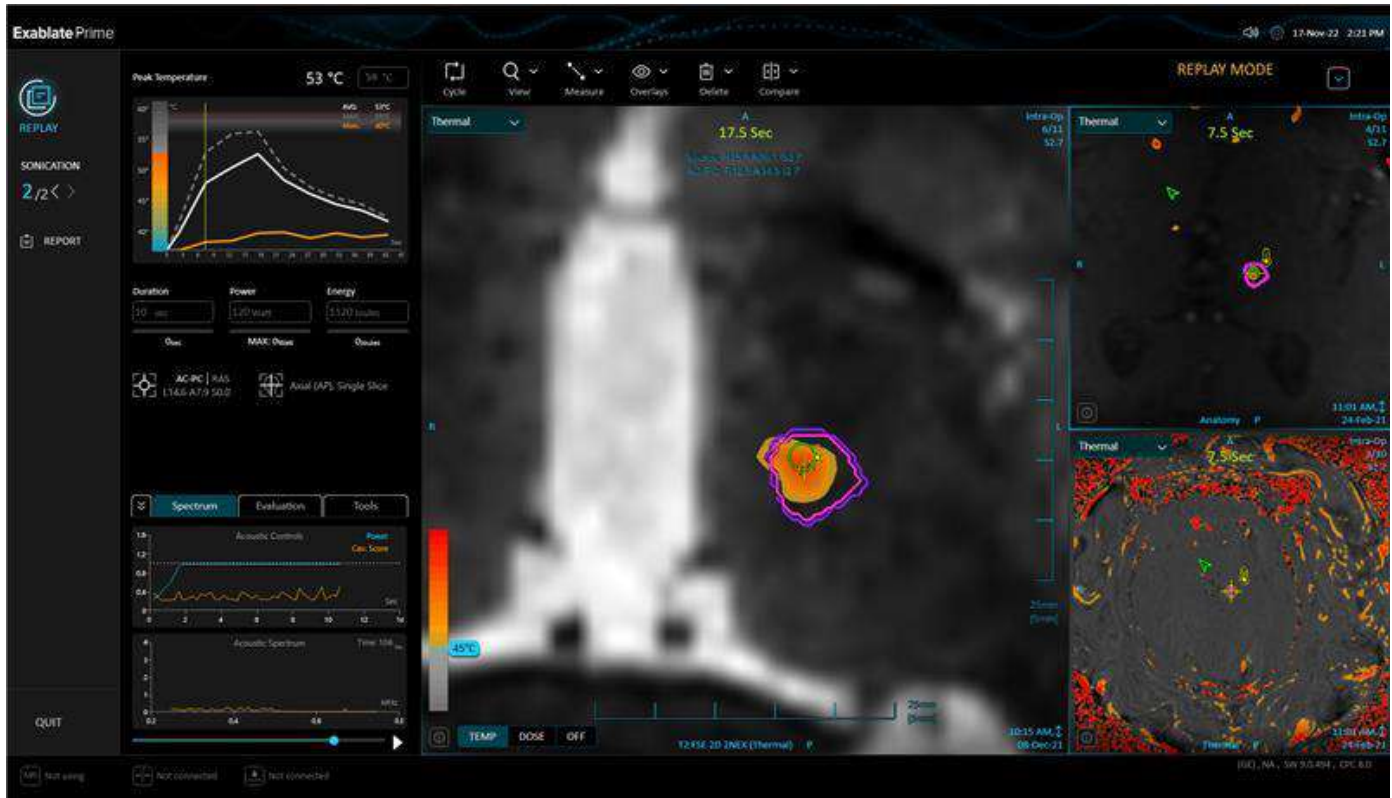

Figure 11-1: Offline Replay Screen

11.2. Replay Toolbox



Figure 11-2: Replay Toolbox

No.	Name	Description
1.	Sonication Traceability	This field displays the total number of sonications as well as the currently shown sonication number on the Replay screen. Press the arrow buttons to cycle between the sonications.
2.	Return Button	Button available only in Online Replay. Press this button to leave the Replay screen and go back to the previous screen.
3.	Report Button	Press this button to access the Summary Treatment Report.

11.3. Online Replay

Online Replay mode enables the user to analyze the results of previous sonications performed during the therapy stage of the active exam.

11.3.1. Enter Online Replay

To access replay mode during a treatment, press the **Replay** button underneath the sonication cycle graphic on the left-hand side. 

Alternatively, press the back arrow next to the current sonication number.

11.3.2. Exit Online Replay

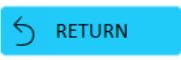
To leave **Replay**, press the **Return** button ; the system transitions to the same screen from where you accessed **Replay**. Alternatively, use the forward arrow next to the sonication number to go back to the current sonication prescription screen.

11.4. Offline Replay

Offline Replay enables the user to review prior treatments that were performed and saved to the database or that were imported into the system.

11.4.1. Enter Offline Replay

To access the Offline Replay, open the Database Subsection in the Navigation Bar.

Select a treatment from the list and click on the 'Load Replay' button to load a previous treatment session (see section **13.1.1, Select Database** and the Section **13.1.2, Main Database Window**).

Double-click on a previous treatment session to open the summary report (if available).

When accessing **Replay** from **Database**, the **Replay** screen displays the first sonication in the treatment.

11.4.2. Exit Offline Replay

To exit the offline Replay, press the 'Quit' button. You will be directed back to the Database screen.

This page is intentionally left blank for double-sided printing.

12. CLEANING AND DISINFECTION

12.1. Cleaning/Disinfection Materials

CLEANING OF THE EXABLATE SYSTEM REQUIRES THE FOLLOWING:

Transducer and Water System Disinfection

50mL (e.g. two 25ml bottles) of Sodium Hypochlorite (CAS # 7681-52-9) 4.00 - 4.99%, for disinfection and maintenance of the Exablate Water Tank, Water System and Transducer

The disinfection solution should include only Sodium Hypochlorite as the active material, without additional active ingredients (bleach, for example, is not suitable).



CAUTION:

C043D

Use of materials that deviate from the above instruction may result in system damage and reduced performance.



NOTE:

N084

Contact your InSightec representative for more information or if assistance is needed in acquiring the required cleaning materials.

Surface cleaning & disinfection

One package of (at least five) Disinfecting wipes, containing 0.2 - 0.4% of benzalkonium chloride (CAS # 8001-54-5) for use in cleaning and disinfecting the Silicone Cover, Transducer and Exablate Accessories (see below).



NOTE:

N085

The surface cleaning/disinfection procedure must be performed after completion of each patient treatment.



CAUTION:

C032

It is recommended to wear personal protective equipment (i.e. gloves) when handling the membrane and performing the cleaning procedure (handling system components, cleaning solution and wipes)

Head frame cleaning

- Medical Alcohol IPA 70% (isopropyl alcohol 70% in water)
- Purified water complying with ISO3696 (1987) Grade 2, or ASTM (D1193-91) Type II, or NCCLS (1988) Type II or equivalent.
- Lint free cloths

12.2. Patient Membrane and Coil Handling Procedure

Patient membranes and Coils are provided non-sterile and are intended for single-use only. Discard of membranes, coils and their storage box after each use according to the local/site procedures.

12.3. Exablate MRI Adapter baseplate, HS and Table Cleaning Procedure

As the MRI table falls within the confines of a non-sterile healthcare environment, InSightec expects the table to be covered with a cover for each patient.



NOTE:

N086D

The cover and table should be handled according to institution requirements.

Step1. Prior to the cleaning process, transfer the Helmet System to the Storage and transfer cart

Step2. Use paper towels or a cloth to absorb soak up and wipe any excess water that may have accumulated in the baseplate basin and finish off by wiping the baseplate surface with a disinfecting wipe (specified in Section **12.1, Cleaning/Disinfection Materials**)

Step3. Disconnect and stow Adapter Baseplate

Step4. Use the dedicated surface cleaning and disinfection wipes specified in Section **12.1, Cleaning/Disinfection Materials** to thoroughly wipe all exposed surfaces of the Helmet System, Frame and the Frame holding posts



NOTE:

N087

After removing the Helmet System from the MR Table, the MR may be used while the cleaning process is ongoing.

12.4. Transducer Handling Procedure

After each procedure or cleaning cycle, wipe dry all surfaces of the transducer with dry lint free cloth. See **Figure 12-1**. Use extreme care to avoid scratching the elements.



Figure 12-1: Transducer Handling Procedure

12.5. Transducer and Water System Disinfection Procedure

Periodic cleaning and disinfection of the Transducer and the Water System Piping and Reservoir is required. The procedure must be performed once five patients have been treated, or in case over seven days have passed without cleaning following a treatment. A general recommendation would be to perform the cleaning cycle at the end of every treatment day. Follow the following steps:

- Step 1: If off - turn on the Water System.
- Step 2: Verify that the Transducer is completely empty from water or soil. If not, drain it of water and/or clean visible soil with the provided cleaning and disinfection wipes (specified in Section **12.1, Cleaning/Disinfection Materials**).
- Step 3: Clean the DQA Cover with disinfection wipes and seal it to the transducer. Make sure to lock the cover with all the clamps around the Transducer frame.
- Step 4: Open the compartment of the water tank in the water system by opening the water tank compartment door. See **Figure 12-2**



Figure 12-2: Transducer and Water System Disinfection Procedure

Step 5: Disconnect the pipes. see Figure 12-3.

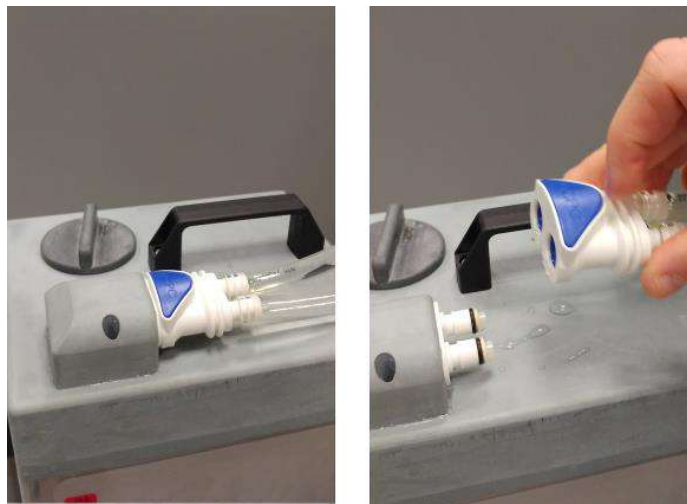

Figure 12-3

Step 6: Open the cover of the water tank. see Figure 12-4.

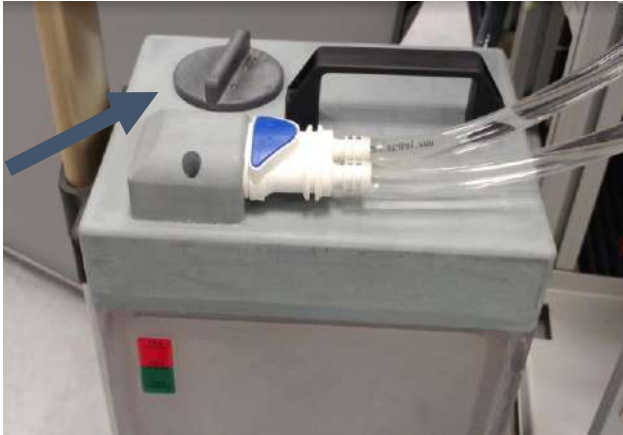

Figure 12-4

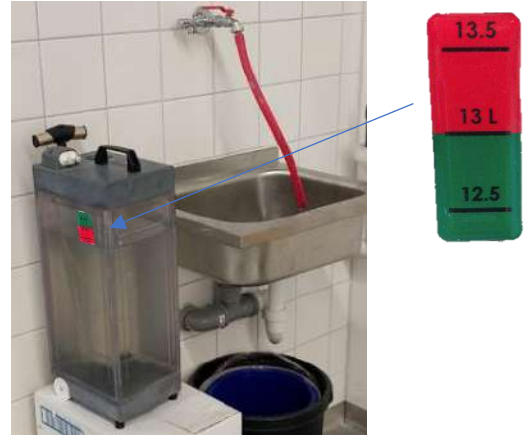

Figure 12-5

Step 7: Dispose of the water in the tank by pouring it into a sink or water disposal vessel. Place tank upside down and make sure it is completely empty and verify visually.

Step 8: Fill the tank with fresh Reverse Osmosis water (or purified water complying with ISO3696 (1987) Grade 2, or ASTM (D1193-91) Type II, or NCCLS (1988) Type II or equivalent) at room temperature (15-25°C). Use the fill line marking on the reservoir. **See Figure 12-5.**

Step 9: Pour 50ml of Sodium Hypochlorite (CAS # 7681-52-9) 4.00 - 4.99%, into the **Water Tank**.



NOTE:

N089D

Store and handle the cleaning solution according to manufacturer specifications.

Step 10: Re-connect the pipes to the tank and place in its compartment in the Front End.

Step 11: Make sure that the water system hose is connected to the Front End. See **Figure 12-3**



Figure 12-6

Step 12: On the Water system main screen – ‘Home’ Menu (Figure 12-7), press the ‘Clean’ option
The system will switch to Clean Mode (Figure 12-8)

NOTE: If not at home screen, press the ‘Home’ button

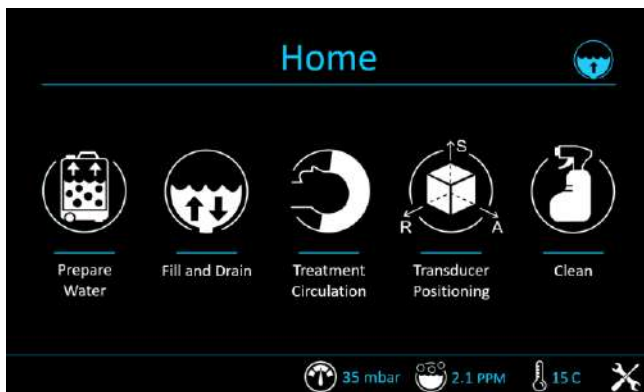

Figure 12-7: 'Home' Menu

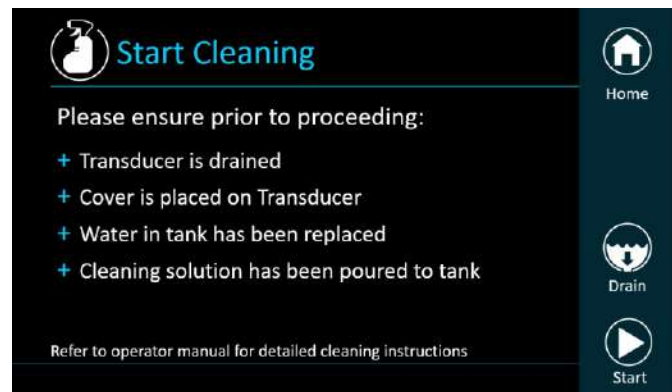

Figure 12-8: 'Clean' Menu

Step 13: Press ‘Start’ button to start the cleaning operation (Figure 12-8). A countdown timer will appear, displaying the remaining Tank cleaning time (Figure 12-9)

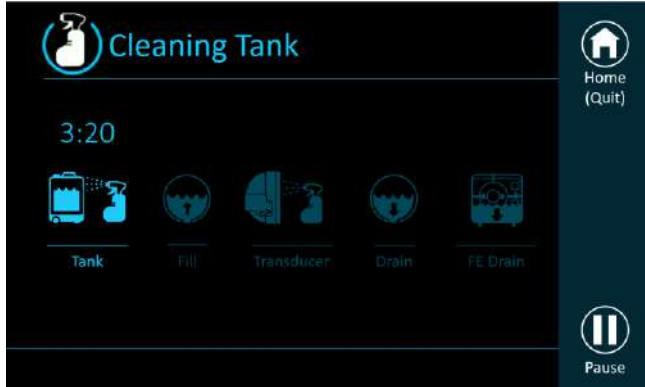

Figure 12-9: 'Cleaning Tank'



Figure 12-10: Fill & Clean Transducer' Screen

Step 14: Once the timer reaches zero, a completion sign appears (**Figure 12-10**) and the system is ready for the next stage of the Cleaning cycle – Fill & Clean Transducer

Step 15: Verify that the Transducer is connected to the water system connector at the Front End.

Step 16: Open the Valve on top of the Transducer to enable air flow while the Transducer interface is filled with water. See **Figure 12-11**



Figure 12-11: Air Release Valve (open)

Step 17: Fill the transducer via the Fill button on the interface or the Water System Remote Controller.

(**Tip:** bringing the Transducer to an inferior position reduces the required volume for filling the Transducer interface, shortening filling time)

Step 18: Close the Valve once the transducer is full

Step 19: Press 'Resume' on Screen or on 'circulate' on Remote Controller (**Figure 12-13**) to start 'Cleaning Transducer' timer.



Figure 12-12: 'Cleaning Transducer'



Figure 12-13: Water System Remote Controller

Step 20: When timer is over, transducer cleaning is complete.

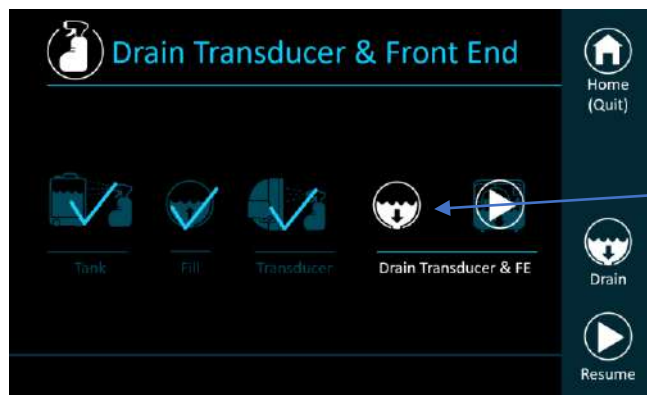

Figure 12-14: 'Drain Transducer & Front End'

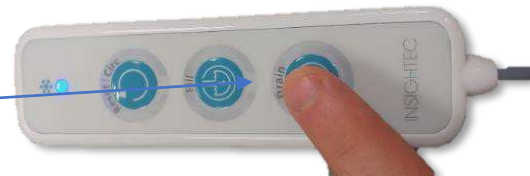

Figure 12-15: Drain

Step 21: Set the Release valve to air.

Step 22: Drain the water from the transducer using the screen or the remote (**Figure 12-15**).

Note: If utilizing multiple water tanks, see **section 12.5.1**

Step 23: When transducer is empty, Drain the water from the Front End using the screen or the remote. A countdown timer will appear, displaying the remaining Front End draining time.

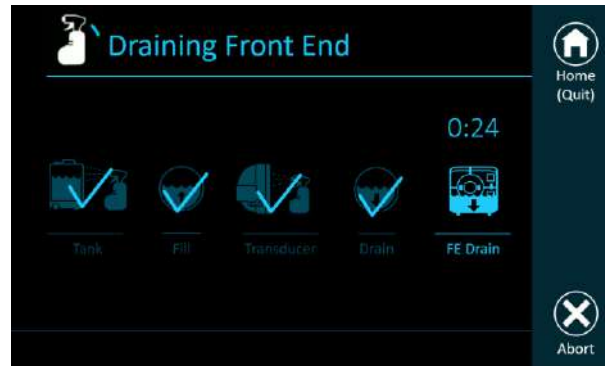

Figure 12-16: 'Draining Front End'

- Step 24: Dispose the water from the water tank according to local regulations and leave the Tank open to air (Without valve).
- Step 25: Remove the sealing from the transducer-patient interface.
- Step 26: Release and remove the DQA Set-up from the transducer (**Figure 12-18**).
- Step 27: Dry it using paper towels or a rag

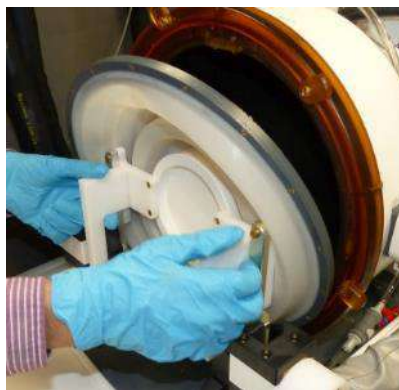

Figure 12-18



Figure 12-17

Clean the Protective Cover (**Figure 12-18**) with dedicated cleaning and disinfection wipes (specified in Section 12.1, **Cleaning/Disinfection Materials**).

- Step 28: Protect transducer surface using the protection cover (**Figure 12-18**). Verify Transducer valve is still open, to avoid over pressure, and so that transducer can dry freely.



NOTE:

a residual water quantity of up to 1L may remain in pipes. This will be flushed out from system as part of the start-up cleaning/circulation prior to treatment set up.

N090

12.5.1. Auxiliary water tank cleaning

In the event where multiple water tanks have been used during the treatment day, the following cleaning recommendations are provided.

Option A

During the cleaning procedure, before step 22, replace water tanks, and drain the water into the tank that has NOT undergone the tank cleaning cycle. Let the water stand for 6 minutes or more, and dispose of the water.

Option B

Fill the tank with fresh water and Pour 50ml of Sodium Hypochlorite (CAS # 7681-52-9) 4.00 - 4.99%, into the tank. Let the water stand for 6 minutes or more, and dispose of the water.

12.6. Head Frame Cleaning Procedure

Use the following guidelines to maintain Head Frame components after each treatment:

1. Immediately after use, wipe components with de-ionized distilled water to remove any residue of Betadine and blood or other debris.
2. Dry thoroughly the components with paper

For a more thorough cleaning (e.g., persistent stains), follow the guidelines below to maintain the Head Frame components:

Cleaning procedure steps:

1. Disassemble the head frame base from its posts using the dedicated head frame assembly wrenches.
2. Spray all over the Head Frame components (base and posts) with IPA 70% till their surface are visibly wet and expose for 6 minutes. Pay extra attention to the screws' dedicated holes.
3. Wipe the Head Frame components using 2 lint free cloths soaked with the purified water for at least 4 minutes.
4. Spray again all over the Head Frame components thoroughly with IPA 70%.
5. Wipe the Head Frame components using 2 lint free cloths soaked with the purified water for at least 2 minutes.
6. Wipe the Head Frame components to dry using the dry lint free cloths.



CAUTION:

Do not use saline. Saline may cause damage to the metal surface.
Do not use corrosive agents, such as Clorox® or Cidex®.

C005



NOTE:

The use of Betadine® or similar solution containing iodine may stain the surface of the Head Frame. To minimize discoloration, wipe off any traces of Betadine® or similar solutions as soon as a possible during or following the procedure.

N008D



NOTE:

If instruments are exposed to highly caustic solutions such as bleach solutions, immediately rinse the instruments with de-ionized distilled water to prevent corrosive damage to surfaces and moving parts.

N009D



CAUTION:

C006

Headframe expected life cycle is 5 years. Contact your InSightec representative regarding replacement Frame, discard according to local regulations following said period and in case of any visual signs of damage/ corrosion.

Exablate Head Frame – Recommended Autoclave Parameters (optional procedure):

Headframe components are Autoclave compatible.

The Head Frame should be disassembled prior to autoclave process.

Place the components in adequate autoclave bag, i.e., Sterilization Pouches.

The following table provides the recommended autoclave parameters for the Exablate head frame and components:

Steam Autoclave		
	Option 1	Option 2
Temperature	250°F / 121°C	270°F / 132°C
Exposure Time	20 minutes	10 minutes
Dry Time	20 minutes	10 minutes

While the components may undergo the above autoclave process, the Head Frame and its components are not considered “Sterile” after this process.



CAUTION:

C043D

Use of materials that deviate from the above instructions may result in system damage, cross-contamination risk, and reduced performance.

This page is intentionally left blank for double-sided printing.

13. DATA MANAGEMENT

13.1. Database Overview

The database enables the user to observe (See REPLAY MODE Chapter) previously performed treatments and DQA sessions. It also enables the user to perform database actions such as screenshot, treatment and session export/import and delete.



NOTE:

This mode can be accessed only from the **Main screen** and not during treatment, by pressing the **DATABASE** button. N091

To replay a session from the Database screen, refer to the **REPLAY MODE** Chapter.



Figure 13-1: Database Screen Overview

No.	Name	Description
1.	Main Database Window	The main database window is a table platform enabling to search and watch the recorded sessions, screenshots, and summary table from each tab (when available). See Section 13.1.2, Main Database Window .
2.	Database Tabs	The Database is sorted to 3 different table tabs: <ol style="list-style-type: none"> 1. Treatments 2. Screening Calculations 3. Planning Sessions 4. DQA Sessions Press on the tab from which you would like to import data. See Select Database Section.
3.	Database Toolbox	The Database Toolbox include the Import/Export tools. See Database Toolbox Section

13.1.1. Select Database

There are three tabs to select the database from.

Press the **Treatments** tab to display the **Database** data including all the treatments performed/ imported.

Press the **Screening Calculations** tab to display the **Database** data including all the screening calculations performed and saved.

Press the **Planning Sessions** tab to display the **Database** data including all the planning sessions performed/ imported.

Press the **DQA Sessions** tab to display the **Database** data including all the DQA Sessions performed/ imported.

In each tab, use the main database window options to find the session/s:

1. Hold down the **Shift** key to select a continuous list of sessions.
2. Hold down the **Ctrl** key to select specific patient IDs.

13.1.2. Main Database Window

The main database window is a table platform enabling to search and watch the recorded sessions, screenshots, and summary table from each tab (when available).

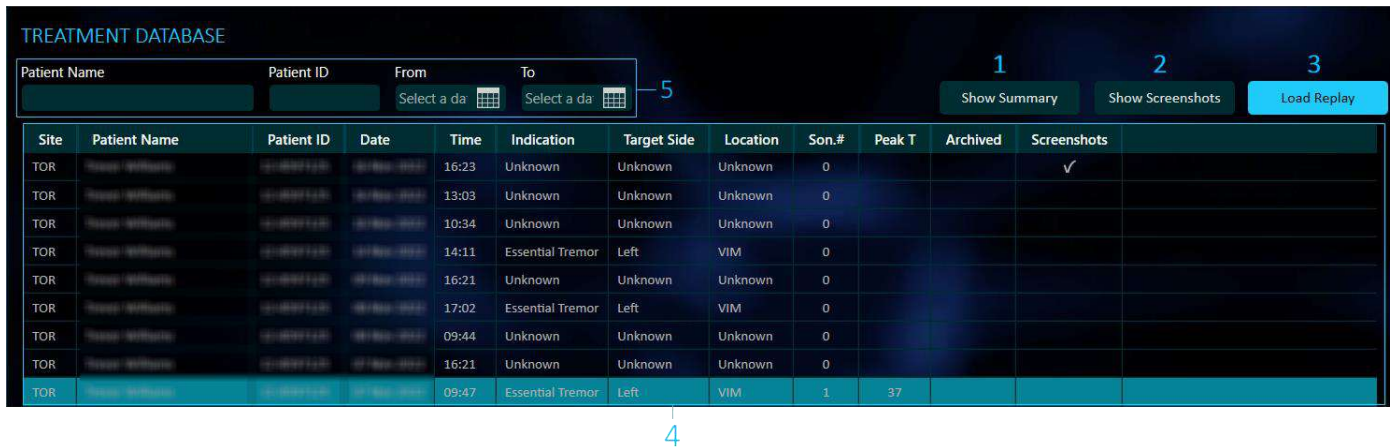

Figure 13-2: Main Database Window

No.	Name	Description
1.	Show Summary Button	Press this button to open the treatment summary table. See Treatment Summary Table section.
2.	Show Screenshots Button	Press this button to open a screenshots screen.
3.	Load Replay Button	Press this button to open the Replay Dialog Box. See the REPLAY MODE Chapter.
4.	Database Table	The database table displays all the sessions done or previously imported.
5.	Patient Fields	The following fields can help in filtering, search and finding a specific session from the database. Patient Name Field, Patient ID Field, From and To a date fields.

13.1.3. Treatment Summary Table Report

The **Treatment Summary Table** includes various treatment details, as well as a full list of the sonications performed and their various properties.

selecting a specific row highlights that sonication and pressing the "Show Sonication" button enables observing it directly in **Replay** mode (online/offline, depending if navigating to the Summary Table from a treatment's **Therapy** stage or from the **Database** screen).

While individual sonication's comments are not editable, the "Treatment Summary" and " Database Comment line" fields at the bottom of the summary may be edited and amended at all times.

A simple file containing all the information in the sonication table can be exported. See section **13.1.6, Export Data**.

The screenshot displays the 'TREATMENT SUMMARY TABLE' interface. On the left, there are several summary cards for patient information (Anon), physician (Anon Doc), treatment date (01-Jan-01), indication (Essential Tremor), and various technical parameters like SDR (0.54) and skull area (341 cm²). The main part of the screen is a table with 10 columns: Row, Time, Target [AC-PC], Target Change, Parameters, Scan, Peak Temp, Method, and Comments. Six rows of sonication data are listed, with the third row highlighted in blue. A 'Show Sonication' button is located in the top right corner. At the bottom, there are fields for 'Treatment Summary' (containing 'Tremor resolved, no residual paresthesias') and 'Database Comment Line'.

Row	Time	Target [AC-PC]	Target Change	Parameters	Scan	Peak Temp	Method	Comments
1	13:43:45	L15.0 A6.4 52.0 (1)		Req: 10s x 311W, 279J Del: 10s x 308W, 2822J	MEMP OAx (AP)	Average: 45°C Max: 47°C		
2	13:46:07	L15.0 A6.4 52.0 (1)		Req: 10s x 232W, 2091J Del: 10s x 228W, 2114J	MEMP OAx (RL)	Average: 42°C Max: 45°C		
3	13:48:48	L15.0 A6.4 52.0 (1)		Req: 14s x 503W, 6595J Del: 14s x 498W, 6542J	MEMP OCor (RL)	Average: 52°C Max: 54°C		
4	13:55:54	L15.0 A6.4 52.0 (1)		Req: 17s x 700W, 11353J Del: 17s x 657W, 10852J	MEMP OCor (RL)	Average: 55°C Max: 59°C		Spot shape vastly improved after mask application. sig tremor improvement without side effects.
5	14:01:47	L15.0 A6.4 52.0 (1)		Req: 23s x 293W, 17539J Del: 19s x 724W, 13408J	MEMP OCor (RL)	Average: 57°C Max: 60°C	Thermal loop	mild-moderate paresthesias corner of mouth and fingertips, good tremor reduction.
6	14:09:04	L15.0 A7.4 54.0 (2)	R0.0 A1.0 52.0	Req: 26s x 752W, 18715J Del: 13s x 742W, 13381J	MEMP OAx (AP)	Average: 58°C Max: 65°C	Thermal loop	paresthesias resolved and good tremor control.

Figure 13-3: Treatment Summary Table Screen.

13.1.4. Database Toolbox

The Database Toolbox assemble the Import/Export management tools. The Database Toolbox remain the same for each of the database tabs (Treatments, Planning or DQA Sessions).

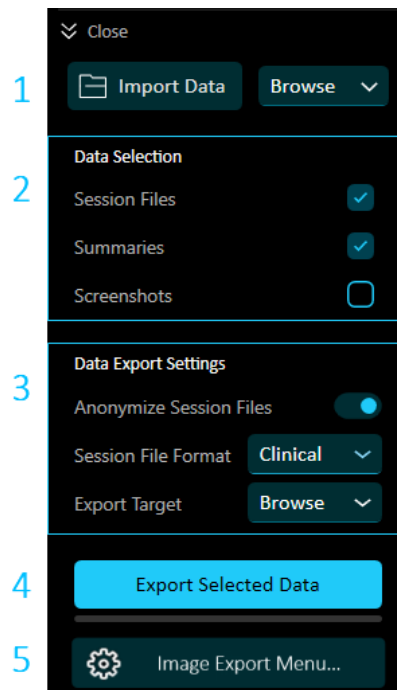

Figure 13-4: Database Pull-Up Toolbox

No.	Name	Description
1.	Import Data Button	Press this button to import one or several Session records that have been previously saved on a CD, USB flash drive or shared folder to the console, or treatments from another Exablate console. Import Data button is available on all Database screens. See Section 13.1.5, Import Data.
2.	Data Selection	Select the data from the following options you want to include into the Export. <ol style="list-style-type: none"> 1. Sessions files 2. Summaries – Treatment summary tables file. 3. Screenshots taken using the screenshot tool available during the treatment, see TOOLS & OVERLAYS Chapter.
3.	Database Export Settings	Chose the settings for managing the data export, See section 13.1.7, Database Export Settings.

4.	Export Selected Data	Press this button to export all selected treatment records to the CD or USB flash drive or a Shared Folder. See Section 13.1.6, Export Data
5.	Image Export Menu	Press this button to enter the Image Export Menu dialog box. Images imported can be copied using the Exablate CD drive, USB flash drive or to a shared folder. See Section 13.1.8, Image Export Menu .



NOTE:

N095

- The Exablate system enables back-up storage of treatment data on certain electronic media (CD, DVD, USB or external HDD); however, it is the responsibility of the user, not InSightec, to back-up treatment data as may be required by applicable laws and regulations and/or by the user's institutional policies and procedures. The back-up storage capabilities on the Exablate system are provided by InSightec 'as-is' without any representations or warranties, including but not limited to warranties of merchantability and fitness for a particular purpose.
- InSightec is not responsible for any data alteration or loss arising from malfunction, or any use of, electronic media used with the Exablate system.

13.1.5. Import Data

The user can load previous Treatment/ Pre-Planning Session or DQA Session for viewing or use during treatment, by pressing the Import Data button. The data needs to be an export and can be loaded from a DVD, USB or a Shared Folder.

1. Place the CD with the treatment files in the DVD drive or connect the appropriate USB device.
2. Select from the drop-down menu the right source (**DVD, USB or Shared Folder**) from where to import the selected Export.
3. Press the Import Data button.
4. Select the treatment/s you want to import from the import list.
5. Press the Import Button. The status of import process is shown next to each selected session. (e.g. progress bar of Not Enough Disk Space).

The imported exports will be copied to the local drive and will be shown in their according Table.



NOTE:

N059D

File retrieval form external sources such as DVD or USB may be slower than expected.

13.1.6. Export Data

Export one or more Sessions records from the local database to a CD, USB storage device or a shared folder as follows:

1. Insert a blank CD into the CD drive or connect a USB flash drive.
2. Select the desired Database Tab. See Section **13.1.1, Select Database**.
3. Select a Session or a set of sessions to export from the main database window. See Section **3.5, Main Database Window** From the database toolbox, data selection; select the desired data from the sessions to import (Session Files, Summaries or Screenshot). See Section **13.1.4, Database Toolbox**.
4. From the database toolbox, Data Export Settings; select the desired settings (anonymize data toggle button, Session File Format and Export Target drop down menus). See Section **13.1.7, Database Export Settings** Press Export Selected Data.

Data will be exported to the CD or USB device to the chosen source.



NOTE:

N059D

File retrieval from external sources such as DVD or USB may be slower than expected.

13.1.7. Database Export Settings

Before exporting, chose the right settings exports:

1. The System enables to export each dataset separately with or without anonymization.

The system creates separate database sets for clinical and for technical use. Each set can be exported separately.

The **Clinical Dataset** contains only the data needed for playback and treatment summary as well as screenshots captured and the main treatment log.



The **Technical Dataset** contains any logs and data which might help in post analysis of the treatments or in analysis system health.

2. Choose from the drop-down menu: Technical, Clinical or Combined.
3. Choose from the drop-down menu the export target, where the data will be saved (DVD, USB or a Shared Folder)

13.1.8. Image Export Menu

The Exablate system is equipped with a utility to export MR images to the CD, USB flash drive or a Shared Folder.

To export MR images.

1. Press the Image Export Menu button to open the Image Export Menu. 
2. Select image source and target from the drop-down menus; the download MR Images dialog box appears.
3. Select the desired Exam List
4. From the associated Series List select one or more series. To select entire study, right click it and click "Select Entire Study." The exam shall appear in the thumbnail bar.
5. Type in a new patient name and treatment ID or use the system default (patient's initials).
6. Press the **Export** button to copy the images to the chosen destination 
7. The CD is automatically ejected from the CD drive when the data export is complete.

13.1.9. Treatment Archive

The Exablate system can be delivered with an additional external database. The optional database can be added to an existing system by InSightec at a later stage as well.

The access to the external database is done from the **Application Selection Menu** in the **Main Screen**, in

form of a distinct application: 

See **Section 3.4, Application Selection Menu**.

13.2. Cyber security

13.2.1. Overview



CAUTION: C034
Only authorized personnel is allowed to physically access the Exablate System.



CAUTION: C035
Maintain physical access control to the MR control room and the Exablate System



CAUTION: C036
Maintain physical access restriction to the MR service area and the Equipment Cabinet.



CAUTION: C017D
Exablate Workstation username & password should not be printed or shared with anyone.



NOTE: N092
It is recommended to contact your InSightec representative to modify the initial password and replace it with a strong password which fits your local password policy.



CAUTION: C037
In case the WS and/or CPC hard drive/s physical security cannot be guaranteed in the MR control room or the Equipment Cabinet room, detach with the dedicated keys the WS and/or CPC hard drive/s when the system is not in use and store them in a safe and accessible controlled location.



NOTE: N076D
The two USB ports located on the front side of the Operator's console are only intended for import & export treatments data.



WARNING: W104
USB devices should be used on Exablate workstation only by authorized personnel. USB devices require prior malware scan (by Anti Virus /Anti Malware).

Do not use the USB port to charge other equipment.

Do not insert unauthorized devices into USB ports, including radiofrequency (RF) transmitters.



NOTE:

N093

It is recommended to use caution when transferring private patient information to portable media devices. The use of encrypted USB devices is recommended.



CAUTION:

C038

In case of a security event resulting in an workstation configuration files modification, the following alert message will appear on the workstation screen:

“Validation of workstation configuration files failed. Shutdown and run validation utility.”

Contact the local IT and InSightec service representative and do not proceed using the system until the issue is resolved.

Every Treatment export includes system login audit logs and Anti-Virus event logs.

- Login audit logs to the WS and the CPC can be found in a windows event viewer called ‘WsSecurity.evt’ and ‘CpcSecurity.evt’.
- Anti-Virus event logs can be found in text files called ‘OnAccessScanLog.txt’, ‘OndDemandScanLog.txt’ and ‘AccessProtectionLog.txt’.



NOTE:

N094

It is strongly recommended that local IT personnel evaluate periodically the system login audit logs and Anti-Virus event logs of treatment exports and estimate if there is any suspicion of cyber security events.



CAUTION:

C039

Shut down the system and disconnect the Workstation pc from the socket upon detection of a cybersecurity vulnerability or a security incident in the Exablate device. Report on security incidents and near misses, including those involving portable information assets, to your local IT Help/Service Desk and your InSightec representative



WARNING:

W105

Cybersecurity and software updates should only be implemented by authorized InSightec technicians/personnel.

Users should not accept or implement any updates on the Workstation or CPC (See section **Safety Instructions**).

For security and compliance reasons, The Exablate 4000 workstation is not equipped with wireless capabilities.



CAUTION:

C040

It is forbidden to connect wireless adapters such as Wi-fi or Bluetooth adapters to the Exablate 4000 workstation pc.

13.2.2. Cyber security controls & detection capabilities

- Firewall – All devices (Host, WS & CPC) are protected by windows firewall.
 - Detection capabilities: The system will block any unapproved protocol login attempt without notifying the users and log it to “Windows Firewall event viewer log”. All activities are logged in the windows defender event logs – See Section **13.2.1, Overview** for obtention of this log.
- Anti-Virus – All devices (Host, WS & CPC) are protected by windows defender antivirus with real time protection enabled, virus & threat protection updates are done periodically as part of the system maintenance.
 - Detection capabilities: All activities are logged in the windows defender event logs– See section **13.2.1, Overview** for obtention of this log.
- Whitelist protection - All devices (Host, WS & CPC) are protected by windows defender application control. WDAC provides a whitelist protection mechanism by allowing only trusted applications to run on the system.
 - Detection capabilities: In case of execution, an un-approved application system will notify the user with a notification.
- Unified Write Filter (UWF) - Protects the system partitions against unplanned and un-approved changes to the operating system partition, it enables the system to boot to a permanent state. This feature does not require maintenance or updates.
- User’s Access Control - The Exablate system users access control has a Layered authorization model.

13.3. Exablate System Minimum Network Requirements and Security Configurations



NOTE

N106

The following described communications ports are located on the back of the user’s console and are intended for use only by authorized InSightec technicians/personnel.

- 1 Parallel port – Equipment rack interface
- 1 Com (RS232) port – Controls the front LEDs
- USB ports – Intended for the Keyboard & Mouse
- Ethernet port 1 – Connected to Hospital Lan
- Ethernet port 2 – Connected to internal FUS devices (Equipment room)
- Ethernet port 3 (Optional - blocked by default) – Intended for internal InSightec maintenance.

Minimum Requirement	Host	WS	CPC	Exablate LAN Switch	Customer Firewall	Customer Network Switch
LAN						
LAN network link speed	2.5Gbps	1Gbps	1Gbps	100/1000Mbps	100/1000Mbps	100/1000 Mbps
LAN Latency	N/A	< 1Ms	< 1Ms	< 1Ms		< 1Ms
Network Switch	N/A	N/A	N/A	Layer 2 LAN Switch Min 4 Ethernet 100/1000Mbps ports	N/A	N/A
WAN						
WAN network link speed	1GPS	N/A	N/A	N/A	100/1000Mbps	100/1000 Mbps
WAN bandwidth	N/A	N/A	N/A	N/A	Minimum 15Mbps	N/A
WAN Latency	N/A	N/A	N/A	N/A	< 400Ms	N/A

TCP/UDP						
Open TCP/IP ports	N/A	All (LAN)	All (LAN)	N/A	Terminal services: TCP 3389 (RDP) VNC ports: TCP 5900 Goverlan: 443 File Transfer: TCP 22 (SSH)	N/A
IP Address	<ul style="list-style-type: none"> Dynamic address (Hospital) Static IP address (internal) 	1 Static IP address	1 Static IP address	N/A	N/A	N/A
Encryption						
Site to Site Encryption	N/A	N/A	N/A	N/A	Encryption domain: IKEv1 Diffie-Hellman Group5 No PFS IKE security associations 1440 minutes Renegotiate IPsec security associations every 3600 seconds Phase 1: AES-256/SHA 256 Phase 2: AES-256/SHA 256	N/A
Fiber						
Cabling	Minimum IEEE cat 5e					

This page is intentionally left blank for double-sided printing.

A. MANUAL DRAIN KIT USE INSTRUCTIONS



NOTE:

N099

Follow the Manual Drain Procedure when the water system is offline. The manual drain procedure takes considerably longer than draining the water nominally. In case of immediate emergency, release the patient from the patient interface without draining.

The Transducer Drain Kit includes:

- 12-liter pouch
- Silicone tube with fittings

Manual Drain Procedure:

1. Disconnect blue water fitting below Transducer and fasten to the silicone tubing



Figure A - 1: Water fitting disconnection



Figure A - 2: (L) Water pouch and Silicone tube with fittings, ® Air release Valve opening

2. Connect other end of the silicone tube to the water pouch
3. Verify Circulation tap on top of transducer is in Fill/Drain position
4. Place water pouch below transducer; wait ~10 minutes until drain completion
5. Reconnect blue water fitting below transducer

This page is intentionally left blank for double-sided printing.

B. HARD DRIVE REPLACEMENT

B.1 Overview

The Exablate clinical software is installed on the workstation (WS) PC and the Control PC (CPC).

To support the research 'mode', both hard drives must be swapped by their corresponding research drives.

At the conclusion of any research activity, the original (clinical) hard drives must be reinserted, and a DQA procedure performed with the clinical configuration.

A cleaning procedure shall be performed before and after the DQA procedure.

To enable the release of the hard drive, a dedicated key is required.



Figure B-1: Research Hard Drive Set + Dedicated Key.

B.2 Hard Drive Replacement Steps

1. Verify that the WS PC is powered down.
2. Slide the cover door to uncover the lock (See **Figure C-2**)
3. Use a dedicated key to unlock the bay (see **Figure C-3**).
4. Use the dedicated handle to release and remove drive from bay (see **Figure C-4**).
5. Gently insert the **Research** hard drive.
6. Use the dedicated handle to mount the drive into the bay (see **Figure C-4**).
7. Rotate key to **Lock** (see **Figure C-3**).

8. Slide the cover door to cover the lock (See **Figure C-2**)
9. Store the removed hard drive properly (safe, dry location, outside of MR room).
10. Repeat Steps 1 - 6 for the CPC.
11. Store the dedicated key in a safe location.

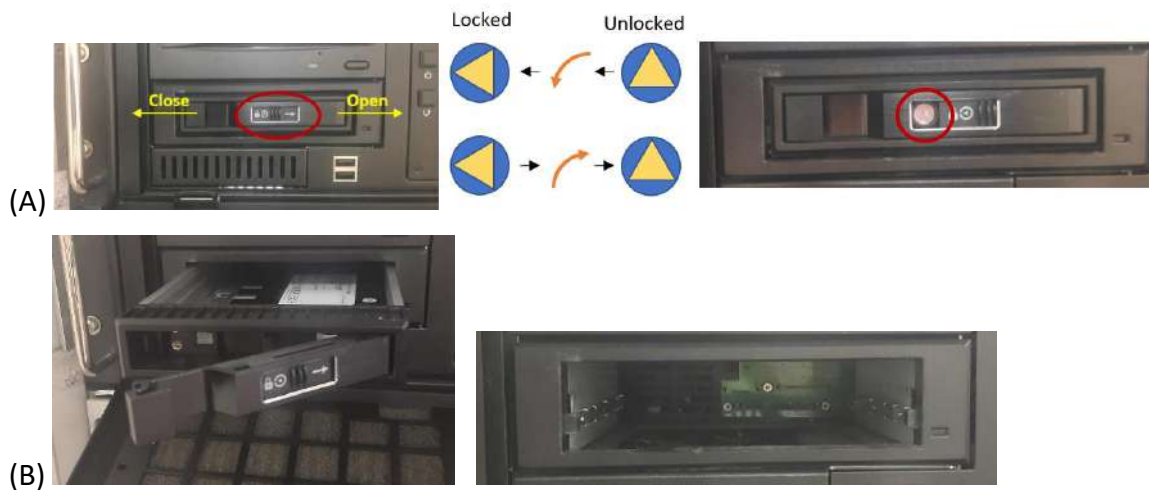

Figure B-2: Release and removal handle of Hard Drive



WARNING:

W106

- Hard drives are not MR compatible.
- Hard drives must be stored outside of the MR room.



NOTE:

N100

A mismatch mode (where one PC has the 'research' hard drive and the other has the clinical hard drive or vice versa) will result in a start-up error. In this case, the system will not be operational.

This page is intentionally left blank for double-sided printing.